

Calibrating the Parallax View: Understanding the Critical Moments of the Yugoslav Post-Socialist Turn

Dukanac, Dalia; Milinković, Marija; Bnin-Bninski, Anđelka

Veröffentlichungsversion / Published Version

Zeitschriftenartikel / journal article

Empfohlene Zitierung / Suggested Citation:

Dukanac, D., Milinković, M., & Bnin-Bninski, A. (2024). Calibrating the Parallax View: Understanding the Critical Moments of the Yugoslav Post-Socialist Turn. *Urban Planning*, 9. <https://doi.org/10.17645/up.7641>

Nutzungsbedingungen:

Dieser Text wird unter einer CC BY Lizenz (Namensnennung) zur Verfügung gestellt. Nähere Auskünfte zu den CC-Lizenzen finden Sie hier:

<https://creativecommons.org/licenses/by/4.0/deed.de>

Terms of use:

This document is made available under a CC BY Licence (Attribution). For more information see:

<https://creativecommons.org/licenses/by/4.0>

Calibrating the Parallax View: Understanding the Critical Moments of the Yugoslav Post-Socialist Turn

Dalia Dukanac , Marija Milinković , and Anđelka Bnin-Bninski 

Faculty of Architecture, University of Belgrade, Serbia

Correspondence: Dalia Dukanac (dalia.dukanac@arh.bg.ac.rs)

Submitted: 30 September 2023 **Accepted:** 16 January 2024 **Published:** 20 March 2024

Issue: This article is part of the issue “Post-Socialist Neoliberalism and the Production of Space” edited by Gabriel Schwake (Vrije Universiteit Amsterdam) and Aleksandar Staničić (TU Delft), fully open access at <https://doi.org/10.17645/up.i320>

Abstract

In this article, we seek to provide a new line of sight referring to specificities of the neoliberal turn in post-socialist societies and corresponding transformations of space. By employing the methodological approach that side-by-side explores two mutually exclusive strategies of analytical and empirical survey, we intend to tackle the question of irreducible antinomies pertinent to architectural research methodologies. Block 23 of the Central Zone of New Belgrade, designed by Branislav Karadžić, Božidar Janković, and Aleksandar Stjepanović (1968), has been widely recognised and aptly studied as one of the highlights of modern urban planning and design, conceived and realised in the period of late socialism in Belgrade (Serbia, former Yugoslavia). Featuring a notion of a “parallax gap,” we presume that the reading of Block 23 through two close yet clearly distinctive perspectives can bring a new scope of knowledge and point to the gap inscribed in the buildings themselves. The first point of view is empirical, centred on the notion of everyday life, and concerns the interpretation and use of space by its inhabitants. The second one is analytical, determined by the work of the architect and architectural theoretician, Branislav Milenković. We start from their point of contact and seek to find a shift in the diverging discursive positions producing a parallax gap. By way of architectural drawing, we explore and theorise new possibilities opened up by the actual buildings: interstitial, intermediary, transitional spaces, and spatial in-betweens. We hope to demonstrate the pursuit of both meticulously planned and dynamically conceived spaces open for the unpredictable was not only a way to respond to specific Yugoslav socio-political realities, but that it fostered the capacity of architecture to accommodate the future population and socio-economic transformations.

Keywords

Block 23; Branislav Milenković; dynamic scheme; Jugoslovenska narodna armija; New Belgrade; parallax gap; parallax view; post-socialist turn; Serbia

1. Introduction

1.1. *The Historical Grounds for the Yugoslav Neoliberal Turn*

Addressing the subject of spatial production under the neoliberal market economy in post-socialist societies, we start from the premise that the particular individual manifestations of architectural and urban practice can both reflect and subvert this globally dominant paradigm. We assume that the investigation of such critical cases can bring additional knowledge regarding the mechanisms of its transposition and disclose the moments of its suspension. To this end, the concept of “parallax” is utilised, as introduced by Japanese philosopher and literary critic Kojin Karatani and adopted later on by Slavoj Žižek, particularly in relation to architecture’s capacity to bring out the repressed antagonisms of society. The notion of parallax, that is the apparent displacement of an (observed) object due to a change of the observer’s position, was used by Karatani (2003) as a metaphor to describe the coupling of two different perspectives (parallax view) in order to provide a coherent understanding of complex relationships, pointing to a transcendental critique “capable of leading not to a third position, as such, but to the opening of transversal and transpositional movement” (Harootunian, 2004, p. 30). The methodological approach of our research is derived from Žižek’s (2010) interpretation of architectural parallax, which further aimed to foreground socio-political and ethical discourse in criticism of contemporary architecture (Nadir, 2009).

Searching for the clues that can reveal less obvious aspects of the spatial production under neoliberalism, the curious insights might be found on the margins of the ongoing process, at the very beginning of the neoliberal turn (Harvey, 2005). In societies that shared the common experience of socialism after the Second World War, it roughly coincided with the collapse of the existing economic and social system. In this respect, national states that succeeded the socialist Yugoslavia were no exception, yet the Yugoslav transition happens to be unique by involving decade-long disastrous wars. Also significantly, the shift to a market economy started already in the mid-1960s, much earlier than in other socialist states, and lasted longer, till the end of the wars and the final dissolution of the Yugoslav Federation in 2003.

Based on the massive nationalisation of land, housing stock, and means of production, the near-monopoly of the state on urban development in all socialist socio-political systems assumed systematic suppression of land and property markets (Hirt, 2013). Economic liberalisation in Yugoslavia started with the introduction of the concept of workers’ self-management in 1953 which brought a new decentralised model of housing provision and induced cultural and economic modernisation through the concept of residential communities (Le Normand, 2014). However, the turn towards a liberalised market economy was marked by the 1963 Constitution and the following Resolution of the Federal National Assembly on the Further Development of the Housing Economy (Rezolucija Savezne Narodne Skupštine, 1965). As a result, social enterprises and construction companies started to compete to provide mass housing in the still-regulated housing market, which, likewise, opened for private housing provision through favourable housing loans (Milinković et al., 2023). The 1974 Constitution and the 1980s economic strains and inflation paved the way for the dispersion of housing production and subsequent transitional measures. After the break-up of Yugoslavia, central planning mechanisms ceased to exist and the resources including land and property were gradually privatised and distributed according to market principles (Milojević et al., 2019).

Deep structural changes in Yugoslav society that coincided with the civil war could be traced through diverse spatial transformations, both those informal (ETH Studio Basel, 2012; Sekulić, 2011) and those

undertaken by the new economic elites (Perović, 2003). More to the point, both the right to housing as a socialist-modernist paradigm and the apartment as its material manifestation became tools for navigating the changing circumstances of the post-socialist turn. This was particularly distinct in spatial practices of the previously established, but now fading symbolic elites (political, intellectual, and military; Dukanac & Blagojević, 2020). In this article, by taking an “extreme but significant case” (Lefebvre, 1992, p. 38), we would argue that the Yugoslav transition to a free market economy and its spatial consequences might be explored through the lens of the daily life of a tenant in a mass housing project commissioned by the Yugoslav Peoples’ Army (Jugoslavenska Narodna Armija [JNA]).

The JNA served as one of the key devices in the shaping of a new, multinational and multicultural federation and its core values, and hence grew into an elaborate system of garrisons with a large support network of socio-cultural, health, education, but also design and construction facilities (Nikodijević, 1992). Such intricate apparatus demanded significant state budget investments, some of which were channelled towards much-needed housing development. Against the backdrop of the Yugoslav model of workers’ self-management (as of 1953) and socially-directed housing construction (as of 1974), these housing developments resulted in numerous projects, spanning from large-scale, mass housing estates such as the Central Zone of New Belgrade (Blagojević, 2012; Jovanović, 2017; Vesković & Jovanović, 2018), to smaller urban renewal interventions during the late socialist period. However, the disintegration of Yugoslavia was swiftly followed by the rapid liquidation and socio-cultural marginalisation of the JNA, which ultimately led to the “demilitarisation” of housing production (Dukanac, 2023). In these terms, the history of construction and inhabitation of Block 23 in the Central Zone of New Belgrade may provide a glimpse into the inner mechanisms of this particular social and spatial change and bring additional arguments to the overall discussion (Figure 1).



Figure 1. Photo-collage of Block 23. Note: The first image shows the completed Block, while the following two display it during construction with a focus on building no. 6. Source: “Fotografije blokova 22 i 23” (1975).

Designed by the prominent architects of the period, Božidar Janković, Branislav Karadžić, and Aleksandar Stjepanović, Block 23 was awarded the first prize at the all-Yugoslav competition in 1968 and built between 1969 and 1975 (Dragutinović et al., 2023; Jovanović, 2019). The Block was commissioned by the Federal Secretariat of Peoples’ Defence, and the 2,342 apartments, almost entirely intended for the JNA personnel, were distributed through occupancy rights. Significant for the selection of the case study was the shift in Yugoslav—and hence JNA—housing policies and strategies during the late socialist period, which was directly reflected in the spatial framework of Block 23. This included a systemic rooftop extension of buildings nos. 5

and 6 of Block 23, which produced an entire additional floor consisting of 96 new apartment units. Such alteration of a socialist-modernist block represented one of the first among many to follow in Belgrade, authorised by the 1984 Law on Superstructures and Conversion of Common Areas into Dwellings (Zakon o nadzidivanju zgrada, 1984; Figure 2). By superimposing the analysis of this process and the fallout it sparked within the individual spatial practices of the Block 23 tenants, previously unknown elements of the complex spatial production were discovered. The 1980s anticipated the transition to an open housing market by reducing housing production and encouraging housing loans, which later on led to the privatisation of housing stock in the early 1990s, as the first transitional measure implemented in all former socialist countries (Petrović, 2004). The case of Block 23 rooftop extension is interpreted within this context, as well as in relation to the general socio-economic and political conditions of late socialism, the end of the Cold War period, and the impending disintegration of the Yugoslav Federation with the accompanying conflicts across its territory.

By featuring Karatani's concept of "parallax," we presume that the re-reading of Block 23 through two diverse yet related perspectives (parallax view) can bring a new scope of knowledge. To this end, we propose a twofold enquiry. The first point of view is empirical, centred on the conception of everyday life that concerns appropriation and use of space by its inhabitants. It is conducted through historical research and problematises the shift in spatial production and distribution during the 1980s and 1990s. The second one is analytical, defined by the work of the architect and architectural theoretician Branislav Milenković. It sheds light on the original project and reveals, as Žižek (2010, p. 244) would put it, "the gap inscribed into the 'real' building itself," interpreted hereby as a parallax space. We start from a common historical background of both historical/empirical and analytical/theoretical approaches and seek to find a shift in the diverging discursive positions (parallax gap).



Figure 2. Photo of building no. 6, Block 23 in the present moment.

Thus, following the basic premises of parallax ontology, we have focused our research on the investigation of the spatial changes within Blok 23, in relation to the socio-economic shifts that marked the transition of Yugoslav socialist self-management to capitalist market economy. The concept of parallax promises a heuristic tool capable of grasping both empirical data obtained from field observations and analytical findings derived from theoretical reasoning. Consequently, on the one hand, the problem of research is centred on the potential of the applied methodology to reveal not-so-obvious relations between historical and theoretical approaches, coupled with empirical and analytical investigations. On the other hand, we seek to disclose the capacity of one specific case to adapt to, tune with, and resist the neoliberal market tendencies, accommodating effectively the ever-changing needs of its inhabitants. In a narrower sense, this article is aimed at revealing the specific local implications and transpositions of the neoliberal paradigm. More broadly, the research intends to introduce a new methodological framework that corresponds to the complexity of the research subject and addresses the multiplicity and heterogeneity of research problems. The starting assumption is that the superimposition of two related yet clearly distinctive perspectives of architectural investigation can bring additional and unforeseen insights regarding the production of space in post-socialist times.

1.2. Twofold Methodology of Research

In regard to the first line of research, the case of Block 23 has been investigated through the combination of archive material and field research that included in-depth interviews with residents and photo and graphic documentation, conducted during 2018 and 2019. A total of 42 informal, undirected interviews (Vučinić Nešković, 2013) were conducted with the aim of understanding the intimate history of housing practices of Block 23 residents, but also the wider demographic changes that followed the processes of housing privatisation and demilitarisation. The interviews included residents of various ages and economic and professional dispositions belonging to the first and the second generation of the original tenants, as well as the new economic elite acquiring apartments in New Belgrade blocks (Nikolić, 2023). The motives, ways, and results of spatial appropriation and the differentiation of a particular socio-cultural group associating themselves to JNA (which officially ceased to exist in 1992) even to the present day were documented and further analysed.

Building on the method of undirected interviews within the architectural discourse, Till (2005, pp. 34–37) advocates storytelling as part of an alternative design methodology and proposes the open-ended interview model as a research tool that affirms spontaneity and unexpectedness as important components of the research process. Such research methodology provided the authors of this article with insight into the complex relationship between designed and lived-in spaces, or in Lefebvre's (1992) words, representation of space and spatial practices. Furthermore, it resulted in an immersive experience that develops a new point of view striving to understand the singular, lived experiences of the individual resident and urban community of the Block. As storytelling became a tool for "locating the individual in shared spaces" (Till, 2005, p. 37), we were able to document, understand, and graphically represent the everyday practices of Block 23 residents and their spatial manifestations (Figure 10). By combining architectural and ethnographic research methods, we aimed to explore the potential of architectural drawing as a tool competent to inform interdisciplinary studies (Stender, 2017). The ethnographic nature of this research approach echoes the methodologies previously engaged in architectural studies during the 1970s (the time the Block was built), the academic milieu that also emanated the grounds for our second, analytical point of view of the enquiry.

Both the academic and the housing construction context of the 1960s and 1970s Yugoslavia had made way for the emergence of various scientific and applied architecture study groups which contributed to pioneering housing standards, inventive design patterns, and experimental research methodologies. Beyond their exceptional contribution to the Yugoslav scene of urban and architectural competitions (Aleksić, 1975; Baylon, 1975), the authors of Block 23 took part in different areas of housing research and design; Stjepanović worked in academia, teaching courses in housing design, while Janković and Karadžić participated in developing housing norms and standards within prominent research group Centar za Stanovanje IMS (Centre for Housing, Institute for Testing Materials in Serbia; Badnjar-Gojnić, 2019). At the same time, the Faculty of Architecture of the University of Belgrade advanced the postgraduate study program Stanovanje (Housing). The course encouraged qualitative research exploring the subjects of everyday life, the socially sustainable future of mass housing and other humanist approaches to housing design. One of the most prominent and prolific scholars in this field, and the essential figure in the organisation of this course, was Branislav Milenković.

The specificity of Milenković's analytical work in relation to our research is contained in his study of complex, dynamic spatial relationships and exploration through drawing. His body of work is highly referential as he was an eminent figure in the Yugoslav architectural context, engaged as a practising architect, university professor, and PhD-qualified researcher. Simultaneously, he was an active member of various professional associations, institutes, and commissions, and participated in numerous discussions about design standardisation. His position was defined as trans-disciplinary: anchored in urbanism, architecture, and engineering and shaped by the evolving discussions on anthropological, sociological, and philosophical questions. Milenković referred to a few contemporaries in both international and local contexts, thus establishing an authentic and autonomous stand, not aligned to any specific political current or theoretical or philosophical movement. When reflecting on spatial relations and fundamental oppositions in spatial notions, he leaned onto Heidegger's writings but dominantly focused on Lefebvre's work, specifically on the matter of dialectics traced by Slovenian philosopher Vojan Rus (1969). The systematisation of spatial oppositions, as one of the essential points of his approach, was grounded in the structuralist reasoning of Dutch architect Aldo Van Eyck. With the imperative to inspect the relations between the various scales—from urban to architectural,—Milenković investigated the logics of cross-scale thinking found in the work of Serbian philosopher Božidar Knežević (1920) and the science of ekistics by Greek urban planner and architect Constantinos Apostolou Doxiadis (1968). Milenković's particular perspective and engagement position his architectural analysis between various professional fields and address the very essence of design research.

By distancing himself from housing policies and mass construction politics during the 1950s–1970s in Yugoslavia, including the specific case of New Belgrade development, Milenković placed problematisation at the core of his research and design approach. He identified the perils caused by the growing urgency for housing construction and chronic deficit of housing space (due to vast rural-to-urban migrations and the Second World War damage) as the need for “large numbers” which degraded architectural units and urban compositions (Milenković, 1972, p. 26). Hence, the employment of Milenković's analysis in the case of Block 23 represents a new, specific contribution to our field of work.

Instead of striving for a definitive organisation of space, Milenković foregrounded changing spatial conditions and the inhabitant's experience. In an effort to propose a comprehensive and delicate methodological apparatus for architectural design, the author built a multidisciplinary research system where

the drawing, founded on theoretical and philosophical discussions, plays the central role (Bnin-Bninski, 2018). His idea to initiate new readings and provoke debate on the problems of time, change, and movement in the design process makes his research approach relevant to present-day investigations of urban and architectural practice. In this regard, we employ the architectural drawing to explore how were the transitional (parallax) spaces, opened up by the design of Block 23, adopted and co-opted in the new historical circumstances of the 1980s and 1990s, which culminated with pauperisation and catastrophic wars in Yugoslavia, and how the corresponding adaptation reflected the prolonged and gradual shift from a planned to a free-market economy (Figure 3).

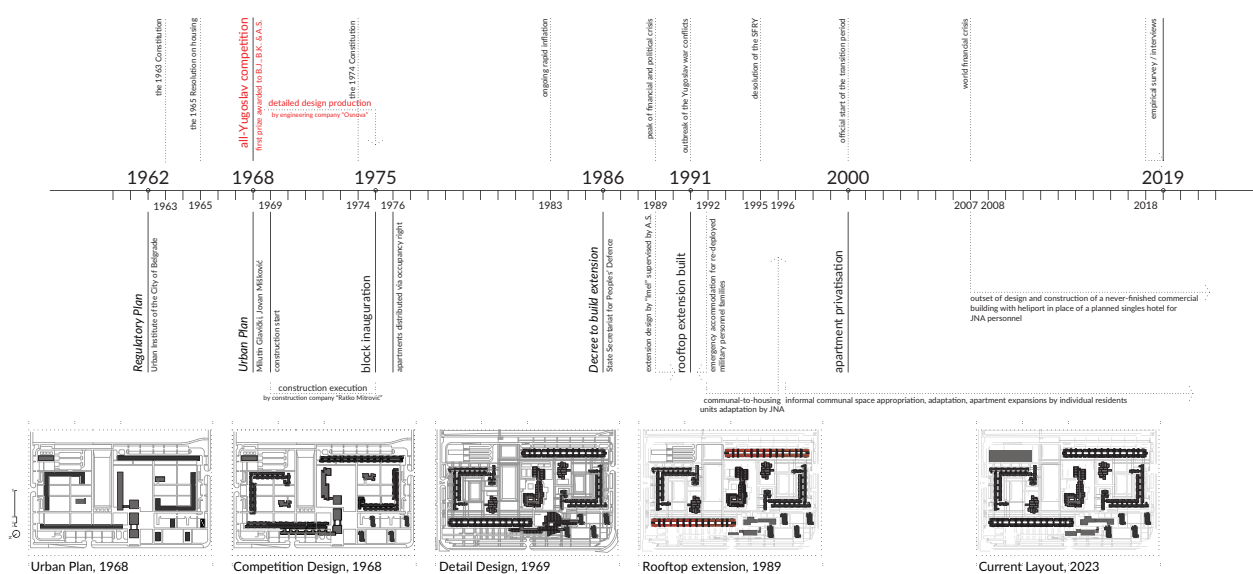

Figure 3. Timeline of Block 23 development and transformation.

2. Case Study: Investigating New Belgrade's Block 23 Through Different Urban and Architectural Scales

2.1. The Transition of the JNA to Liberal Housing Policies

The empirical survey of decades-long exploitation of Block 23 housing space spanning several contextually different periods revealed an inextricable connection between residents' spatial practices and housing design. We would argue that throughout different ideological, socio-political, and economic contexts, the apartment became a spatial mirror of professional and symbolic status, which, in the case of the JNA, was finite in time and without immediate possibility of inheritance. This distinction of the Army experienced a radical transformation during the post-socialist transition period. The previously observed stagnation of the cultural-historical model of the military (Miladinović, 2006) was overcome by the possibility of long-term and multi-generational economic capitalisation of the acquired social capital within the established Yugoslav military elite. This transposition of the capital became even more literal with the accelerated reduction of the military apparatus, whereby the military personnel often sought professional and symbolic emancipation, or experienced the devaluation of previously acquired socio-cultural resources within the service. Housing designed as part of the rooftop extension and communal units of Block 23 repurposed during the 1990s proved to be a potent subject of research on the transformation of spatial practices and the following emergence of new types of spaces.

A strategic turn in the JNA housing policies followed the general shift in housing rights and market model. As of the mid-1980s, the JNA turned to a variety of housing loans and small-scale architectural interventions replacing large-scale developments of mass housing, aiming to increase its housing stock without excessive investment. These housing strategies included, among others, the extension of the flat rooftops of socialist-modernist housing estates, and buildings nos. 5 and 6 of Block 23 represented a suitable testing ground. Although the intention to overbuild the Block was documented as early as 1986 (“Tehnički opis,” 1989), the extension project was built in 1991, coinciding with radical demographic and political changes within the Yugoslav state. The structure and functional scheme of the newly designed apartments greatly diverged from the original housing design concept and value. Furthermore, the solution to the housing deficit of military personnel was considered an urgent need in comparison to achieving the maximum cost-benefit value of the given space, which resulted in irrational gross areas of apartments with minimal or substandard individual rooms; the apartment surfaces were consumed by long corridors, landings, and vaguely defined areas. In contrast to the more flexible organisation of the original apartment units, the newly built ones, despite the skeletal steel construction, did not offer the possibility of a simple spatial-functional reorganisation (Figure 4).

In anticipation of a military conflict at the beginning of the 1990s, the redeployed JNA personnel also depended on the exploitation of the Block’s spatial resources that were not initially intended for housing. JNA’s strategies for housing displaced families included the conversion of a series of communal facilities (service, commercial, and social) into residential units. The aforementioned actions were systematic and organised, but consistently accompanied by spontaneous individual practices of appropriating (communal) space. The latter contributed to the spreading of new forms of formal and informal housing practices; for example, the practice of remodelling a flat rooftop as a means of creating additional space (and value) became widespread and is still relevant today.

2.2. The Alternative Production of Space

The main research subject presupposes the intricate superimposition of the rooftop extension and its primary building basis. Between 1989 and 1991, Block 23 underwent spatial and functional changes in order to expand the JNA’s housing stock. Coinciding with the onset of the Yugoslav Civil War and the accompanying redeployment of JNA officials from other Yugoslav republics, 96 new housing units were allocated mainly to these displaced families. We further examine how the socio-spatial strategies made possible by the socialist housing system, which arose as a result of a specific state of emergency, later mutated into a widespread housing practice of the post-socialist model of a free market economy, often debasing the wider urban space and community. It can be argued that this strategy of housing redeployed or displaced military personnel changed the image and urban fabric of New Belgrade and that these changes became permanent during the transition to an open housing market (Dukanac, 2019). This strategy led to practices that can be interpreted as an alternative production of space (Lefebvre, 1992), which, in the conditions of demilitarisation of residential and urban space, more clearly established the socio-cultural group of the members of the JNA. In the interviews conducted as part of this research, this group was particularly verbalised in the cases of displaced families of JNA personnel in relation to the rest of the residents of Block 23 and New Belgrade. This was partially due to significant changes in the original tenants following the process of privatisation and subsequent increase in housing mobility. For this reason, it became questionable whether Block 23 residents’ spatial practices can be understood through interviews

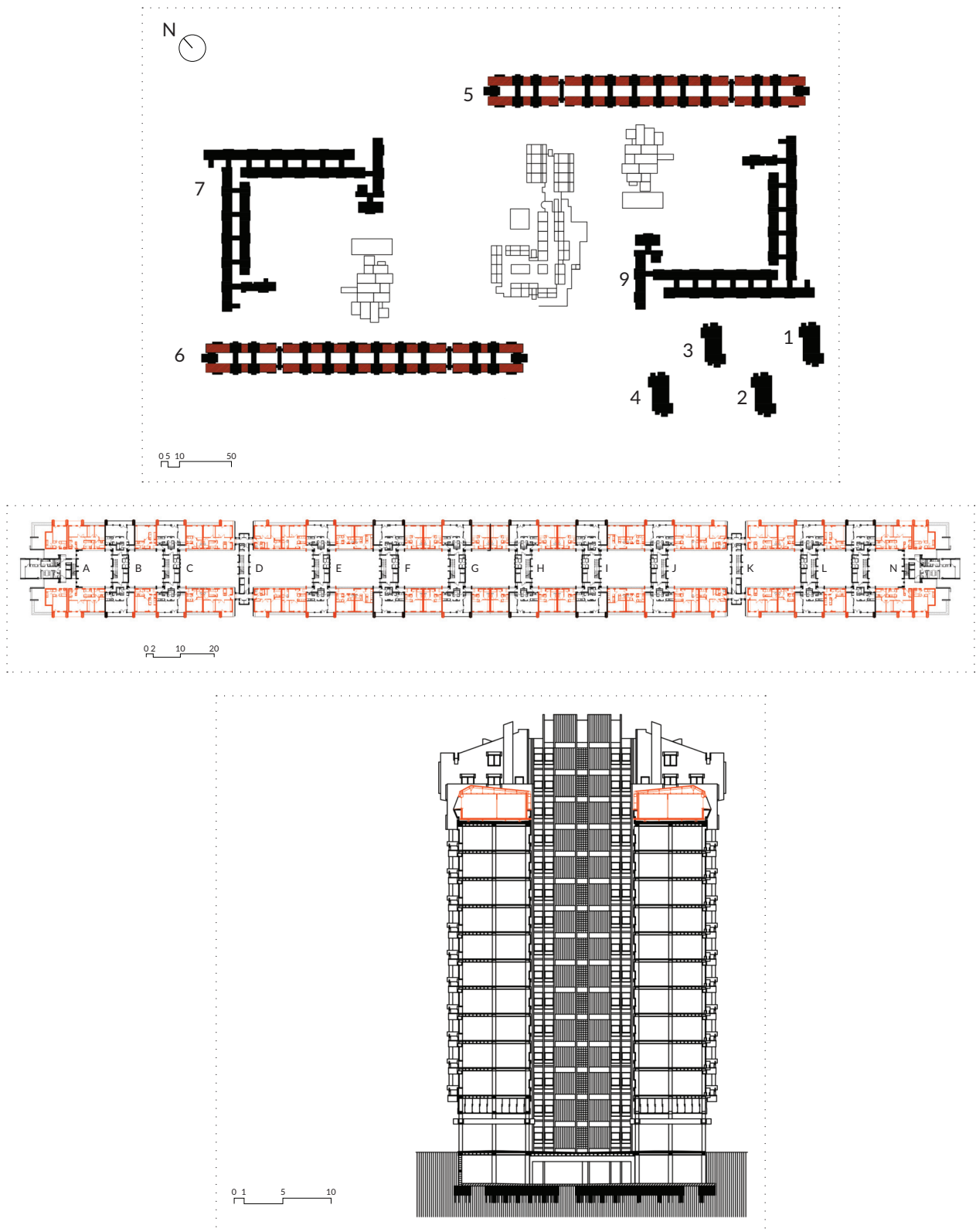

Figure 4. Rooftop extension rendered in red colour throughout various scales and plans.

based on the premise of a representative agent (Bourdieu, 2010). Conversely, ensuing the 1990s crisis, a certain collective self-image was created during the complex process of acquiring a home and the right to an apartment, under the conditions of an emergency situation—a process that caused permanent housing insecurity among the displaced families. This insecurity, on the one hand, represented an escalation of the previously formed isolation of this social group due to insufficiently developed “interest networks” that would correspond to the status acquired during the period of the dominant ideological and social role of the JNA (Miladinović, 2006); on the other hand, it progressed into marginalisation caused by the loss of the original social networks and subcultural entities, leaving this specific group of tenants in a kind of spatial and social limbo.

Buildings nos. 5 and 6 were originally designed as two-tract slabs with rhythmical stairwell interruptions creating a series of inner courtyards. The otherwise longitudinal, repetitive design of the buildings was vertically accented by atypical two-floor-level apartment units positioned in line with transverse stairwell slats. The volume design was further broken down by elaborate facade modelling enabled by the advanced concrete prefabrication industry (Jovanović, 2021) which sparked the coinage of Block 23’s colloquial design brand, the so-called “concrete baroque” (Jovanović, 2019, p. 43). Such a design approach scaled down the grand volume of the buildings and made it possible to organise residential slats as groups of four two-side-oriented apartments. Noticing the development of the typification trend, as well as the aspiration of the socially oriented housing construction towards prefabrication on the one hand and “the increasingly complex needs of the modern family for which the apartment in today’s living and working conditions acquires a much more important and complex significance,” (“Tehnički izveštaj,” 1975, pp. 1–6) on the other hand, the architects assumed the principles of designing a typical apartment unit. These principles included the disposition of the “basic core” which would enable the optimal structure of the housing stock with minor modifications, the application of a prefabricated building system, the division of the housing unit into “external and internal areas” in relation to the orientation within the two-track assembly, as well as the division into day/night and private/family zones. Such principles aimed at enriching “the possibility of a more diverse use of...space, which, with its size, position and connections in relation to...parts of the apartment, should achieve a more modern type of housing in more modest conditions” (“Tehnički izveštaj,” 1975, pp. 1–6). “More diverse use” of the housing unit was also made possible by the position of the dining area, as well as the combinatorics of movable partitions, which resulted in the performance of multiple circulation routes within the apartment (Figure 5).

The rooftop extension added from two to six new residential units per slat; the units were modest in space (27–42 m²), consisting of an entrance hall, a kitchen with a dining room, a bathroom, and one or two rooms. Although not initially intended for multi-member households, these apartments provided the necessary space for redeployed families. At the same time, the rhythmic architectural accents in the linear, repetitive structure of buildings nos. 5 and 6 were reduced. The documentation that followed the design of Block 23 revealed constant negotiations between the investor and the designer in order to achieve the highest possible value for the apartment, residential complex, and the entire block. Per contra, the dialectical relationship between assumed and real needs of inhabitants, which mostly took place spontaneously, without (preserved) documentation, informally, and sometimes illegally, was examined through field research insight into the lived experiences of tenants and their personal archives, memories, and impressions.

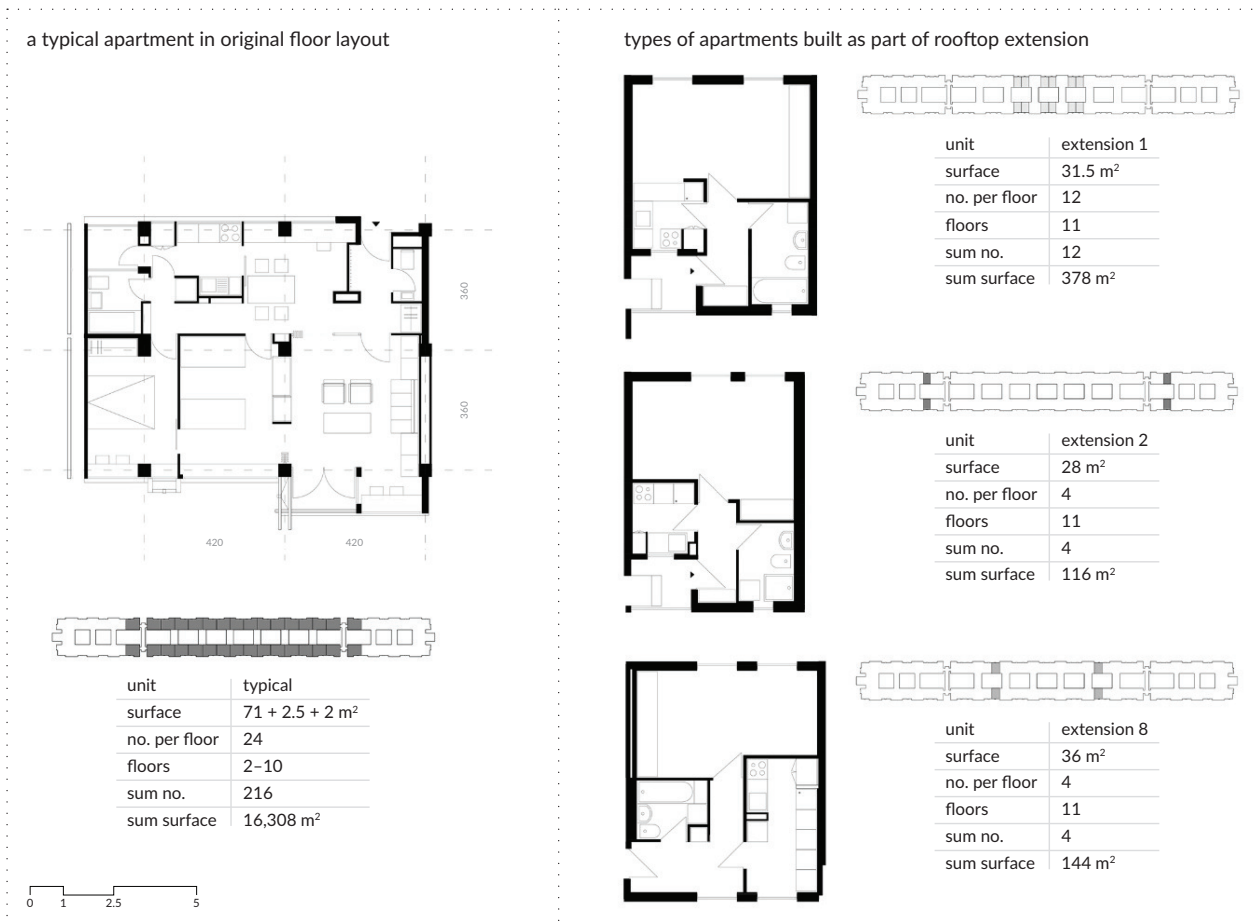

Figure 5. Typical apartment plans: Original vs. added.

In the transition from self-managed socialism and socially-directed housing construction to a free market, the apartments of Block 23 were almost all privatised, including those that were part of the strategy of housing displaced military personnel. During the precarious economic, political, and cultural period of Yugoslavia, the JNA emerged as a socio-cultural paragon which, with the support of budget funds, provided a testing ground for new models of housing construction, including the blocks of New Belgrade. Such power dynamics persisted into the period of economic stagnation, political disunity, and social turmoil resulting in very different housing practices. However, in the present moment, the individual users of the housing stock and the urban community of Block 23 participate in the dialectical process of building a new space of representation through the questioning of the inferred spatial and social patterns and practices of appropriating space (Lefebvre, 1992). These practices were documented and represented by way of three-dimensional architectural views enriched with prosaic, everyday sentiment (Figure 10). Their spatial manifestations incorporate appropriated common spaces such as communal facilities (repair shops, recreational units for pensioners, laundry and housing council rooms, and similar), passages, parts of inner courtyards, hallways, corridors, and stairwell landings, as well as rooftop terraces, much in contrast to the official JNA housing policies that produced the original urban image of the Block. To summarise the analysis of Block 23, it can be argued that, through the dialectical relationship of housing standards created by the participation of the professional and academic community and the military sector and the daily life practices of tenants, a process of “alternative production of space” was created (Lefebvre, 1992). Such production is further explored by way of analytical tools derived from Milenković’s theoretical work.

3. Parallax in Drawing Research: Re-Reading Branislav Milenković's Analytical Method

In Žižek's interpretation, the parallax gap is not just a matter of shifting perspective, but it is inscribed into the material existence of the building itself, "as if the building...bears the imprint of different and mutually exclusive perspectives" (Žižek, 2010, p. 244). In this respect, he refers to interstitial spaces, created between the skin and the content of a building, named "poche" or "spandrels," and described as any geometric configuration of space left over as a consequence of other architectural decisions. These phenomena, argues Žižek, open up the space for co-options, that is the "architectural exaptations." The distinctive guidelines for conceptualisation and analysis of parallax spaces, we would argue, can be found in the theoretical work of Branislav Milenković.

To challenge the dominant architectural production, Milenković is introducing the concept of "single-space-multi-space relationship" (*jednoprostor-višeprostor*), established upon prioritising the spatial condition "enclosed-included" over other spatial dualities (Milenković, 1972, p. 18). He describes the idea of single space as organically evolved from the common notion of "the heart of the home" (a home's central point traditionally used for family gatherings) and argues that the act of enclosing and distributing the internal space of the home results from the concept of "single space" and the particularities of its use, rather than presupposed design standards. "Each space encloses while being included in a specific way, thus all essential organic transitions from one polarity to the other—from enclosure to inclusion—are opened" (Milenković, 1972, p. 18). Such a design approach, Milenković claims, provides dynamic spatial organisation open to the unpredictability and variability of future use. Consequently, the housing design standards would not be relevant as "the difference in standards doesn't reduce the family's affiliation...the centre of the house is a place that radiates, and from which complete space, organic, rich in illusions and perspectives, an open space for deliberate and spontaneous is developed" (Milenković, 1972, p. 19). This kind of space has a nuanced scale of distribution that begins with a precise organisation stemming from the exterior, moving through fine internal partitions, and concluding with intermediate spaces or alterations in the horizontal surfaces. It is precisely in this relationship of horizontal surfaces that Milenković sees the potential for a possible departure from the demands of economy and functionality urged by the market. He further dwells on this issue by introducing the concept of "transitional space," which could connote the relationship between the internal and external atmosphere (Milenković, 1972, p. 105).

3.1. Drawing Analysis

The role of the drawing in Milenković's design analysis is essential and multifold. It correlates to a spectrum of theoretical, philosophical, and practice-based assumptions, acting as a mediator, with meticulously developed autonomy from textual content. While some drawings act as explanations or tests for his analytical hypothesis, others are introduced as design research tools open for application, interpretation, and enhancement. Considering our research framework, we point out two specific types of Milenković's drawings, devised as drawing tactics (Bnin-Bninski, 2018, p. 235): "dynamic scheme" and "dimensional tools." Both drawing tactics consider the problems of time and movement as essential elements of design practice and are thus interpreted as appropriate for a multi-scale approach in our investigation. The two drawing tactics are here employed successively as two analytical procedures on distinct spatial levels. Firstly, the "dynamic scheme" is applied as a tool for examining, testing, and understanding the dynamic relations. Secondly, the "cross-scale analytical instrument" is derived from Milenković's three-dimensional tools: limits of visual field, spheres of communication, and operational scheme. Conjointly with the "dynamic scheme,"

the newly developed analytical instrument is engaged to propose a delicate cross-scale research platform focused on the Block's inhabitants through a synchronised polygon of multiple urban and architectural scales (apartment, building, and block transitions; Figure 6).

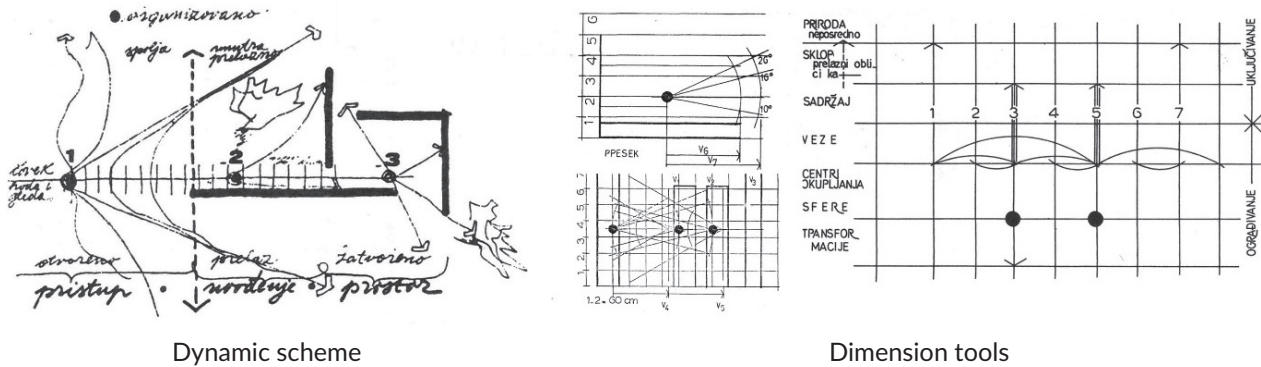

Figure 6. Dynamic scheme and dimensional tools: Limits of visual field, spheres of communication, and operational scheme. Source: Milenković (1972, p. 68).

3.1.1. Dynamic Scheme

The focus of the dynamic scheme is the concept of advent (*pojava*), which Milenković defined through the emergent values interconnecting the user's activities, spatial dynamics, and environmental influences. The dynamic scheme is rooted in the notion of transitional space as a vital concern in Milenković's analysis. It primarily employs a horizontal plan to articulate problems of temporality and movement and is rendered through various line qualities, numeration, and text. One particular drawing is highlighted here as a representative of the dynamic scheme; it is not named but described by the author:

Three key moments are in the space between the open, natural, i.e., urban environment and the enclosed, new environment: access (*pristup*), entrance (*uvod*) and the interior space—The user is in front of the form, still undecided to subdue (*osvoji*) it, while the form remains in their visual field. The second is the moment of entrance or the particular time of shift between the two environments—external and internal. The third moment is the interior space itself. (Milenković, 1972, p. 10)

The notion of the moment in Milenković's analysis can be traced to Lefebvre's theory. In his critique of everyday life, Lefebvre points out that critique is implicit in the moments of unpredictability and surprise, which he attributes to a surreal experience as opposed to reality (Lefebvre, 1991, p. 29). He argues that such a moment is an integral part of everyday life and contains pleasures that overcome its oppositions between lightness and weight, seriousness and frivolity. Regardless of the fact that Milenković formulated habitation as a place of safety and freedom, he opened his studies of the lived-in space to the criticism of everyday life in the specific Yugoslav context; this is most clearly reflected in his use of the concepts of moment and advent. To summarise, the advent is defined by the user's activities, spatial dynamics, and environmental influences, while the notion of the moment is used to capture, explore, and further elaborate the particularity and uniqueness of the advent.

In the interest of understanding the advent in the context of Block 23 in the period of the neoliberal turn, we pursue an in-depth analysis based on the employment and interpretation of Milenković's dynamic scheme.

Relying on his ideas of “transitional space” and moments of transition (implying the very nature of parallax spaces), we explore the spatial and social capacities of the Block, with a specific focus on the relation between various scales. The reference time point—the built state of the Block in 1975 (Figure 4)—enables the analysis of the implicit architectural questions in turbulent times that followed. Dwelling on the movement of an inhabitant and their relation to socio-political circumstances, we are looking back to the 1970s in order to understand why and how this housing neighbourhood exhibited certain architectural resilience. Here analysed are five specific moments of the inhabitant's transition through Milenković's lens: (M1) the Block entrance, from the highway bridge; (M2) the building entrance, through the atrium space; (M3) the hallway entrance, from the elevator to the apartment; (M4) the typical apartment entrance in buildings nos. 5 and 6; (M5) the rooftop entrance from the hallway stairs (Figure 7).

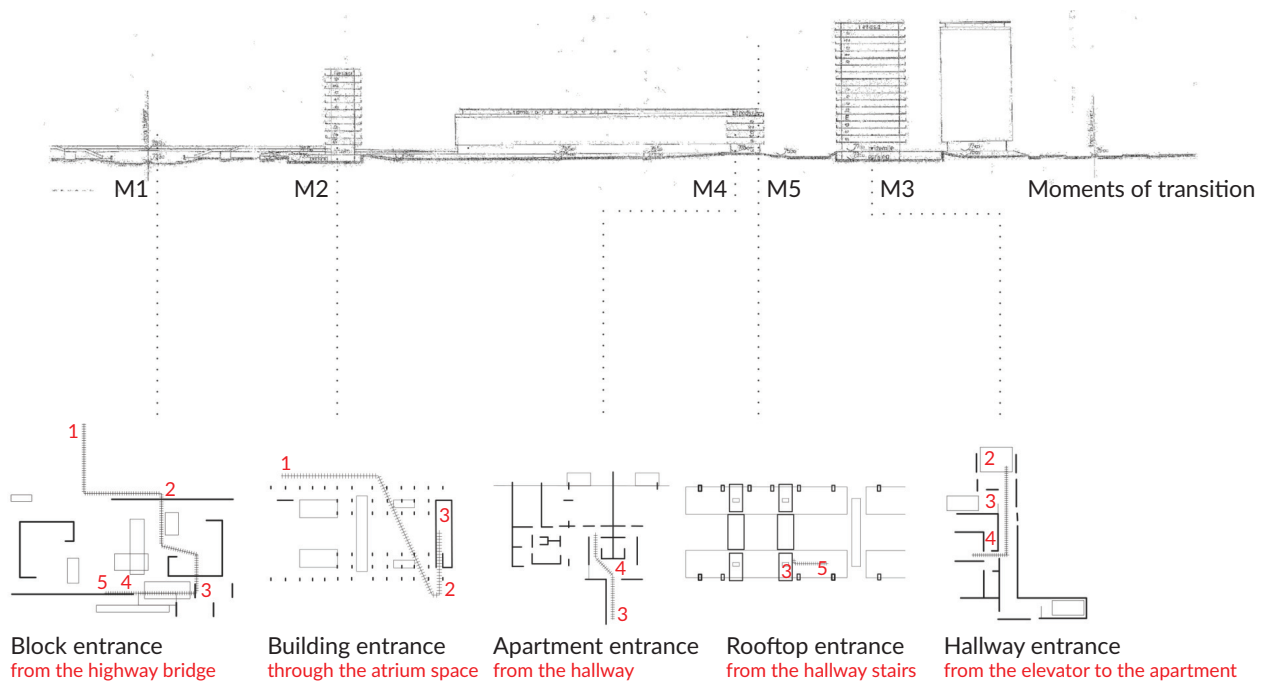

Figure 7. Dynamic schemes of transition moments identified via a cross-section of Block 23 designed as part of the urban plan from 1968. Source: “Tehnički izveštaj” (1975; intervention made by the authors).

3.2. Cross-Scale Analytical Instrument

The moments of transition explored through dynamics schemes revealed a spectrum of various in-betweens, transitional spaces, and spatial gaps. Yet this study correspondingly exposed the impossibility of cross-scale perspective. This matter is further questioned on a consecutive analytical level, centred on the inhabitant as a common and essential anchor of all examined scales. This problem was repeatedly scrutinised by Milenković, who proposed specific research tools, with an emphasis on dimensional analysis, as permanently present in the design process. He believed that the established practice of space dimensioning reduces the importance of measurement procedures to preparatory actions (Milenković, 1972, p. 59). On the contrary, the author claims that the constant verification of dimensional relations between the user's gestures and the surroundings is necessary and crucial for design practice.

With the intent to enable the cross-scale perspective (while focusing on the inter-scale relations), we directly transpose his theoretical and schematic hypothesis onto the design research via a newly proposed instrument, formulated as the theoretical-analytical drawing. In this process, the “operational scheme” is considered a cross-scale platform as it attempts to couple fluid scales of dimensioning (approaching and distancing) with the primary differentiation of space by means of enclosure and inclusion. The intention of this scheme is to consider the transformability of space and to “investigate the elasticity of space [for] all situations that cannot be fully predicted” (Milenković, 1972, p. 69).

The theoretical platform of the “operational scheme” is further elaborated with the interpretation of two other dimensional drawings: *spheres of communication* and *limits of the visual field* (Milenković, 1972, p. 68, 1985, p. 62). These drawings concern the dimensioning of the basic “spheres of spatial determination” (*sfera opredeljenja*) that generates the refined relationship between the individual and the environment. Relying on the module of 60 cm, the dimensioning of the “spheres of communication” refers to the nuance of spatial relations between intimate (15–45 cm), personal (45–75–120 cm), social (120–210–360 cm), and public sphere (360–750 cm). While the drawing regarding the spheres of communication uses a horizontal plan to develop the argument, the drawing regarding the limit of the visual field relies on a section view to demonstrate different viewing angle boundaries, whereby the total field is 120°, peripheral 90°, central 30°, and the field of maximum sharpness is 1–2°. Having established them on these three analytical tools, Milenković places the metric scales of spatial relations in the very focus of the measurement process and irrevocably relates them to the user and their perception as the only relevant criteria. Following his assumptions, we propose the theoretical-analytical drawing, i.e., the “cross-scale analytical instrument,” stressing the role and the importance of the inhabitant, their movement, and needs (Figure 8).

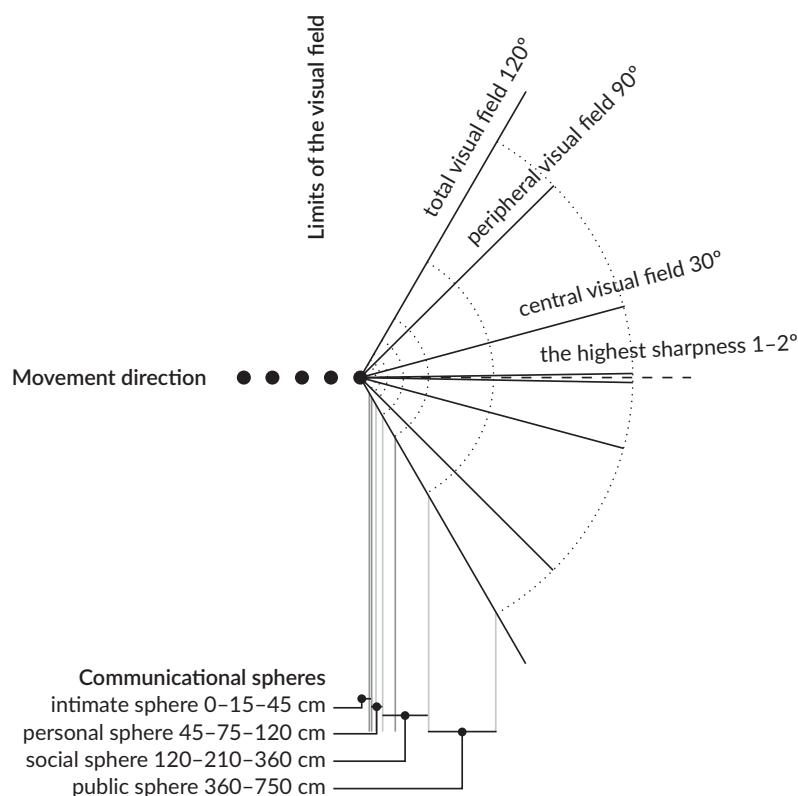

Figure 8. Cross-scale analytical instrument.

4. Discussion and Conclusions

The difficulty of combining historical and architectural critical discourse, the latter being restricted by architectural tools and procedures, was detected by Tafuri (1968/1980), approximately at the same time as the architectural project for Block 23 and Milenković's theoretical and analytical apparatus emerged. While claiming that there cannot be a true complementarity between architectural and historical critical discourse, Tafuri (1980, p. 109) remarks that "they can converse with each other but they cannot complete each other, because the two find themselves, inevitably, in competition." By assuming that this gap can be meaningful and productive, we have juxtaposed the two research methodologies, in search of the parallax effect.

The peculiarity of spatial production, appropriations, and reappropriations in the case of Block 23 indicates the high complexity of the neoliberal turn in the historical context of Yugoslavia/Serbia/Belgrade. Rather than a U-turn, the shift to a free-market economy should be seen as a gradually progressive curve, which implies it belongs to a broader chronology that began around 1965 and ended with the disintegration of Yugoslavia (1991–2003). Conceived and built at the peak of socialist growth, already fuelled by the market economy, Block 23 reflects both the virtuosity of spatial production in late socialism and contains traces of its crisis and subsequent collapse. The historical narrative informed by empirical surveys shows that the spatial changes during the 1980s and 1990s were apparently minor but substantial. In relation to socio-political background, the type and scope of spatial transformations speak of systemic appropriation and usurpation of the common spaces and the existing building infrastructure, initially supported by state institutions. Paradoxically, the mega-structures of the socialist-modernist mass housing settlement were able to absorb the side-effects of the social turn: from "the bad taste of its inhabitants" (Tafuri, 1976) to the new developments, marked by the unfinished office building at the corner of the Block, serving as a true expression of ambitions and perils of construction under the free-market economy (Figure 9; see also Figure 3).

On the other side, theoretical assay through analytical drawings discloses the intrinsic logic and spatial relations indicated by the original design. By deciphering the specific spatial constellations, initially distinguished as a parallax gap, that is "the inscription of our changing temporal experience when we approach and enter the building" (Žižek, 2010, p. 245), the analysis speaks of openness to changes and points to the type and scope of changes the design invoked. Ranging from intimate to environmental scale and from everyday life adjustments to emergency dwelling construction, the spatial transformations reflect, not only the changing needs of the inhabitants but the overall social and economic shift. The moments of transition explored through dynamic schemes revealed a spectrum of various spatial in-betweens. These interstitial spaces, argues Žižek (2010, p. 278), are "the proper place for utopian dreaming—they remind us of architecture's great politico-ethical responsibility: much more is at stake in architectural design than may at first appear."

With his newly coined term "geometrical schematism," Milenković uses terminology issued from architectural drawing to disapprove the simplification and banalisation of the (current) design process. In relation to other modes of critical practice within the broader discourse of Yugoslav architectural modernism (Milenković, 2013), his criticism of social circumstances is contained in the method itself. Finally, Milenković suggests that focusing on the problem conception, instead of the space formulation, could be a pivotal point in architectural design. From the perspective of a designer, he places the problem at the crossroads between the user's needs, client,

spatial issues, formal determinants, and general environmental conditions, while rethinking both social and climatic prerequisites. He underlines that it is not possible to reduce the housing design process to standards and dimensions prescribed by a handbook, rather that it is necessary to consider the mutability of space and its orientation to the environment to achieve particular inhabitation quality and social, economic, and environmental durability.

Both perspectives speak of lost expertise. The fact that one of the architects of the original project from 1968 has signed the 1989 project for remodelling of flat roofs only stresses the fact that the wastage was not personal, but structural: the knowledge and expertise were still present and available, but the conditions for their implementation changed fundamentally. Indeed, the pioneering housing standards, inventive design patterns and experimental research methodologies became obsolete within the pervasive landscape of the free market (see Blagojević, 2008). Analysis of the specific moments of the inhabitant's transition, supplemented by the "cross-scale analytical instrument," comprises the fragments of this critical knowledge. In the final step, we paired them up with correlative graphical simulations, informed by qualitative field research, capturing the perplexities of everyday life (Figure 10). Still avoiding the overlap of the two parallel lines of thought, we have cautiously brought them together, thus opening the space for novel investigations and new interpretative keys.



Figure 9. Photo of present-day Block 23. Note: Building no. 7 is superimposed with the unfinished office building.

The moments of the inhabitant's transition can be traced back to the dynamic schemes (Figure 7) where they were identified within the urban plan, stressing the cross-scale experience through the previously discussed topic of the entrance (M1–M5). The newly created “cross-scale analytical instrument” is applied directly to each of the five dynamic schemes. This procedure implies that multiple design research tools from Milenković's analysis were applied simultaneously with the aim of inspecting the transitional as the substance of parallax space. The study of the transition moments (from the intimate to the public sphere, from the Block to the dining room) stands in parallel to the vertical sequence of descriptive perspective drawings representing the parallax spaces in present-day situations. The detailed descriptive drawings outline the findings of the empirical survey that corresponds to the five dynamic schemes. Horizontally related, schemes and perspectives highlight the timespan of 50 years. The two lines of thought (analytical and empirical) refer to the concept of parallax view as they execute diverse methodological stands on the same question.

By utilising the parallax view to disclose the inherent logic and potential of parallax spaces, this research corresponds to its twofold objectives. In broader terms, it questions the dominant narratives on the neoliberal turn that assume a univocal transition from the welfare state, that is state-interventionist models, towards the contemporary global doctrine of laissez-faire market economy. The chosen case of Block 23 shows an exquisite complexity and a particular mode of resilience that both reflect and subvert the dominant paradigm, thus evoking the question of the great politico-ethical responsibility of architecture, as urged by Žižek. At the same time, the conducted research offers a methodological conception which expands the scope of investigative strategies able to respond to the complexity of contemporary themes and problems. By developing and crossing the diverse research tools, particularly informal undirected interviews and theoretical-analytical drawings, we aimed to sharpen the instruments of critical reading and understanding. Future research could build on both the specific methodological approach and the key findings of the article, ranging from lost and obsolete modernist expertise to the capability of certain, in this case, modern architectural heritage to absorb the mutations caused by neoliberal tendencies and the capacity of parallax spaces to anticipate, accommodate, and resist the future changes.

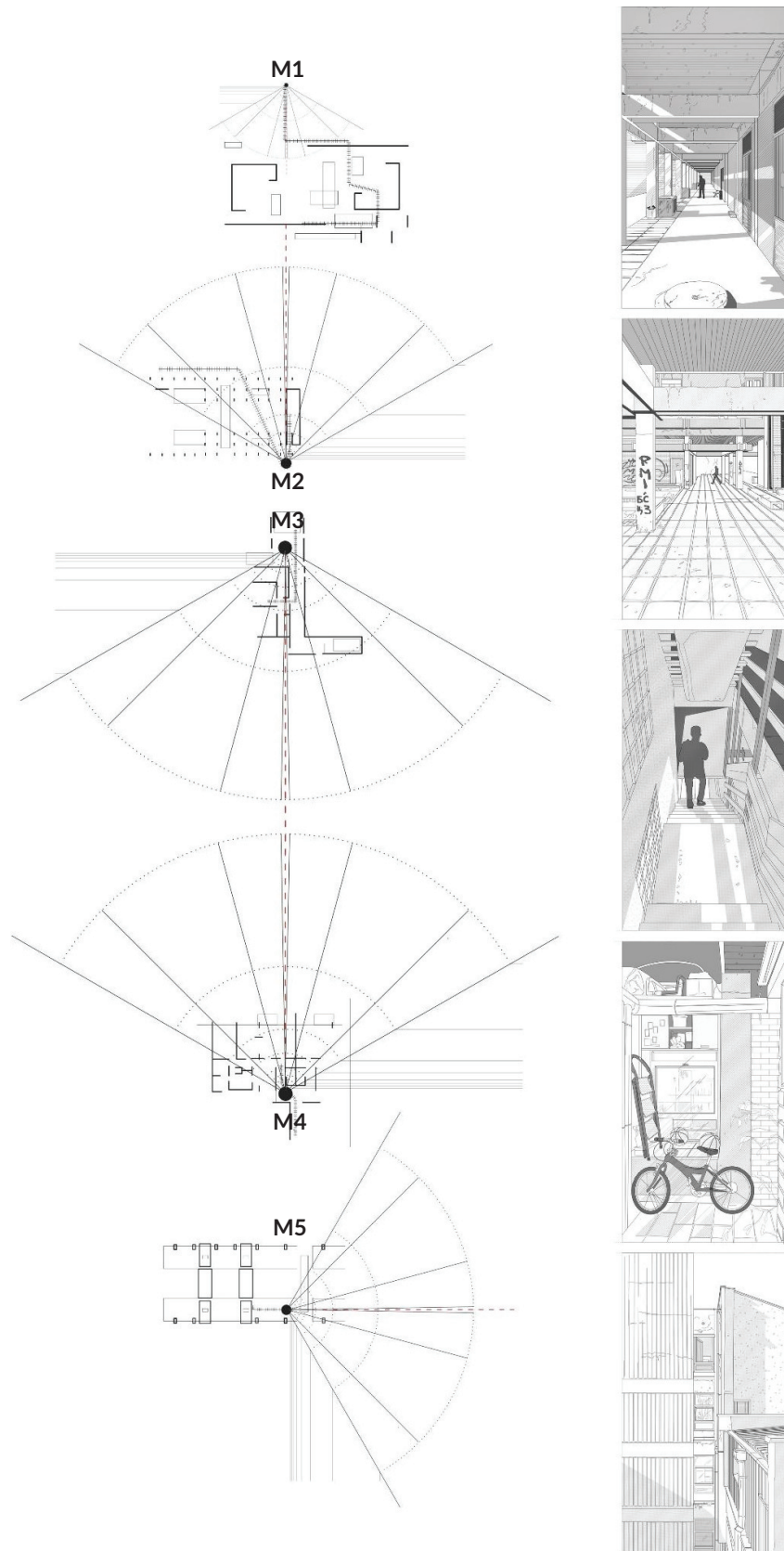

Figure 10. Juxtaposing the parallax viewpoints. Note: The detected parallax spaces of Block 23 are interconnected and showcased using two different research methodologies.

Acknowledgments

We would like to thank the editors and the reviewers for their thorough reading of the article and their valuable comments, which helped us improve the clarity and comprehensiveness of our research.

Conflict of Interests

The authors declare no conflict of interests.

References

- Aleksić, B. (1975). Konkursni stan. *Arhitektura Urbanizam*, 1975(74/77), 43–44.
- Badnjar-Gojnić, A. (2019). Opening prefabrication to participation: The Institute for Testing Materials between Switzerland, Yugoslavia and Cuba. In N. Čamprag & A. Suri (Eds.), *Three decades of post-socialist transition* (pp. 75–86). TUprints.
- Baylon, M. (1975). Stan u Beogradu. *Arhitektura Urbanizam*, 1975(74/77), 23–42.
- Blagojević, Lj. (2008). Pejzaž slobodnog tržišta. *Forum*, 53, 58–59.
- Blagojević, Lj. (2012). The residence as a decisive factor: Modern housing in the central zone of New Belgrade. *Architektúra & Urbanizmus: Journal of Architectural and Town-Planning Theory*, 46(3/4), 228–249.
- Brin-Brinski, A. (2018). *Uloga arhitektonskog crteža u dinamici podele stambenog prostora* [Unpublished doctoral dissertation]. University of Belgrade.
- Bourdieu, P. (2010). *Distinction: A social critique of the judgement of taste*. Routledge.
- Doxiadis, C. A. (1968). *Ekistics: An introduction to the science of human settlements*. Oxford University Press.
- Dragutinović, A., Quist, W., & Pottgiesser, U. (2023). Spatiality of the urban commons: Typo-morphology of the open common spaces in New Belgrade mass housing blocks. *Frontiers of Architectural Research*, 12(3), 444–457.
- Dukanac, D. (2019). From emergency accommodation to permanent transformation: The long-term impact of housing displaced army personnel in Belgrade. In A. Gola, A. Singh, & A. Singh (Eds.), *Displacement and domesticity since 1945: Refugees, migrants & expats making homes* (pp. 97–105). KU Leuven Department of Architecture.
- Dukanac, D. (2023). *Re-konceptualizacija upotrebne vrednosti stana: Tumačenje svakodnevnog života u stambenoj izgradnji za potrebe JNA* [Unpublished doctoral dissertation]. University of Belgrade.
- Dukanac, D., & Blagojević, Lj. (2020). Spaces of transition: Testing high standard housing in post-socialist Belgrade. *Planning Perspectives*, 35(6), 969–1004.
- ETH Studio Basel. (2012). *Belgrade—Formal/informal: A research on urban transformation*. Scheidegger & Spiess.
- Fotografije blokova 22 i 23. (1975). TANJUG fund (Folder 27471). Archives of Yugoslavia, Belgrade, Serbia.
- Harootunian, H. (2004). Karatani's Marxian parallax. *Radical Philosophy*, 127. <https://www.radicalphilosophy.com/article/karatani-marxian-parallax>
- Harvey, D. (2005). *A brief history of neoliberalism*. Oxford University Press.
- Hirt, S. (2013). Whatever happened to the (post)socialist city? *Cities*, 32, 529–538.
- Jovanović, J. (2017). Mass heritage of New Belgrade: Housing laboratory and so much more. *Periodica Polytechnica Architecture*, 48(2), 106–112.
- Jovanović, J. (2019). Arhitekta Aleksandar Stjepanović. Infrastruktura društva: Stanovanje i prateće funkcije, objekti dečije zaštite, školstva i visokog obrazovanja. In J. Ivanović Vojvodić, D. Jovović Prodanović, & R. Sarić (Eds.), 14. *Beogradska internacionalna nedelja arhitekture* (pp. 37–56). Beogradska Internacionalna Nedelja Arhitekture.
- Jovanović, J. (2021). Prefabricating non-alignment: The IMS Žeželj system across the decolonized world. In J. Mascarenhas-Mateus & A. P. Pires (Eds.), *History of construction cultures* (pp. 311–318). CRC Press.

- Karatani, K. (2003). *Transcritique: On Kant and Marx*. The MIT Press.
- Knežević, B. (1920). *Zakon reda u istoriji*. Geca Kon.
- Lefebvre, H. (1991). *Critique of everyday life* (Vol. 1). Verso.
- Lefebvre, H. (1992). *The production of space*. Blackwell.
- Le Normand, B. (2014). *Designing Tito's capital: Urban planning, modernism, and socialism in Belgrade*. University of Pittsburgh Press.
- Miladinović, S. (2006). Problem tumačenja rezultata istraživanja društvene (strukture i) pokretljivosti: Ideja socijalnog i kulturnog kapitala. In M. Nemanjić & I. Spasić (Eds.), *Nasleđe Pjera Burdijea—Pouke i nadahnuća* (pp. 127–134). Institut za Filozofiju i Društvenu Teoriju.
- Milenković, B. (1972). *Uvod u arhitektonsku analizu 1* (1st ed.). Građevinska Knjiga.
- Milenković, B. (1985). *Nauka o prostoru* (1st ed.). Arhitektonski Fakultet Univerziteta u Beogradu.
- Milinković, M. (2013). *Arhitektonska kritička praksa: Teorijski modeli* [Unpublished doctoral dissertation]. University of Belgrade.
- Milinković, M., Tilinger, D., Jovanović, J., Ćorović, D., Krklješ, M., Nedučin, D., Dukanac, D., & Subić, S. (2023). (Middle class) mass housing in Serbia within and beyond the shifting frames of socialist modernisation. In I. L. Rodrigues, D. Shach-Pinsly, K. Tsiambaos, & V. Korobar (Eds.), *European middle-class mass housing: Past and present of the modern community* (pp. 490–497). DINÂMIA'CET-Iscte.
- Milojević, M. P., Maruna, M., & Djordjević, A. (2019). Transition of collective land in modernistic residential settings in New Belgrade, Serbia. *Land*, 8, Article 174.
- Nadir, L. (2009). In interstitial space—Žižek on “architectural parallax.” *International Journal of Žižek Studies*, 3(3), 1–19.
- Nikodijević, D. (1992). *Vojna organizacija i kultura*. Vojnoizdavački i novinski centar; CIP.
- Nikolić, S. (2023). *Antropologija novobeogradskih blokova: Urbano stanovanje, stvaranje društvenih prostora i novi život prostornih zajedničkih dobara* [Unpublished doctoral dissertation]. University of Belgrade.
- Perović, M. (2003). *Serbian 20th century architecture: From historicism to second modernism*. Arhitektonski Fakultet Univerziteta u Beogradu.
- Petrović, M. (2004). *Socijologija stanovanja*. Institut za Sociološka Istraživanja Filozofskog Fakulteta u Beogradu.
- Rezolucija Savezne Narodne Skupštine o daljem razvoju stambene privrede. (1965). *Službeni Glasnik Republike Srbije*, 21/65.
- Rus, V. (1969). *Dijalektika čoveka i sveta*. Institut za Međunarodni Radnički Pokret.
- Sekulić, D. (2011). *Glottz Nicht so Romantisch!* Jan van Eyck Academie.
- Stender, M. (2017). Towards an architectural anthropology—What architects can learn from anthropology and vice versa. *Architectural Theory Review*, 21, 27–43.
- Tafuri, M. (1976). *Architecture and utopia. Design and capitalist development*. The MIT Press.
- Tafuri, M. (1980). *Theories and history of architecture*. Granada. (Original work published 1968).
- Tehnički izveštaj, objekat 7. (1975). [Technical report]. Archive no. 282, Box no. 62. Historical Archive of Belgrade, Belgrade, Serbia.
- Tehnički opis, opšta dokumentacija, Blok 23, objekat 5. (1989). [Technical description report]. Archive no. III-351-69/89, Box no. 6. Historical Archive of Belgrade, Belgrade, Serbia.
- Till, J. (2005). The negotiations of hope. In P. Blundell Jones, D. Petrescu, & J. Till (Eds.), *Architecture and participation* (pp. 19–40). Routledge.
- Vesković, I., & Jovanović, J. (2018). Izgradnja blokova 21, 22, 23 Centralne zone Novog Beograda i njihov značaj u okviru kulturnog nasleđa Beograda. *Nasleđe*, 19, 35–51.
- Vučinić Nešković, V. (2013). *Metodologija terenskog istraživanja u antropologiji: Od normativnog do iskustvenog*. Srpski Genealoški Centar.

Zakon o nadziđivanju zgrada i pretvaranju zajedničkih prostorija u stanove. (1984). *Službeni Glasnik Republike Srbije*, 44/84. http://demo.paragraf.rs/demo/combined/Old/t/t2006_06/t06_0171.htm
Žižek, S. (2010). *Living in the end times*. Verso.

About the Authors



Dalia Dukanac (PhD, Faculty of Architecture, University of Belgrade) graduated in 2013 and obtained her PhD in 2023. She has gained work experience both in academia and design and curatorial practices. She represented the Republic of Serbia at the 17th La Biennale di Venezia (with MuBGD) and at the 2015 Prague Quadrennial and participated at the XXI Triennale di Milano. She has published work in international journals, conference proceedings, and scholarly monographs.



Marija Milinković (MSc, PhD) is an architect and assistant professor at the Faculty of Architecture, University of Belgrade (UBFA). She graduated in 1998 from UBFA and the Moscow Institute of Architecture (MARKHI) and obtained her MSc degree in 2007 and her PhD in 2013 at UBFA. Her work has been published in international journals (*ARQ*, *Arhitektura & Urbanizmus*, *Sustainability*) and she is the author of the book *Nikola Dobrović—The Shifting Modes of Critical Practice in Architecture* (The Architecture Observer, UBFA, 2022).



Anđelka Brin-Bninski (PhD) is an architect engineer with specialisations in the theory of arts and media (University of Arts, Belgrade) and architectural philosophy (ENSA Paris—La Villette, Paris). Her expertise is drawing methodologies related to design culture and politics. She is engaged as an educator, curator, and practitioner. Her current positions are research associate at the Faculty of Architecture, University of Belgrade, and affiliated researcher at the laboratory GERPHAU in Paris. She is the vice-coordinator of the ARENA architectural research network.