

### Market innovation and competitive advantage of telecommunication companies in Kenya

Mugo, Peter; Macharia, Jimmy

Veröffentlichungsversion / Published Version

Zeitschriftenartikel / journal article

**Empfohlene Zitierung / Suggested Citation:**

Mugo, P., & Macharia, J. (2021). Market innovation and competitive advantage of telecommunication companies in Kenya. *European Journal of Management Issues*, 29(1), 37-46. <https://doi.org/10.15421/192104>

**Nutzungsbedingungen:**

Dieser Text wird unter einer CC BY Lizenz (Namensnennung) zur Verfügung gestellt. Nähere Auskünfte zu den CC-Lizenzen finden Sie hier:

<https://creativecommons.org/licenses/by/4.0/deed.de>

**Terms of use:**

This document is made available under a CC BY Licence (Attribution). For more information see:

<https://creativecommons.org/licenses/by/4.0>

UDC classification: 621.39

JEL Classification: D49, L10, L96, M37, O39

## Market innovation and competitive advantage of telecommunication companies in Kenya

P. Mugo<sup>‡</sup>,  
J. Macharia<sup>#</sup>

**Research question.** To survive, organizations must have a competitive advantage in order to stay ahead of the competition. Market innovation has remained the driving force behind most market expansions and stability in the turbulent nature of global economies. The research question for the study thus was, “do market innovations influence the competitive advantage of telecommunication companies in Kenya?”

**Design/Method/Approach.** Using the philosophy of positivism, the study adopted an explanatory research design in testing the hypothesis. The main data collection instrument was a structured questionnaire using both physical conduct and online interactions to return 247 responses from mid and top level managers in a total of 26 active telecommunications companies in Kenya. The study used both descriptive and inferential statistics using SPSS computer application to analyze the data.

**Findings.** The study findings established that innovative distribution channels significantly influenced the competitive advantage of telecommunication companies in Kenya, while advertising and promotions did not have a significant influence. This led to the conclusion that market innovation has a significant influence on the competitive advantage of telecommunication companies in Kenya.

**Practical implications.** The study recommends that telecommunication companies need to form collaborations and partnerships for establishing market distribution channels that have indicated to bring influence onto the competitive advantage of the companies. Other recommendations include a wider coverage of the East African market for the telecommunications sector. The study provides insights into new companies with interest in the region.

**Originality/Value.** From the results, marketing and promotions are not the only major contributing factors in the competitive advantage of telecommunication companies in Kenya; one must consider distribution channels too.

**Research limitations/Future Research.** The study faced limitations on visiting the field during the COVID-19 pandemic period, thus encountering entry restrictions into various premises. All protocols were observed to overcome that obstacle. Some of the telecommunications companies were facing difficulties in operations and hence could not participate.

**Paper type.** Empirical

**Keywords:** competitive advantage; market innovation; distribution channels; telecommunications industry; advertising.

<sup>‡</sup>Peter Mugo,  
Doctorate student,  
United States International University-Africa,  
Nairobi, Kenya,  
e-mail: [mugo.peter1@gmail.com](mailto:mugo.peter1@gmail.com),  
<https://orcid.org/0000-0002-0908-9545>

<sup>#</sup>Jimmy Macharia,  
PhD, Associate Professor in Information Systems,  
United States International University-Africa,  
Nairobi, Kenya,  
e-mail: [kmacharia@usiu.ac.ke](mailto:kmacharia@usiu.ac.ke),  
<https://orcid.org/0000-0002-8119-0867>

**Reference** to this paper should be made as follows:

Mugo, P., & Macharia, J. (2021). Market innovation and competitive advantage of telecommunication companies in Kenya. *European Journal of Management Issues*, 29(1), 37-46. doi:10.15421/192104.

## Ринкові інновації та конкурентні переваги телекомунікаційних компаній в Кенії

Пітер Муго<sup>‡</sup>,  
Джінні Махарія<sup>‡</sup>

<sup>‡</sup>Міжнародний університет США в Африці,  
Найроби, Кенія

**Дослідницьке питання.** Для виживання на ринку організації повинні мати конкурентну перевагу, щоб випереджати конкурентів. Ринкові інновації залишаються рушійною силою більшості ринкових розширень і стабільності в умовах турбулентності світової економіки. Ключе питання цього дослідження: «Чи впливають ринкові інновації на конкурентні переваги телекомунікаційних компаній у Кенії?».

**Дизайн/Метод/План дослідження.** Використовуючи філософію позитивізму, в дослідженні прийнято пояснювальний дослідний дизайн для перевірки гіпотези. Основний інструмент збору даних – структурована анкета, яка передбачала як особисте, так й інтерактивне спілкування. Отримано 247 відповідей від менеджерів середньої і вищої ланки в 26 діючих телекомунікаційних компаніях у Кенії. Застосовано як описову, так і логічну статистику з використанням комп'ютерної програми SPSS для аналізу даних.

**Результати дослідження.** Встановлено, що інноваційні канали збуту істотно впливають на конкурентну перевагу, в той час як реклама і рекламні акції не мають істотного впливу. Це дозволяє зробити висновок, що ринкові інновації суттєво впливають на конкурентні переваги телекомунікаційних компаній в Кенії.

**Практичне значення дослідження.** Цим дослідженням рекомендовано телекомунікаційним компаніям налагодити співпрацю і партнерство для спрощення створення каналів збуту на ринку, які, як виявилось, можуть впливати на конкурентні переваги компаній. Крім цього, рекомендовано розширити охоплення східно-африканського ринку телекомунікаційного сектора. Надано уявлення про нові компанії, які проявляють інтерес до регіону.

**Оригінальність/Цінність/Наукова новизна дослідження.** Дослідженням доведено, що маркетинг і просування – не тільки найважливіші фактори, що сприяють досягненню конкурентної переваги, але й канали поширення.

**Обмеження дослідження/Перспективи подальших досліджень.** Дослідження зіткнулося з обмеженнями щодо необхідності відвідувати місця в період пандемії COVID-19, що призвело до обмежень входу в приміщення. Всі протоколи були дотримані, щоб подолати цю перешкоду. Деякі телекомунікаційні компанії зіткнулися з труднощами в роботі і, отже, не могли брати участь.

**Тип статті.** Емпіричний.

**Ключові слова:** конкурентні переваги; ринкові інновації; канали розподілу; телекомунікаційна галузь; реклама.

## Рыночные инновации и конкурентные преимущества телекоммуникационных компаний в Кении

Питер Муго<sup>‡</sup>,  
Джинни Махария<sup>‡</sup>

<sup>‡</sup>Международный университет США в Африке,  
Найроби, Кения

**Исследовательский вопрос.** Для выживания на рынке организации должны иметь конкурентное преимущество, чтобы опережать конкурентов. Рыночные инновации остаются движущей силой большинства рыночных расширений и стабильности в условиях турбулентности мировой экономики. Ключевой вопрос данного исследования: «Влияют ли рыночные инновации на конкурентное преимущество телекоммуникационных компаний в Кении?».

**Дизайн/Метод/План исследования.** Используя философию позитивизма, в исследовании принят объяснительный исследовательский дизайн для проверки гипотезы. Основной инструмент сбора данных – структурированная анкета, в которой использовались как личные контакты, так и интерактивное общение. Получено 247 ответов от менеджеров среднего и высшего звена в 26 действующих телекоммуникационных компаниях в Кении. В исследовании использовалась как описательная, так и логическая статистика с использованием компьютерного приложения SPSS для анализа данных.

**Результаты исследования.** Установлено, что инновационные каналы сбыта существенно влияют на конкурентное преимущество, в то время как реклама и рекламные акции не имеют существенного влияния. Это привело к выводу, что рыночные инновации оказывают значительное влияние на конкурентные преимущества телекоммуникационных компаний в Кении.

**Практическое значение исследования.** Этим исследованием рекомендовано телекоммуникационным компаниям наладить сотрудничество и партнерство для упрощения создания каналов сбыта на рынке, которые, как выявилось, могут оказывать влияние на конкурентные преимущества компаний. Кроме того, рекомендовано расширить охват восточноафриканского рынка телекоммуникационного сектора. Дано представление о новых компаниях, проявляющих интерес к региону.

**Оригинальность/Ценность/Научная новизна исследования.** Исследованием доказано, что маркетинг и продвижение – не только важнейшие факторы, способствующие достижению конкурентного преимущества, но и каналы распространения.

**Ограничения исследования/Перспективы дальнейших исследований.** Ограничения исследования связаны с необходимостью посещать места в период пандемии COVID-19, что привело к ограничениям входа в помещения. Все протоколы были соблюдены, чтобы преодолеть это препятствие. Некоторые телекоммуникационные компании столкнулись с трудностями в работе и, следовательно, не могли участвовать.

**Тип статьи.** Эмпирический.

**Ключевые слова:** конкурентное преимущество; рыночные инновации; каналы сбыта; телекоммуникационная отрасль; реклама.

## 1. Introduction

Companies, irrespective of their industry affiliation, recognize competitive advantage as a superior position firms hold, relative to their rivals, throughout their internal and external firm activities (Trubnikov, 2019). Each firm establishes its own competitive niche depending on the conditions that allow it to be productive within that specific niche. Typical competitive advantages within this study's context includes marketing, research and development, distribution network, customer service, branding, and intellectual property among other activities. To maintain the competitive advantage, firms establish competitive sustainability to make it difficult for rival firms to neutralize the advantage on a specific market (Ben-Hassine, 2019).

Market innovation is an additional dimension of modernization that is thought of as the efforts and resources concentrated to new sales methods in business. From the point of view of market observers, such innovations typically remain key in a competitive advantage for organizational market sustenance (Medrano & Olarte-Pascual, 2016).

Innovations give a springboard to cost and differentiation strategies as used by the most competitive players on the market especially in the telecommunications sector. As pointed out by Sitanggang and Absah (2019), the two strategies of cost leadership and differentiation could separately lead to reduced competition and product or service sustainability, creating more capital for a market share increase. Once a competitor establishes a stronghold of any innovation, the best strategy amongst these two will test the sustainability of those innovations on the market as attested by Bayraktar et al. (2017).

## 2. Theoretical background

There is clear evidence that competitive advantage is a function of innovativeness especially in terms of market position as opposed to the traditional scientific innovativeness of products or technologies (Anning-Dorson, 2018). Due to the heavy investment required to build a market, firms strictly keep tight but strict budgets for research and development to sustain both present and future markets (Quaye & Mensah, 2019).

To sustain a high level of market innovativeness for competitive advantage requires an economy full of entrepreneurship. Major examples of countries with high entrepreneurial marketing skills include the USA, Japan, China, and Germany who have many businesses in the global market, thus maintaining a sustainable competitive advantage (Sutapa et al., 2017). Every marketing innovation might not lead to an advantage, but through the main strategies of cost leadership and differentiation, the competitive advantage becomes achievable (Anning-Dorson et al., 2018).

High-level creativity, quality services, segmentation, customization, efficient distribution channels, and meeting customers' different needs, characterize both strategies. There are three main sources of the competitive advantage for both cost leadership and differentiation strategies. These include technological innovations, skillful human resources and the organizational structure of the firm (Porter & Kramer, 2019). However, this is only possible if the firm has a strong internal system of training and development of staff, while providing motivation at the same time. This can be achieved through easy learning systems, open appraisals, human resource best practices, employment security, and employee participation that empowers innovative action (Aghion et al., 2019).

As an innovative industry emerges, performance-driven antagonism may be wild with the end goal that organizations can't bear to expect measured designs because of the aggressive and competitive nature of the industry (Muthu & Thangavelu, 2019). This study specifically chose the resource-based view

theory as it resonates with market innovations that have defined the market in the telecommunications industry. An innovative market is a form of a disruptive innovation that is easily identified with customers of a given firm, on a specific market.

### 2.1. Market innovation and competitive advantage

Market innovation has been driven by intense competition by companies trying to create a niche in the market for their products and services. According to Sun and Lee (2013), the innovations that involve both designing and technology enhancement present new products and services geared towards a specific market and this continues to sustain the universal drive for innovation.

There is strong evidence that innovations focus on the market aspect. A European study by Asimakopoulos and Whalley (2017) brought out the link between market leadership and the moderating effect of technological progress relating to mobile firm performance. Based on technological forecasting theories, the study explored the competitive advantage posed by those firms that aim to be market leaders while riding on technological innovations. The study used a 2-stage analytical design by first applying Data Envelopment Analysis (DEA) to measure performance in the telecommunication industry across Europe. In the next stage of the analysis, the study bootstrapped the DEA estimates through truncated regression to test the hypothesis. The results from the analysis leads the researchers to conclude that market leadership is a strong factor in a competitive advantage while the moderation of technological innovations can easily derail that leadership and even lead to the loss of market leadership in the European mobile telecommunication industry (Nashiruddin, 2019).

Lin, Lu and Chen (2018) carried out a study on the telecommunication market. Their focus was on the market competition and regulating reforms as they relate to technological innovations in the telecommunications industry. The study empirically examined datasets using a time series analysis from 122 countries in the period, 2010 to 2015, with the aim of establishing the relationship between market leadership, government regulation, and the moderating effect of technological innovations. Lin et al. (2018) established that technological innovations without market leadership cannot improve the performance of telecommunication firms. They cite regulation, industry market competitive advantage and the pursuit of privatization as a key in determining the competitive advantage of these firms. Berne et al. (2019) recommend the strengthening of regulatory authorities in collaboration with privatization exercises in order to protect markets from technological innovations that are costly but do not add any value to the market.

Promotional marketing in the telecommunications industry has grown to large-scale activities. The study carried out by Yeboah-Asiamah et al. (2016) focuses on the sales promotion that telecommunication companies activate in Ghana, West Africa. The study focuses on brand loyalty and the market innovation of lucky draw sales promotion (LSDP). Using a descriptive design, the study targets at a population of all lucky draw winners in Upper Accra region of Ghana using a structured questionnaire, a sample of 338 respondents via a convenient approach. Yeboah-Asiamah et al. (2016) uses structural equation modeling for analyzing the data in which the results indicate that LSDP strongly related to brand loyalty in the market. The study further applies a 4-stage process to determine the brand loyalty aspects that are influenced by LSDP. The study results indicate that market innovations like LSDP have a strong influence on the competitive advantage of a firm. Similar results are reflected in neighboring Nigeria where Rejoice et al. (2019) established that corporate imaging is a strong market competitive advantage.

Specific marketing firms affect the competitive advantage of the telecommunication industry locally. The study by *Adede et al. (2017)* focuses on electronic marketing known as e-commerce that relates to the telecommunication industry in Kenya. Anchored in the diffusion of innovations as well as the wheel of retailing theory, the study applies a descriptive design approach targeting at all telecommunications companies in Kenya. *Adede et al. (2017)* utilize a semi-structured questionnaire to collect primary data and extract secondary data from company reports and statistical abstracts. The study analyzes data through the factor analysis and regression modeling producing the results that indicate a strong relationship between e-marketing and industry performance. Compared to the studies carried out by *Njeru and Kariuki (2019)*, these results equally reveal that the competitive environment of the telecommunication industry moderates strongly between the

performance and e-commerce aspects. This implies that the telecommunications industry should be keen on the e-commerce practice while ensuring that competitiveness is well maintained. In conclusion, *Adede et al. (2017)* indicate that there is a possibility of a firm failing to perform on the market even if they have some excellent e-marketing platforms or if they do not have any competitive advantage. This is also comparable to the study by *Laban and Deya (2019)*, highlighting the strategic approach to marketing that focuses on innovation for competitive advantage in marketing of the telecommunications industry. In order to achieve the expected outcome, the current study seeks to find out the distribution channels and promotional and advertising activities in the telecommunications industry using a Likert scale to a structured questionnaire as shown in *Fig. 1*.

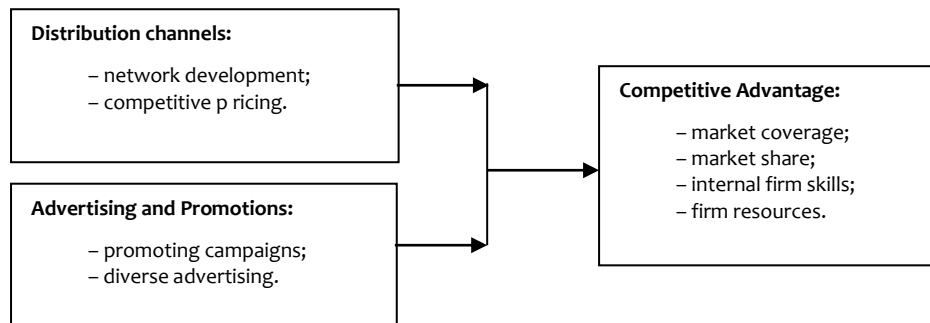

**Figure 1:** Conceptual framework of market innovation and the competitive advantage of telecommunication companies in Kenya\*

\*Source: developed by the authors.

### 3. Research question

To survive, organizations must have a competitive advantage in order to stay ahead of the competition. Market innovation has remained the driving force behind most market expansions and stability in the turbulent nature of global economies. The research question for the study thus was, “do market innovations influence the competitive advantage of telecommunication companies in Kenya?” Specific questions guiding the study were:

Q1: Do distribution channels have a significant influence on the competitive advantage of telecommunication companies in Kenya?

Q2: How do marketing promotions and advertisements influence the competitive advantage of telecommunication companies in Kenya?

### 4. Methods and data

The research methodology section covers the philosophy approach, the research design used, the population, the sample selection, the research procedure, and data analysis methods.

For the purpose of testing the study hypothesis, the variables are operationalized with various dimensions and indicators as shown in *Tab. 1*.

**Table 1:** Operationalization of marketing variables and hypothesis testing\*

Variables	Dimension	Indicator	Key Authors
<i>Independent Variables</i>			
Distribution Channels (X <sub>1</sub> )	Procedural	Distribution methods Cost of channels	<i>Asimakopoulos and Whalley (2017)</i>
Advertising & Promotions (X <sub>2</sub> )	Promotions	Customer involvement Market aggressiveness	<i>Lin et al. (2018)</i>
<i>Dependent Variable</i>			
Competitive Advantage (Y)	Cost leadership & differentiation	Market coverage Market share Internal firm skills Firm resources	<i>May and Schedelik (2019)</i>

\*Source: completed by the authors.

#### 4.1. Philosophical approach

The study adopted a positivist approach philosophy. Vouching for positivism, as a rejection of inputs of the observer or unmeasurable world aspects, the aim is to portray this philosophy in a position that holds that the goal of knowledge is simply to describe the phenomenon that is experienced (*Dougherty et al., 2019*).

#### 4.2. Research design

*Kothari (2014)* describes a research design as the conceptual structure within which the research is conducted, it makes up the outline of the data collection, measurement and analysis. This study utilizes the explanatory research design by *Cooper and Schindler (2014)*, since it is useful in establishing the relationship between variables.

### 4.3. Population and sample selection

The target population comprised all 26 telecommunication companies licensed by the Communications Authority in 2018. Based on the market share, ten companies had a market share of more than 97.5%, while the remaining ones had less than 2.5% of the telecommunications market share in Kenya. The sampling frame comprised 26 telecommunication companies targeting the management employees of these telecommunications companies. In 2019, the total number of employees in the telecommunications industry in Kenya was 8,689 (CA Report, 2019; KNBS, 2020). The total number of managers in each company varied and the company with a clear percentage of managers was Safaricom at 17.6% (Safaricom Report, 2019). The researcher worked with 30% of the total population and the sample size was calculated using the Cochran formula in two steps.

$$n_0 = \frac{Z^2 pq}{e^2} \quad (1),$$

where:

$n_0$  – Cochran's sample size;  
 $e$  – the desired level of precision (5% margin of error);  
 $p$  – the (estimated) proportion of the managers to the population is 30%;  
 $q$  – (1-p).

In our case, Cochran's sample size:

$$n_0 = \frac{1.96^2 \cdot 0.3 \cdot 0.7}{0.05^2} = 322.69$$

To obtain a higher confidence level, this equation was used to modify the sample size:

$$n = \frac{n_0}{1 + \frac{(n_0 - 1)}{N}} \quad (2),$$

where:

$n_0$  – Cochran's sample size (322.69);  
 $N$  – the population size of the telecommunication industry (8,689);  
 $n$  – the adjusted sample size.

In our case, adjusted sample size:

$$n = \frac{322.69}{1 + \frac{(322.69 - 1)}{8689}} = 311$$

### 4.4. Data collection tools

A structured questionnaire was used to collect data from the managers. The questionnaire had demographic information and two constructs representing market innovations, that is, promotions and advertising as well as distribution channels.

### 4.5. Pilot study

The study conducted a pilot survey prior to the full field visit in which 14 respondents from the companies participated and were subsequently removed from the main field study. This pilot study ensured the test of reliability and validity. The

reliability test had Cronbach's alpha of more 0.9 indicating good reliability (Cooper & Schindler, 2014). The content validity was attained by subject experts who evaluated the questionnaire and were satisfied with the content while the construct validity was attained by Average Variance Extracted (AVE) test which had of more 0.5 threshold indicating the constructs account for at least fifty per cent of the variance in the items.

A linear regression analysis model was used to test the research hypothesis. The model was appropriate in order to get the relation between dependent and independent variables.

Main hypothesis:

$H_0$ : Market innovations have no significant influence on the competitive advantage of telecommunication companies in Kenya.

The two sub-hypotheses as outlined on the conceptual framework are:

$H_{01a}$ : Distribution channels have no significant influence on the competitive advantage of telecommunication companies in Kenya.

$H_{01b}$ : Marketing promotions and advertisements have no significant influence on the competitive advantage of telecommunication companies in Kenya.

## 5. Results

Field visits to 26 telecommunications companies in Kenya yielded the data that was run through various analysis systems. The results of the findings are presented as follows: demographic information of the respondents, the descriptive statistics, the factor analysis, the correlational analysis and the regression analysis. The main aim of all the above tests was to lead to the conclusion that would eventually enable testing of the study hypothesis. Although various methods could have been used, the most viable quantitative technique used in analyzing statistical variables was regression analysis. The aim of this method generally is to explain or predict a value using known or unknown variables. The regression analysis compares and produces the results of both independent as well as dependent variables. In order to have the results for both, there is a representation given as  $R^2$ , which represents the coefficient of multiple determination. This determination is the exact proposition of the variation between the dependent variable  $Y$  and its explanation of the independent variables. Under normal circumstances, this  $R^2$  value is adjusted to explain the multiple regression results.

### 5.1. Demographic Information

A proportionate sampling yielded 247 responses, out of the 311 questionnaires sampled, from mid and top-level managers in 26 telecommunication companies in Kenya. That was 79.4% of the target respondents. The total respondents were 56% male participants and 44% female participants. This shows a 50% gender balance in the management team in the telecommunications industry.

Most managers in the telecommunications industry were aged between 24-35 years at 32%, followed by those aged 36-45 years at 26%, below 25 years old was at 15%, 46-55 year-olds was at 10% and those over 55 years were the least at 1%.

Cumulatively, more than half of the managers were aged between 25-45 years at 58%. Uniquely, 15% of the managers were below 25 years old, which is different in other industries.

### 5.2. Descriptive statistics

As indicated in Tab. 2, the independent variable has two sets of questions (the second order constructs): distribution channels, advertising and promotions. The mean of the distribution channels constructs is 3.7 which, if rounding to zero decimal places, is 4 ( $M=4$ ). This shows that the managers 'agreed' on all the questions regarding distribution channels. Further, the standard deviation (SD) value of all the questions is <1 and the skewness (Skw) is negative. The mean of the marketing promotions and advertisements constructs is 3.8 which, if rounding to zero decimal places, is 4 ( $M=4$ ). This shows the managers 'agreed' on all the questions regarding marketing promotions and advertisements.

Further, the standard deviation (SD) value of all the questions is <1 and the skewness (Skw) is negative. This shows a high level of consensus among the respondents on the level of agreement regarding the 'marketing promotions and advertisements' constructs.

**Table 2:** Mean and standard deviation of market innovation constructs (distribution mid and advertising MIA)\*

	N	Mean	Std. Deviation	Skewness	Std. Error of Skewness
MID	247	3.6977	0.44724	-0.487	0.155
MIA	247	3.8731	0.69915	-0.452	0.155

\*Source: calculated by the authors.

### 5.3. Inferential statistics

The main focus of inferential statistics is to cement the findings in the initial analysis using descriptive statistics. This enables further insights into the analytical approach to the study findings thus necessitating inferential statistics. It also provides real predictability of the population and in particular the determination of occurrence of a phenomenon by chance or design. This study in particular heavily relies upon the inferential statistics since the nature of innovation plays a big role in the basic design of destructive changes.

**Table 4:** Correlation between market innovation and competitive advantage\*

	Distribution channels	Advertising and promotions	Competitive advantage
Distribution channels	Pearson Correlation	1	
	Sig. (2-tailed)		
	N	247	
Advertising and promotions	Pearson Correlation	0.164**	1
	Sig. (2-tailed)	0.010	
	N	247	247
Competitive advantage	Pearson Correlation	0.236**	1
	Sig. (2-tailed)	0.000	0.075
	N	247	247

\*Source: calculated by the authors.

\*\*Note: correlation is significant at the 0.01 level (2-tailed).

### 5.6. Heteroscedasticity test of market innovation and competitive advantage

As indicated in Fig. 2, the scatterplot output shows the spots are concentrated within a specific area forming a pattern. It shows a higher level of similarity on the distribution of market innovation as the independent variable and competitive advantage as the dependent variable hence homogenous. In the regression model, a market innovation fits to predict the competitive advantage.

### 5.4. Factor analysis on market innovation

An exploratory factor analysis (EFA) is performed using the principal component analysis. The exploratory factor analysis is performed to: extract the pattern matrix that informs the viability of constructs included in the study; identify the questions on each matrix; and determine the strength of sampling adequacy. The questions that do not apply to the matrix are dropped.

As indicated in Tab. 3, the Kaiser-Meyer-Olkin of sampling adequacy is 0.646. Bartlett's test of Sphericity is significant at  $X^2(15, N=247)=394.316, p<0.05$ . This output shows the independent variable factors are adequate for extraction since Kaiser-Meyer-Olkin measure is greater than 0.6 and Bartlett's test is significant ( $p<0.05$ ).

**Table 3:** Test of KMO and Bartlett's on market innovation\*

Kaiser-Meyer-Olkin Measure of Sampling Adequacy		0.646
Bartlett's Test of Sphericity	Approx. Chi-Square	394.316
	Df	15
	Sig.	0.000

\*Source: calculated by the authors.

### 5.5. Correlation analysis

The correlation test is conducted to test the significant relationship between market innovations as the independent variable and competitive advantage as the dependent variable. As indicated in Tab. 4, there is a statistically significant correlation between the independent variable constructs distribution channels, and advertising and promotions  $r(247)=0.164, p<0.05$ .

On the relationship between the independent variable constructs and the dependent variable, there is a significant relationship between the distribution channels and competitive advantage  $r(247)=0.236, p<0.05$ . However, there is no significant correlation between advertising and promotions and competitive advantage  $r(247)=0.114, p>0.05$ .

### 5.7. Regression Analysis

Tab. 5 shows the model summary results. The output indicates that the influence of market innovation on the competitive advantage of telecommunication companies in Kenya is statistically significant,  $R^2=0.047, F(1, 245)=13.251, p\text{-value}<0.05$ . This shows that 4.7% of the competitive advantage of telecommunication companies in Kenya is attributed to market innovation while the remaining 95.3% can be attributed to other factors not included in the study and the error term.

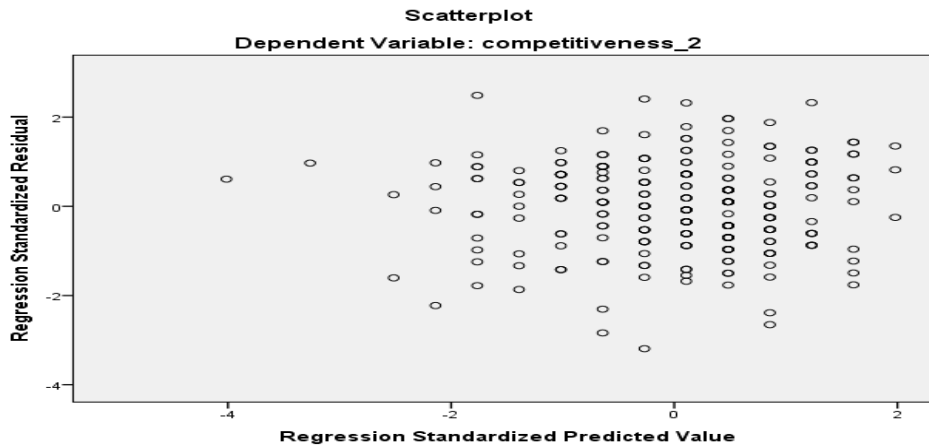

Figure 2: Heteroscedasticity of Market Innovation on Competitive Advantage\*

\*Source: built by the authors based on their own calculations.

Table 5: Model summary\* of market innovation on competitive advantage\*\*

Model	R	R Square	Adjusted R Square	Std. error of the Estimate	Change statistics				
					R square change	F change	df1	df2	Sig. F change
1	0.227***	0.051	0.047	0.41680	0.051	13.251	1	245	0.000

\*Note: Predictors: (Constant), Market innovation.

\*\*Source: calculated by the authors.

\*\*\*Note: Dependent variable: Competitive advantage.

### 5.8. Regression coefficient of market innovation on competitive advantage

As indicated in Tab. 6, the market innovation significantly predicts the competitive advantage of the telecommunications companies in Kenya ( $\beta=0.227$ ,  $t=3.640$ ,  $p<0.05$ ). This specific result leads to the rejection of the null hypothesis and the acceptance of the alternative hypothesis that market innovation has a significant influence on the competitive advantage of telecommunication companies in Kenya.

The study derives the model for market innovation and competitive advantage based on a simple regression model:

$$Y = \beta_0 + \beta_1 X_i + \varepsilon \quad (3)$$

Table 6: Market innovation regression coefficient\* on competitive advantage\*\*

Model		Unstandardized Coefficients		Standardized Coefficients	T	Sig.
		B	Std. Error	Beta		
1	(Constant)***	2.644	0.228		11.614	0.000
	Market innovation***	0.217	0.060	0.227	3.640	0.000

\*Note: Dependent variable: Competitive advantage.

\*\*Source: calculated by the authors.

\*\*\*Note: Predictors: (Constant), Market innovation.

The qualitative themes that emerge from the study are teamwork and marketing strategy. In teamwork, the key aspects are creativity, awareness of market forces, increase in a customer base, strong market skills, expansion of a marketing team, good leadership on the marketing team, use of a special marketing team and market positioning.

As for the strategy used, the aspects listed are: adequate marketing adoption, synergies in the industry, smart advertising, flexibility on the cost and marketable plans, aggressive marketing,

$H_{01a}$ : Distribution channels have no significant influence on the competitive advantage of telecommunication companies in Kenya.

where:

Y – competitive advantage;

$\beta_0$  – constant;

$\beta_1$  – market innovation;

$\varepsilon$  – error term.

In our case:

$$Y=2.644+0.227X+0.060$$

The model shows that the unit increase in the market innovation increases the competitive advantage of the telecommunications companies in Kenya by 0.227. The study, thus, rejects the null hypothesis and accepts the alternate hypothesis of the study that market innovation has a significant effect on the competitive advantage of telecommunication companies in Kenya.

and flexible bright marketing ideas. Other strategies include positive impact on the society, and establishing a strong brand in the industry. This indicates that companies employ various strategies to remain competitive in the market.

Main hypothesis of study:  $H_0$ : Market innovation has no significant influence on the competitive advantage of telecommunication companies in Kenya.

The two sub-hypothesis based on the two constructs of the study as outlined on the conceptual framework are:

$H_{01b}$ : Promotions and advertisements have no significant influence on the competitive advantage of the telecommunication companies in Kenya.



Tab. 7 shows the model summary of the hypothesis. The output indicates that the unit influence of distribution channels on competitive advantage is 2.7% ( $R^2=0.027$ ,  $p<0.05$ ) and the unit influence of promotions and advertisements on competitive advantage is 3.3% ( $R^2=0.033$ ,  $p<0.05$ ). In each model, the unit summary is less than 5%. The linear regression of the combined constructs to present the market innovation shows that the unit influence of market innovation on competitive advantage is 9.1% ( $R^2=0.091$ ,  $F(1, 245)=24.521$ ,  $p<0.05$ ). However, the unit of influence is less than 10%.

**Table 7:** Model Summary of Independent Variable on Competitive Advantage\*

	Distribution Channels	Advertising & Promotions	Competitive Advantage
R	0.164	0.182	0.156 <sup>c</sup>
R Square	0.027	0.033	0.024
Adjusted R Square	0.023	0.029	0.02
Std. Error of the Estimate	0.42215	0.42079	0.42265
R Square Change	0.027	0.033	0.024
F Change	6.743	8.381	6.146
df1	1	1	1
df2	245	245	245
Sig. F Change	0.01	0.004	0.014

\*Source: calculated by the authors.

## 6. Discussion

The key research question produces the results that reject the hypothesis  $H_0$ : market innovation has no significant influence on the competitive advantage of telecommunication companies in Kenya. It has the implication that market innovation has an influence on the competitive advantage of telecommunication companies in Kenya. The results of this study are also in agreement with previous studies carried out by others. *Asimakopoulos and Whalley (2017)* found that market leadership was key to acquiring a stable competitive advantage. This is an opportunity for such a firm to have a stronghold of the market in terms of a customer base and retained branch shares. Market innovations, thus, improve the position of the firm's competitive advantage at all levels. Similarly, *Lin et al. (2018)* support the proposition that market innovation is a disruptive design that can ensure firms' competitive advantage. Specifically, there is an observation of a marketing innovation strategy that includes various aspects like learning orientation as well as firm entrepreneurship while observing research and development innovation strategies. In essence, this leads to marketing performance. As observed in other studies, a firm can have influence of new product development with customer responsiveness leading to marketing effectiveness and marketing advantage (*Wonyra, 2018*). The scholars also established that market performance was greater in the companies with high innovations and those firms, which aimed at understanding the strategies employed by leading firms in the market. The scholars recommended that as markets transform and grow, organizations should be able to design the strategy that will be appropriate for their market in order to maintain their competitive positions. Locally, there are scholars who also support the view that market innovations play a key role in influencing the competitive advantage of a firm. *Adede et al. (2017)* in their study conclude that development techniques and e-commerce play an important role in the market innovativeness of a firm. When the two are well developed, the innovative market will lead to the competitive advantage of the firm.

On the contrary, there are scholars whose study results are contrary to the findings of the current study. *Yeboah-Asiamah et al. (2016)* established that market innovations can only work in specific zones and that not all firms understand the best market for their products as found in the study focusing on a specific area of Ghana. This has the implication that market innovations cannot be a guarantee for a competitive advantage unless the firm

To sum up, the regression model shows that the market innovation significantly predicts the competitive advantage of telecommunication companies in Kenya ( $\beta=0.227$ ,  $t=3.640$ ,  $p<0.05$ ). It shows that a unit increase in the market innovation increases the competitive advantage of the telecommunication companies in Kenya by 0.227. From this, the null hypothesis of the study is rejected and the research concludes that market innovation has a significant influence on the competitive advantage of telecommunication companies in Kenya.

completely gets its bearings correct in the market. It also means that the market is not easy to manipulate through innovativeness due mainly to costumers' loyalty over the long term. The scholars for the Ghana study also point out in their conclusions that market innovations are only applicable to specific products and services. *Lin et al. (2018)* criticize the reliance on market innovations as temporary in measure since costumers especially in the telecommunication companies' market are very sensitive to other features including technology and the actual product that the market is offering. The scholars add that people's peculiar habits can also make it difficult for any market innovativeness to work. This implies that innovative markets will not change the perception of the consumers and hence no competitive advantage will be achieved in the short- or long-term.

In terms of theory, several scholars including *Anning-Dorson (2018)* and *Sutapa et al. (2017)* theorize that the key to any market competition by an organization in the face of innovations is not to protect itself, but to fully face the innovative changes. This is a fair practice and it requires collaborations and partnerships with a view to sharing innovations in one way or another in the face of stiff competition amongst the industry players. The key issue according to *Bansal et al. (2019)* is how this market accommodates the innovations; meaning that individual companies cannot shy away from adopting the introduced innovations.

## 7. Conclusions

General study findings indicate that the market innovation has a significant influence on the competitive advantage of the telecommunications companies in Kenya. There are cases in the telecommunications companies in Kenya where specific markets are meant for specific clients but in general, all types of markets in Kenya remain active due to the good marketing strategies employed by the dominant firms on respective markets. The low-end markets catering for low-income earners use the technological innovations to keep their low-end markets very active. Similarly, the high-end markets remain vibrant following incentives that keep their costumers happy. The study observes that both markets make specific telecommunication companies remain on top of their group and hence the intensity of maintaining the markets remains high. It is, therefore, fair to conclude that the market innovation of the telecommunication companies in Kenya maintains a strong push in retaining competitive advantage most of the time.

## 7.1. Recommendations and Implications on Policy, Limitations, Theory and Practice

As indicated in the study findings, market innovation has an influence on the competitive advantage of telecommunication companies in Kenya. From the findings, it is recommended that players in the telecommunications industry can work in cohesion to better understand the Kenyan market and thus avoid the collapse of smaller or larger firms as has happened to some. It is also suggested that there can be a partnership of firms in the market together with the government in opening up regional markets instead of each firm seeking its new market in the very competitive telecommunication companies' market in the East African region. There is also a positive suggestion that the government should continue sponsoring students especially, in the study of technology markets, to the countries that are very advanced including, the Tiger nations of Korea, Hong Kong, Taiwan, as well as both European and the competitive Indian sub-continent. The study is limited to the telecommunications industry and a deep dive in the health sector would provide new marketing innovations to curb the inefficiencies in contact tracing, quarantine management and home follow-ups for COVID-19 patients.

## 8. Funding

This study received no specific financial support.

## 9. Competing interests

The authors declare that they have no competing interests.

## References

- Adede, O. A., Kibera, F. N., & Owino, J. O. (2017). Electronic marketing practices, competitive environment and performance of telecommunications companies in Kenya. *British Journal of Marketing Studies*, 5(5), 60-67.
- Aghion, P., Bergeaud, A., Boppart, T., Klenow, P. J., & Li, H. (2019). Missing growth from creative destruction. *American Economic Review*, 109(8), 77-91. doi:10.1257/aer.20171745.
- Anning-Dorson, T. (2018). Innovation and competitive advantage creation. *International Marketing Review*, 35(4), 580-600. doi:10.1108/imr-11-2015-0262.
- Anning-Dorson, T., Hinson, R. E., & Amidu, M. (2018). Managing market innovation for competitive advantage: how external dynamics hold sway for financial services. *International Journal of Financial Services Management*, 9(1), 70-87. doi:10.1504/IJFSM.2018.10011051.
- Asimakopoulou, G., & Whalley, J. (2017). Market leadership, technological progress and relative performance in the mobile telecommunications industry. *Technological Forecasting and Social Change*, 123, 57-67. doi:10.1016/j.techfore.2017.06.021.
- Bansal, G., Anand, A., & Yadavalli, V. S. S. (2019). Predicting effective customer lifetime: an application of survival analysis for telecommunication industry. *Communications in Statistics - Theory and Methods*, 49(10), 2305-2320. doi:10.1080/03610926.2019.1570264.
- Bayraktar, C. A., Hancerliogullari, G., Cetinguc, B., & Calisir, F. (2017). Competitive strategies, innovation, and firm performance: an empirical study in a developing economy environment. *Technology Analysis & Strategic Management*, 29(1), 38-52. doi:10.1080/09537325.2016.1194973.
- Ben Hassine, H. (2019). Productivity growth and resource reallocation in France: The process of creative destruction. *Economie et Statistique*, 507(1), 115-133. doi:10.24187/ecostat.2019.507d.1979.
- Berne, M., Vialle, P., & Whalley, J. (2019). An analysis of the disruptive impact of the entry of Free Mobile into the French mobile telecommunications market. *Telecommunications Policy*, 43(3), 262-277. doi:10.1016/j.telpol.2018.07.007.
- CA Report (2019). *Annual Telecommunications Report, 4th Quarter 2019*. Government Printers, Haile Selassie Avenue, Nairobi.
- Cooper, D. R., & Schindler, P. S. (2014). *Business Research Methods* (12th ed.). New York: McGraw Hill.
- Dougherty, M. R., Slevc, L. R., & Grand, J. A. (2019). Making research evaluation more transparent: Aligning research philosophy, institutional values, and reporting. *Perspectives on Psychological Science*, 14(3), 361-375. doi:10.1177/1745691618810693.
- KNBS (2020). *Annual statistical survey report of Kenya*. Government Printer, Haile Selassie Avenue, Nairobi.
- Kothari, C. (2014) *Research methodology: Methods and techniques*. (2<sup>nd</sup> ed). New Delhi: New Age International (P) Limited, Publishers.
- Laban, O. M., & Deya, J. (2019). Strategic innovations and the performance of information communication technology firms in Nairobi Kenya. *International Journal of Academic Research in Progressive Education and Development*, 8(2), 1-24. doi:10.6007/ijarped/v8-i2/5599.
- Lin, X., Lu, T. J., & Chen, X. (2018). Technological innovation, market competition, and regulatory reform in telecommunications. *Wireless Personal Communications*, 102(2), 997-1007. doi:10.1007/s11277-017-5128-9.
- May, C., & Schedelik, M. (2019). Comparative capitalism and innovation policy: complementarities and comparative institutional advantage. *Journal of Economic Policy Reform*, 1-16. doi:10.1080/17487870.2019.1637589.
- Medrano, N., & Olarte-Pascual, C. (2016). The effects of the crisis on marketing innovation: An application for Spain. *Marketing Journal of Business & Industrial Marketing*, 31(3), 404-417. doi:10.1108/JBIM-02-2013-0048.
- Muthu, D., & Thangavelu, I. (2019). Driving sustained competitive advantage through agility, NDP and innovation for telecommunication service providers. *International Journal of Business Competition and Growth*, 6(4), 244-272. doi:10.1504/IJBCG.2019.104072.
- Nashiruddin, M. I. (2019). Creating competitive advantage in the turbulent business environment: Lesson learned from Indonesia telecommunication industry. *Buletin Pos dan Telekomunikasi*, 17(1), 31-46.
- Njeru, K. N., & Kariuki, P. (2019). Influence of Mckinsey framework on competitive advantage of firms in the telecommunications industry in Kenya. *Journal of International Business, Innovation and Strategic Management*, 3(1), 68-81.
- Osano, H. M., & Koine, P. W. (2016). Role of foreign direct investment on technology transfer and economic growth in Kenya: a case of the energy sector. *Journal of Innovation and Entrepreneurship*, 5(1), 1-25. doi:10.1186/s13731-016-0059-3.
- Porter, M. E., & Kramer, M. R. (2019). Creating shared value. In *Managing sustainable business* (323-346). Springer, Dordrecht. doi:10.1007/978-94-024-1144-7\_16.
- Quaye, D., & Mensah, I. (2019). Marketing innovation and sustainable competitive advantage of manufacturing SMEs in Ghana. *Management Decision*, 57(7), 1535-1553. doi:10.1108/md-08-2017-0784.

- Rejoice, O. E., Stephen, O. U., & Oby, O. B. (2019). Relationship between corporate image and competitive advantage in mobile telecommunication industry in Nigeria. *European Journal of Innovative Business Management*, 3, 1-9. Retrieved 20 July 2020 from: [http://whitesscience.com/wp-content/uploads/woocomerce\\_uploads/2019/07/EJIBM\\_2019\\_1-9.pdf](http://whitesscience.com/wp-content/uploads/woocomerce_uploads/2019/07/EJIBM_2019_1-9.pdf).
- Safaricom Report (2019). *Annual Sectoral Report on Human Resources and Development of the Company*. Retrieved on 20 July 2020 from: [https://www.safaricom.co.ke/images/Downloads/Safaricom\\_Annual\\_Report\\_2019.pdf](https://www.safaricom.co.ke/images/Downloads/Safaricom_Annual_Report_2019.pdf).
- Sitanggang, C. H., & Absah, Y. (2019). The influence of innovation, cost leadership strategy and customer orientation on competitive advantage and its impact on customer satisfaction at container depot of Pt Masaji Tatanan Container Branch of Belawan. *International Journal of Research and Review*, 6(1), 34-46.
- Sun, S. L., & Lee, R. P. (2013). Enhancing Innovation through International Joint Venture Portfolios: From the Emerging Firm Perspective. *Journal of International Marketing*, 21(3), 1–21. doi:10.1509/jim.13.0016.
- Sutapa, S., Mulyana, M., & Wasitowati, W. (2017). The Role of Market Orientation, Creativity and Innovation in Creating Competitive Advantages and Creative Industry Performance. *Jurnal Dinamika Manajemen*, 8(2), 152-166. doi:10.15294/jidm.v1i1.12756.
- Trubnikov, D. (2019). The Russian Telecommunications Experience: a Positive Outcome of the Competitive Order in the Industry. *Journal of Industry, Competition and Trade*, 20(1), 35–58. doi:10.1007/s10842-019-00304-5.
- Wonyra, K. O. (2018). Impact of Telecommunications Market Liberalization on Labor Productivity in Economic Community of West African States. *Journal of Social Economics Research*, 5(2), 63–74. doi:10.18488/journal.35.2018.52.63.74.
- Yeboah-Asiamah, E., Quaye, D. M., & Nimako, S. G. (2016). The effects of lucky draw sales promotion on brand loyalty in mobile telecommunication industry. *African Journal of Economic and Management Studies*, 7(1), 109–123. doi:10.1108/ajems-09-2013-0076.



This is an open access journal and all published articles are licensed under a **Creative Commons «Attribution» 4.0**.