

### The Creolisation of London kinship: mixed African-Caribbean and white British extended families, 1950-2003

Bauer, Elaine

Veröffentlichungsversion / Published Version

Dissertation / phd thesis

**Zur Verfügung gestellt in Kooperation mit / provided in cooperation with:**

OAPEN (Open Access Publishing in European Networks)

#### Empfohlene Zitierung / Suggested Citation:

Bauer, E. (2010). *The Creolisation of London kinship: mixed African-Caribbean and white British extended families, 1950-2003*. (IMISCoE Dissertations). Amsterdam: Amsterdam Univ. Press. <https://nbn-resolving.org/urn:nbn:de:0168-ssoar-318792>

#### Nutzungsbedingungen:

Dieser Text wird unter einer CC BY-NC-ND Lizenz (Namensnennung-Nicht-kommerziell-Keine Bearbeitung) zur Verfügung gestellt. Nähere Auskünfte zu den CC-Lizenzen finden Sie hier:

<https://creativecommons.org/licenses/by-nc-nd/4.0/deed.de>

#### Terms of use:

This document is made available under a CC BY-NC-ND Licence (Attribution-Non Commercial-NoDerivatives). For more information see:

<https://creativecommons.org/licenses/by-nc-nd/4.0>

IMISCOE  
DISSERTATIONS

# The Creolisation of London Kinship

*Mixed African-Caribbean and  
White British Extended Families,  
1950-2003*

ELAINE BAUER

AMSTERDAM UNIVERSITY PRESS

## The Creolisation of London Kinship

## IMISCOE

### *International Migration, Integration and Social Cohesion in Europe*

The IMISCOE Research Network unites researchers from, at present, 27 institutes specialising in studies of international migration, integration and social cohesion in Europe. What began in 2004 as a Network of Excellence sponsored by the Sixth Framework Programme of the European Commission has become, as of April 2009, an independent self-funding endeavour. From the start, IMISCOE has promoted integrated, multidisciplinary and globally comparative research led by scholars from various branches of the economic and social sciences, the humanities and law. The Network furthers existing studies and pioneers new scholarship on migration and migrant integration. Encouraging innovative lines of inquiry key to European policymaking and governance is also a priority.

The IMISCOE-Amsterdam University Press Series makes the Network's findings and results available to researchers, policymakers and practitioners, the media and other interested stakeholders. High-quality manuscripts authored by Network members and cooperating partners are evaluated by external peer reviews and the IMISCOE Editorial Committee. The Committee comprises the following members:

Christina Boswell, School of Social and Political Science, University of Edinburgh, United Kingdom

Tiziana Caponio, Department of Political Studies, University of Turin / Forum for International and European Research on Immigration (FIERI), Turin, Italy

Michael Collyer, Sussex Centre for Migration Research (SCMR), University of Sussex, United Kingdom

Rosita Fibbi, Swiss Forum for Migration and Population Studies (SFM), University of Neuchâtel / Institute of Social Sciences, University of Lausanne, Switzerland

Albert Kraler, International Centre for Migration Policy Development (ICMPD), Vienna, Austria

Leo Lucassen, Institute of History, Leiden University, The Netherlands

Jorge Malheiros, Centre of Geographical Studies (CEG), University of Lisbon, Portugal

Marco Martiniello, National Fund for Scientific Research (FNRS), Brussels / Center for Ethnic and Migration Studies (CEDEM), University of Liège, Belgium

Patrick Simon, National Demographic Institute (INED), Paris, France

Miri Song, School of Social Policy and Sociology, University of Kent, United Kingdom

IMISCOE Policy Briefs and more information can be found at [www.imiscoe.org](http://www.imiscoe.org).

# **The Creolisation of London Kinship**

Mixed African-Caribbean and White British  
Extended Families, 1950-2003

*Elaine Bauer*

IMISCOE Dissertations

AMSTERDAM UNIVERSITY PRESS

Cover design: Studio Jan de Boer BNO, Amsterdam  
Layout: The DocWorkers, Almere

ISBN 978 90 8964 235 6  
e-ISBN 978 90 4851 252 2  
NUR 741 / 763

© Elaine Bauer / Amsterdam University Press 2010

All rights reserved. Without limiting the rights under copyright reserved above, no part of this book may be reproduced, stored in or introduced into a retrieval system, or transmitted, in any form or by any means (electronic, mechanical, photocopying, recording or otherwise) without the written permission of both the copyright owner and the author of the book.

*To Nicholas, Anthony, Tony and Paul*





## Table of contents

Acknowledgments	9
List of tables and figures	10
1 Introduction: London, the research context	11
2 Outlining and assessing studies of British kinship since the 1950s	45
3 Coming together: A case study of the Smith family	79
4 Extending the links: The agency of women and the significance of children in the creation and maintenance of kinship	109
5 Kinship histories: The significance of family history in the creation and maintenance of kinship relations	141
6 Mixed sociability and the growth of mixed African-Caribbean and white British families in London	173
7 Mixed heritage, racial prejudice and social positioning	207
8 Conclusion	245
Bibliography	255
Appendix I	269
Appendix II	271
Appendix III	275



## Acknowledgments

This research would not have been possible without the generous support of Lord Michael Young of the former Institute of Community Studies (presently The Young Foundation), the Canadian Social Science and Humanities Research Council (SSHRC) and the ORS Awards Scheme (United Kingdom Scholarships for International Research Students). To these funding bodies I express sincere thanks for giving me the opportunity to live and work in the United Kingdom.

This research would also not have been possible without the women, men and children who shared their experiences with me. To these individuals who welcomed me into their homes, allowed me to observe and participate in their lives and candidly told their stories as I probed into some of the most intimate areas of their family lives, I am above all grateful. All of them are quoted in this book under pseudonyms, in order to maintain confidentiality.

I would like to thank Jean Besson, Victoria Goddard, Sophie Day and Pat Caplan for their sustained support, helpful suggestions and advice. During the period of my research, I was also co-researching with Paul Thompson on a joint project on Jamaican Transnational Families. I would like to thank him for his seemingly tireless feedback and intellectual ideas.

Finally and very importantly, I thank my sons Nicholas and Anthony and all my family and friends in Canada for their understanding and encouragement, as I travelled 5,000 miles across the Atlantic to study and work in Britain.

## List of tables and figures

Table 1.1	The UK Population, by ethnic group, 2001	14
Table 1.2	Largest local Caribbean population in 1991	15
Table 1.3	Caribbean population in Britain, 1951-1991	26

### Appendix II

Table 1	Relationship category: Legally married and together	271
Table 2	Relationship category: Legally married and parted	272
Table 3	Relationship category: Cohabiting	272
Table 4	Relationship category: Cohabiting but parted	273
Table 5	Relationship category: Visiting relationships	273
Table 6	Relationship category: Foster family	273
Table 7	Female-headed households	274

### Appendix III

Table 1	Cross-generational transmission	275
Figure 3.1	The Smiths: Four generations	108
Figure 4.1	Gobi's family of origin	137
Figure 4.2	Headley's family of origin	137
Figure 4.3	Gobi and Headley's extended family	138
Figure 4.4	Randall's family	138
Figure 4.5	Courtney's family	138
Figure 4.6	Gobi's extended family	139
Figure 5.1	Ken's family of origin	170
Figure 5.2	Verna's family of origin	171
Figure 5.3	Verna and Ken Morgan's extended family	172

## 1 Introduction: London, the research context

Since the early stages of colonialism, people from the Caribbean have been coming to Britain and forming intimate and family relationships with people in British society. A well-known case is that of Francis Barber, a Jamaican slave, who at age seventeen in 1752 became servant to Dr. Johnson, author of the famous English dictionary. Barber, who was educated at Johnson's expense, remained with him and became his valet and secretary, as well as his main heir. Barber married an Englishwoman, they had four children and later bought a school, which he ran with his wife.<sup>1</sup> However, such cases were rare, and social relationships between African-Caribbean and white British people in Britain only started to become much more common during and after World War II. As a consequence of these social interactions, the last 50 years have evinced profound changes in social attitudes and patterns of family relationships in British society.

This research is an exploratory study of 34 mixed Anglo African-Caribbean and white British extended families in London across three to four generations from 1950 to 2003. I would like to emphasise at the outset that I am using the term 'white British' as a shorthand for a cluster of London families, some of whom are themselves migrants or children of migrants, whether from England, Wales, Scotland or Ireland, with varying cultural and social histories (see Holmes 1988; Jackson 1964). In particular, I do not intend to conceal the hostile experiences that some of these groups, above all the Irish, received from English Londoners (Dangerfield 1976; Gallagher, 1985; Solomos 2003) – even as recent as the 1950s and 1960s (Hickman & Walter 1997; Ryan 2004; Hickman et al. 2005). A more recent development (at the end of the period covered by this book), brought about partially because of the demands for identity and expression among some members of this group, is the introduction in the 2001 British census of 'Irish' as an ethnic category (see Aspinall 2009c; Hickman et al. 2005; Ryan 2004). However, no one in my sample identified as 'Irish' or 'Scottish'. The only participant in my research set who was born in Ireland acknowledges her Irish origin, but primarily identifies herself as 'British'. Thus, since the focus of this book is on 'mixed families' originating between white people, all from the British Isles, and African-Caribbean people,

all from the (also very varied) Caribbean, I have chosen to call the first group 'white British'.

The aim of the research is to understand the *processes* by which the family relationships of these 34 mixed families have evolved and continue to develop. I also traced intergenerational transmission of family values and practices over time and among family members who are constantly creating/re-inventing/negotiating alternative ways of being and conducting their families, against the background of the conditions and constraints that already exist in their families of origin as well as in the wider society. Central to understanding these processes are five main areas of inquiry. 1) In the context of mixed social interactions, what have been the experiences of mixed African-Caribbean and white British extended families among members in the wider society and among members in their own families? And how have their experiences changed over time? 2) How far have they innovated in their attitudes and sociability? 3) How have family values and practices been negotiated between generations? 4) What is the significance of women and children in making and sustaining kinship relations? 5) And how far have family members created and maintained kinship (including fictive kinship) bonds outside their nuclear and genealogical ties?

Fieldwork was conducted between June 2002 and December 2003 in various neighbourhoods across London. In a practice that is common to traditional social anthropology, I began fieldwork in a particular locality/neighbourhood in the city that was well defined in terms of boundary, with the intention of getting to know as many mixed African-Caribbean and white British families as I could possibly find in the neighbourhood, and spent my fieldwork in that locality largely observing their behaviour. After my encounter with the very first family, I became aware that this anthropologically tidy approach was not possible for this type of study. This approach might have worked for exploring households, or even for families among whom members do not marry outside of their own group, such as Bangladeshi families in East London (see Phillipson, Al-Haq, Ullah & Ogg 2000; Phillipson, Ahmed & Latimer 2003). But I soon realised that, unlike Young and Willmott's extended families in Bethnal Green (1957), the families in my study extended not only outside of their immediate locality into Greater London, but even to other countries across the Atlantic (see Bauer & Thompson 2006; Byron & Condon 2008). Furthermore, focusing on one locality might have posed a social class bias to my research. Thus, my inquiry involved families whose homes were dispersed across the greater London region.

Stories similar to the ones told here might be found in some other British cities, such as Nottingham, Manchester or Birmingham. There were also mixed African-British communities in some port cities such

as Cardiff, Liverpool and East London. In these cities, such communities were primarily based on the earlier settlement of African seamen, becoming the subject of anthropological and sociological studies by Little (1947) and Banton (1955). However, London has, by far, the largest cluster of Caribbean families in Britain, and there has been very little ethnographic research on them since the pioneering work of Patterson's *Dark Strangers* (1965).

It must be stressed from the start that these families do not constitute a representative sample of all mixed African-Caribbean and white British extended families in London. I have focused on some common themes that run through all the family narratives in the research, but there is considerable variety among the families in how these common themes and patterns are practised. Hence, in order to avoid broad over-generalisations, I have used micro studies of individual families to illustrate the diversity of family forms and models – and the connections between the family and wider cultural values – and the ability to transform customary family values. In other words, I have shown through individual family cases, how members in particular families relate to each other and organise their lives, given individual choices and the influences and constraints of others in their family and of the wider social forces. Nevertheless, I believe that as cases, in the anthropological tradition, they effectively 'illustrate aspects of social process and demonstrate certain theoretical principles' (Wallman 1984: vii). Rosser and Harris have pointed to the usefulness of the detailed study of single cases in 'opening up lines of thought and inquiry', and in 'raising the questions that need to be asked rather than in providing the answers – the most difficult problem of all research being to discover the right questions rather than the right answers' (1965: 18). Although about particular families, each different, each person's narratives raise a number of the issues that are central to the understanding of family and kinship behaviour, as well as of individual experiences in Britain, on the whole, and in London, in particular.

The effects of mixed sociability on the process of kinship among mixed African-Caribbean and white British extended families over time and across generations is the theme that served as a springboard for this book. Let me first begin by setting this context in which it arose.

### **London: The context of social mixing**

People from the Commonwealth Caribbean and their offspring are currently the second-largest minority ethnic groups in Britain behind people from the Indian sub-continent (Census April 2001, Office for National Statistics). In an analysis of the 2001 census, the Caribbean

**Table 1.1** *The UK Population, by ethnic group, April 2001*

	Total population		Minority ethnic population
	Count	%	%
White	54,153,898	91.2	n/a
Mixed Asian or Asian British	677,117	1.2	14.6
Indian	1,053,411	1.8	22.7
Pakistani	747,285	1.3	16.1
Bangladeshi	283,063	0.5	6.1
Other Asian	247,664	0.4	5.3
Black or Black British			
Black Caribbean	565,876	1.0	12.2
Black African	485,277	0.8	10.5
Black Other	97,585	0.2	2.1
Chinese	247,403	0.4	5.3
Other	230,615	0.4	5.0
All minority ethnic population	463,5296	7.9	100
All population	58,789,194	100	n/a

Source: Office for National Statistics (2003), Census April 2001

population in Great Britain totalled 565,876 (Table 1.1), representing 1 per cent of the total population (Office for National Statistics 2003 online). The largest proportion of the Black Caribbean population (61 per cent) lives in Greater London, with a further 15 per cent living in the West Midlands, and the remainder fairly evenly distributed (Commission for Racial Equality 2007 online). Both the 1991 and 2001 censuses showed that in the London boroughs of Lewisham, Lambeth, Brent and Hackney, Black Caribbeans form more than 10 per cent of the total population (Table 1.2) (Office for National Statistics: Census 2001 – Ethnicity and Religion in England and Wales). In Greater London, Black Caribbeans are the third-largest minority ethnic group behind Indians and Black Africans (Census, April 2001, Office for National Statistics).

A recent analysis of the Labour Force Survey shows that ‘Black Caribbean’ men and women display a higher rate of inter-ethnic group partnership than people from other ethnic groups. Moreover, nearly half (48 per cent) of the men and a third (34 per cent) of the women are in inter-ethnic partnership (couples married or cohabiting) and, for nearly half (49 per cent) of children with a ‘Black Caribbean’ mother or father, the other parent is white (Platt 2009). Both the 1991 and 2001 censuses reported that London has the largest proportions of people of ‘Mixed origin’, of which the majority are ‘Mixed White and Black Caribbean’ (David Owen 1996; Office for National Statistics 2003).



**Table 1.2** *Largest local Caribbean populations in 1991*

<i>Local authority district (thousands)</i>	<i>Caribbean people</i>	<i>% of local population</i>	<i>% of all Caribbeans in Great Britain</i>
Lambeth	37.4	15.3	5.5
Hackney	27.6	15.2	4.1
Lewisham	29.0	12.5	4.3
Brent	30.2	12.4	4.4
Haringey	23.5	11.6	3.5
Southwark	23.1	10.6	3.4
Newham	18.6	8.8	2.7
Waltham Forest	18.0	8.5	2.6
Wandsworth	19.5	7.7	2.9
Hammersmith and Fulham	11.4	7.7	1.7
Islington	11.4	6.9	1.7
Croydon	18.7	6.0	2.8
Birmingham	53.6	5.6	7.9
Ealing	15.1	5.5	2.2
Wolverhampton	12.1	5.0	1.8
Westminster, City of	8.5	4.9	1.3
Tower Hamlets	7.6	4.7	1.1
Enfield	11.8	4.6	1.7
Luton	7.7	4.5	1.1
Nottingham	11.6	4.4	1.7
Manchester	15.4	3.8	2.3
Merton	6.3	3.8	0.9
Kensington and Chelsea	5.0	3.6	0.7
Greenwich	7.2	3.5	1.1
Reading	4.4	3.4	0.7
Slough	3.4	3.4	0.5
Sandwell	9.4	3.2	1.4
Redbridge	7.1	3.1	1.0
Forest Heath	1.7	3.0	0.2
Harrow	5.8	2.9	0.8
Camden	4.8	2.8	0.7
Sum of above	466.9	—	68.8
Caribbean total	678.4	1.2	100.0

*Source:* 1991 Census of Population Base Statistics cited by D. Owen (2001: 72) in Goulbourne and Chamberlain

These figures provide a general statistical picture of the current landscape of London. It goes without saying that this has developed gradually, and especially over the last 50 years, with the history of Caribbean migration and settlement in Britain. Much has been written about this by historians and social scientists. However, a brief review here is necessary to set the scene for this development.

## A brief history of Caribbean and white British social relationships

The presence of Caribbean people in Britain has resulted from two main phases in migration patterns since the 1940s. The first phase began during World War II, when Britain recruited thousands of West Indians in support of the War effort. These recruits were predominantly men (but also a smaller number of women), many of them children of the professional classes in the Caribbean, who served in the armed forces in the Royal Air force or worked as technicians in Britain's war industry. While most of these servicemen and servicewomen returned to their home countries after the War ended in 1945, some remained. And because there were many more men than women, they tended to marry white British women. The early post-War experience is vividly conveyed by Sam Selvon's novel *The Lonely Londoners* (1956) and in Mike and Trevor Phillips' *Windrush* (1999). The second phase of migration was due partly to the response to labour shortages in Britain as a consequence of the post-War reconstruction programme (Peach 1968; Byron & Condon 2008: Chapters 1 and 2) and deteriorating economic conditions in the West Indies (Patterson 1965; Thomas-Hope 1998; Byron & Condon 2008: Chapters 1 and 2). Immediately after the War, due to the lack of regular passenger boat services, some migrants arrived in British ports as stowaways (*ibid.*: 45), others via New York. It was in 1948, on former German trooper the *SS Empire Windrush* that the first large group of West Indian migrants arrived in Britain (Phillips & Phillips 1999).

The majority of these migrants were again young males, semi-skilled and skilled workers from Jamaica (Deakin 1969). The scene shifted dramatically and the gender imbalance was resolved to a large degree in the 1950s, when British Rail, London Transport and the new National Health hospitals actively recruited in the West Indies for both men and women staff. Subsequently, in the next few years many of those already in Britain paid for other family members to join them. By the 1961 census, there were some 200,000 West Indians in England, already an unprecedentedly high figure. Half of them were from Jamaica and more than half lived in London. By 1971, the numbers had more than doubled, to over 500,000 (Phillips & Phillips 1999; Hiro 1971; Peach 1968, 1996).

### *Reaction to the new arrivals*

This second and large-scale arrival of West Indians brought a significantly different scale of contact between the white British population and people of different skin colour. Certainly, African slaves had been brought to Britain from the middle of the sixteenth century onwards to

serve the aristocracy and some wealthy merchants. And later, West Indian plantation owners would bring their own slaves back to Britain to care for them in their declining years back home in Britain. But in 1772, the famous judgment of Lord Mansfield – that slavery was not ‘allowed or approved by the law of England – brought an end to the importation of African slaves and servants, resulting in a gradual decline in the number of African slaves in Britain (Banton 1960: 55). Of the nearly fifteen thousand slaves in Britain at the time who were freed, some apparently remained in the service of their former owners, while others who had particular skilled trades moved to live in London (Patterson 1965: 42).

From the end of the eighteenth century onwards, another phase began of a ‘small but steady flow of coloured visitors’ (Banton 1960: 55). Some seamen settled in the dock areas of London, Cardiff, Bristol, Liverpool, Hull and North and South Shields (ibid.). London especially attracted ‘coloured students’, among whom West Indians were the second-largest group behind Indians (Patterson 1965: 43). Seamen were typically away at sea for long periods and, when ashore, lived in ‘isolated and self-segregated settlements’, with little contact with the indigenous British population. Students interacted with fellow students, teachers, landladies and minor officials, but left a little impression on the mass of the British populace (Patterson 1965: 42-44).

Thus, it wasn’t until World War II and the post-War years, when West Indian migrants arrived in Britain in large numbers, that the British public came into contact with them in any significant way. The overall reaction to the arrival of the new migrants by the host community was one of prejudice and hostility (see Banton 1955; Glass 1961; Patterson 1965; Byron & Condon 2008: Chapter 2). Beginning with the first arrival of immigrants on the *Empire Windrush* in June 1948, the *Daily Express* (21 June 1948 cited in Phillips & Phillips 1999: 53) reported:

**EMPIRE MEN FLEE NO JOBS LAND:  
500 HOPE TO START A NEW LIFE TODAY**

Five hundred unwanted people, picked up by the trooper *Empire Windrush* after it had roamed the Caribbean, Mexican Gulf, and Atlantic for 27 days are hoping for a new life. They include 430 Jamaican men. And there are 60 Polish women who wandered from Siberia via India, Australia, New Zealand and Africa to Mexico, where they embarked in the *Empire Windrush*. The Jamaicans are fleeing from a land with large unemployment. Many of them recognize the futility of their life at home.

At a political level, the arrival of these ‘unwanted people’ had indeed become a ‘shipload of worry’ for then Minister of Labour George Isaacs. According to the *Daily Express*, Isaacs felt the need to do his ‘best’ for the newcomers because they ‘are British citizens’, yet he also said he would ‘hope no encouragement will be given to others to follow them’ (*Daily Express*, Tuesday 8 June 1948 cited in Phillips & Phillips 1999: 59). At the local level, the new arrivals were often ‘reproached with the question “Why don’t you go home?”’ (Banton 1955: 18). Not only did they face housing difficulties from ‘white landladies and landlords’ who advertised notices reading ‘Sorry, no coloured’ or ‘English only’ (Patterson 1965: 187), but newspapers – even when supposedly liberal in their editorial attitude towards ‘coloured people’ – still accepted and printed ‘discriminatory housing advertisements’ (Glass 1961: 109). In her study, Glass found that even with housing advertisements void of any hint of discrimination, when members of her research team called, ‘enquiring about a room or flat on behalf of a West Indian friend... one out of every six were prepared to consider the application’ (ibid.: 60). Moreover, a few landlords or landladies asked: ‘Are your friends very coloured?’ implying that they might be willing to accept an ‘Indian but not a Negro’. (ibid.: 61). Additionally, Patterson (1965) found that in Brixton there was widespread belief that the arrival of West Indians in a street or neighbourhood caused property values to depreciate. Thus, there were many appeals made by local ratepayers seeking lower council taxes on the ground that ‘property values were being lowered by the “influx of Jamaicans”’ (ibid.: 171).

At work, however, because of Britain’s post-War labour shortage, discrimination was more often disguised. The recruitment of workers in both state and private enterprises was a question of public policy, determined by agreements between trade unions and employers’ associations and government. Therefore, ‘anti-coloured’ tags in advertisements of vacant jobs were not sanctioned in the same way as housing advertisements and, in the employment sphere, tolerance was ‘in some respects “nationalized”’ (Glass 1961: 66-76). Glass found that, on the whole, English people had an entirely different attitude to their workmates than they had with their neighbours or would-be-neighbours. While they were prepared to work with ‘coloured people’, or even under them, they might be most reluctant to accept the idea of living next to them. An English person was ‘far more likely to be aware of their dark skin at home than in the factory’. (ibid.: 67). By contrast, at a social level, West Indian men were widely stereotyped and ‘feared as a threat to White female sexuality’, while the women were regarded as ‘primitive and dirty’ (Chamberlain 2001a: 44).

In her classic study *Dark Strangers: A Study of West Indians in London*, Patterson (1965 [1963]) explained the reaction of the white British

population in Brixton to their West Indian neighbours in terms of 'an immigrant situation'. According to her, the situation in Britain at the time was not a 'colour or race situation, however much it may appear so to many colour-conscious migrants - it is an immigrant situation' (ibid.: 17). She described Britain at the time as an insular, conservative and homogeneous society where 'mild xenophobia or antipathy to outsiders would appear to be a cultural norm' (ibid.). However, she argued that this xenophobia or antipathy extended in varying degrees to all outsiders, whether 'Poles' or 'coloured people' or people from the next village or street (ibid.). (Indeed, the Irish, the Welsh and the Jews also experienced discrimination, but less so after the War, as they became more socially and economically integrated (see Benson 2005; Marwick 2003; Merriman 1993)).

Contrary to Patterson's argument, Glass (1961) – who conducted her research across London during the same period as Patterson conducted her work in Brixton – argued that the problem was one of colour.

No other recently arrived minority group has aroused emotions and controversies of the same intensity and scale. There has been far less interest, for example, in the migration of Poles to Britain during and after World War II than in the migration of West Indians, although the number of Poles settled here is very similar to that of West Indians.

The Poles, moreover, are in certain respects, of which language is only one, more alien than West Indians. But the West Indians in Britain are more noticeable than the Poles, irrespective of class differences between immigrants and natives, and between different groups of immigrants. And while it may be true that, as some people argue, the difficulties of all newcomers to Britain are alike, is also true that coloured people meet these difficulties in an accentuated form. They are not simply migrants: they are coloured migrants. A white newcomer can hide, or eventually lose, the obvious signs of his foreignness; a dark skinned man cannot wash off his colour. (Glass 1961: 3)

More recent scholars have come to support Glass' view on the grounds that the Poles who entered Britain during and after World War II outnumbered the West Indians, yet their entry did not incite the same intense prejudice. Therefore, since the problem was not one of number, then it was 'one of colour, culture and historical antecedents' (Goulbourne 2002: 33).

Interestingly, in the case of migrant children's experiences in London schools, Glass found that the children of West Indian migrants did not encounter the same harassment encountered by children of the earlier

migrant settlers (such as Jews, Cypriots, Italians, Hungarians, Poles and Indians and Pakistanis). To begin with, the West Indian child population in London at the time was very small, due to the high percentage of single young people among the migrant population, who were also predominantly males. Additionally, many parents who emigrated left their young children behind in their home countries with extended families. This difference in the level of harassment between the children of West Indian migrants and the children of earlier migrant settlers was due largely to the absence of a language barrier among the West Indian children and their teachers and peers. Thus, the fact that they could establish communication immediately meant that they had the advantage of not being categorised as outsiders. Furthermore, there was initially an easier process of accommodation in the school environment because, according to Glass, West Indian parents treated their children with a:

careful, often very strict, old-fashioned manner...and the girls wear clean dresses everyday, the boys clean shirts...there are no obvious signs of exceptional poverty in their dress manner... [and] scholastically, too, they are so far in the middle range. (Glass 1961: 64)

Instead of discrimination towards the West Indian pupils, their white peers displayed a sense of curiosity 'just because they looked different' (ibid.: 65) and often competed for the seat next to them. Glass found that discrimination was found mainly in schools with a larger number of migrant West Indian children, who discriminated against one another in terms of colour, calling each other 'blackie' or saying 'you are blacker than me', a colour-consciousness they had taken from the Caribbean to their new location (ibid.). It was only subsequently at secondary schools that relationships between Caribbean and white English students took on a different phase, when according to Glass, white students were no longer 'colour-blind', and their 'mental climate is then only one of the many contradictory influences to which they are exposed' (ibid.: 65-66). Thus, it was at the secondary level of education that relationships between West Indian and white children became more complex.

#### *Migrants' attitudes and coping strategies*

Before their arrival in Britain, West Indians had very little in common besides being territories under British control. The British West Indian islands are widely scattered, vary in size, with their own special features, unique traditions, self-image, sense of individuality and particular

views of the other islands. Within each island there exist further variations. People from the rural areas do not always share similar ideologies with people from urban areas – including ideologies of ‘race’. According to Caribbean socio-cultural constructions, the island populations range in a continuum of skin colour from ‘white’ to ‘black’ (see Henriques 1968: Chapter 3; Lowenthal 1972: Chapter III; Hoetink 1985). Different colonial histories have also resulted in populations of varying origins, with people who came from Africa and Europe, and sometimes from the Middle East, China or India; and later biological mixing has brought further changes. But, more generally, there exists a social-class hierarchy based on colour, with the lightest people at the top and the darkest at the bottom, and associated colour-class prejudices. Thus, the image of the West Indian middle class and elite resembles very much the image of the British middle class, whom they regard as their model, and sets them apart from their working-class counterparts (see Lowenthal 1972; Henriques 1968; M. G. Smith 1965).

Inter-island rivalry is a well-known phenomenon in the Caribbean. For example, people from the larger islands often view those from the smaller islands as culturally inferior. They, in turn, may criticise people from the larger islands for their air of superiority or their domineering attitude. So while Barbadians are viewed as ‘inferiors from a feudal society, who try to be more English than the English’, Jamaicans are often characterised as ‘aggressive’ (Glass 1961: 93-94). Occasionally, these differences in attitudes were manifested in quarrels and fights in factories and Caribbean clubs in London. Moreover, middle-class West Indians were often seen as remaining aloof from their working-class counterparts (*ibid.*).

Despite the different experiences and ideologies they brought from the Caribbean, upon arriving in Britain, they experienced a common feeling of being outsiders and mutual strangers. Not only were people from different islands now living side by side with each other in concentrated areas of London, but most could only afford rents in cramped and crowded lodgings. Glass describes the typical situation as one in which a family or several single migrants shared a room – often small – which served as bedroom, cooking and eating and leisure area. The furniture was usually very meagre, and sanitary and washing facilities typically shared with other tenants (*ibid.*: 54). Hence, having little choice but to live side by side, they underwent a change in relation to each other. Furthermore, as far as the indigenous British population and other groups were concerned, West Indian peoples were all characterised as ‘Blacks’ or ‘Jamaicans’, categories that would have offended many before they arrived (for example, those of mixed parentage and non-Jamaicans). Thus, it was upon their arrival in Britain that people from the Caribbean islands realised

much of their commonalities and, on this basis, they created and developed ethnic bonds that do not exist in the same way in their home regions (see Goulbourne 2001a, 2002; Byron & Condon 2008: 7-10).

Goulbourne cogently illustrates how the creation and development of new ethnic bonds among people from the Caribbean is reflected in several British practices that have come to define the Caribbean in Britain.

The participation of Jamaicans in the (originally Trinidadian) Notting Hill Carnival, the growth and popularity of reggae (originally from Jamaica) in Britain, the display if not quite embrace of the Rastafarian lifestyle far beyond its narrow following in Jamaica, and the use of terms such as 'African-Caribbean' or 'African Caribbean' that have little or no meaning within the region itself. (Goulbourne 2002: 29)

In short, before migrating to Britain, most West Indians, although aware of their historical African background, had been more aware of their British connections. But due to their mainly negative experience upon arrival in Britain, they were now forced to forge a new and common identity (see Glass 1961; Goulbourne 2001a, 2001b; Byron & Condon 2008).

#### *Caribbean and white British mixed sociability*

When did Caribbean people and the indigenous British people begin to mix socially? And what were the attitudes to this, of individuals from both the white and the West Indian populations? As we have seen, social interactions began in the workplace and in schools and, to a lesser degree, in some living accommodations that West Indians shared with people from the poorer sector of the host society. There were also places such as churches, voluntary welfare and leisure associations, children's societies, sports clubs and interracial associations, where contacts were made between the West Indian and the indigenous population. However, on the whole:

These organizations tended to be the asymmetrical type of association where something is done *for* the applicant, rather than the symmetrical assemblies of like-minded where members cooperate *with* each other for certain ends. (Patterson 1965: 226)

For example, the 'interracial associations', which were set up by white sponsors as a way of bridging the 'colour barrier' through bringing people of different colour together, failed on the grounds of too few white



members, lack of common interests, differences in cultural expectations regarding the types of activities and colour consciousness (*ibid.*: 225-245).

Outside of these associational contacts, there were also informal social contacts and intimate relations between the West Indians and the local white people. Research conducted during the period of early West Indian settlement in London gives a mixed view. Banton's (1955) work in the Stepney dockland area reported far less social contact outside work than Patterson's (1965) study of the much larger West Indian population in Brixton. But both were researching in the 1950s when the West Indian (and other black) population was predominantly male. Hence, relationships with British women were the common experience for these men – and more so in Stepney than in Brixton. And in both contexts, they found that mixed-relationships and marriages were, on the whole, not accepted by the mainstream British population.

Banton concluded that the women who married these immigrant men were largely from outside the local district. He said that they 'rarely retain strong ties with their own kinsfolk' (1960: 120), were 'outcasts from white society' with a 'background of deprivation' and were 'psychologically abnormal' (*ibid.*: 127). Essentially, these were women who were 'incapable of conforming to the standards of her own group' and therefore more likely to be drawn to 'coloured men' (*ibid.*). Consequently, the couples and their children socialised largely in a 'coloured' social environment.

From her Brixton sample, Patterson reported a dozen mixed marriages between Englishwomen and West Indian men, half involving 'old-timers' who were skilled artisans or clerks and had been Brixton residents since World War I. The wives of these old-timers came mainly from upper-working-class backgrounds, they themselves having experienced an 'initial period of rejection and disapproval by their own families and friends' before an eventual stage of partial or full acceptance (Patterson 1965: 251-252). With regards to sociability, Patterson reports that the friends and acquaintances of these couples were usually 'white people', perhaps due to their small number and the length of time that these old-timers settled in South London and the result of the 'acculturative process' overtime, whereby they 'adapted to local ways' and had been 'accepted in the local society' (*ibid.*: 252). Outside of these half-dozen old-timers, the other cases of mixed marriages in Brixton involved younger 'coloured' professional men who had met their wives during the War or during their years of study in Britain. These English wives came from similar social and economic backgrounds to that of their husbands and, unlike the wives of the old-timers, they were – due to their militant opposition to any form of colour bar – strongly identified with their husband's group. Thus, much of their leisure time was spent with 'coloured people or liberal-

minded whites from a similar socio-cultural background' (ibid.: 253). As with the disapproval of such relationships found by Banton, Patterson found that, on the whole, although this handful of mixed marriages in Brixton were successful, they did not succeed in changing the generally unfavourable local attitudes to such relationships and marriages (ibid.).

In her cross-London research, Glass (1961) gives a plausibly balanced view on the attitudes of people both in the host society and among the newcomers. She found the general attitudes of members in the host society towards the West Indian migrants varied according to the social-class status of the migrant. Thus, the middle-class West Indian's status allowed him to live and work in a 'protected environment', where his neighbours and colleagues did not regard him as a threat to their status.

He shares their interests; he speaks their 'language'; his manners, his clothes and his routine are the same as theirs (or just as varied as theirs). And if he does seem different, he may be accepted for that very reason. He is often in a circle where it is the non-conformists who conform; where individuality or eccentricity (if only of a particular kind) is welcome. (ibid.: 107)

Thus, the West Indian doctor or social worker, a journalist, a jazz player or a student spent much of his time among people who were neither strange to him nor saw him as strange. It was only when he ventured outside his immediate group that his colour became an issue.

This situation contrasts with the West Indian manual labourer. As Glass points out, most West Indians who migrate do not come from the lowest ranks of their own society and had therefore never thought of themselves as working-class before they arrived in Britain. Many who had been employers in the West Indies became factory hands in London, and some women who had had their own maids in the Caribbean had become kitchen maids in Britain. The people among whom they now lived and worked did not correspond to their prior idealised image of the well-to-do British. Furthermore, to their neighbours and co-workers, they were foreigners. Hence, there was a sense of mutual strangeness.

For in an atmosphere of insecurity, any outsider is a competitor. In the confined quarters of working class districts, there is not much room for any deviation from the norm... The newcomer is expected to obey the varying specific rules. (ibid.: 107)

Thus, while the migrants soon discarded their idealised textbook notions of British people, the British held onto their ‘pessimistic, though ambivalent, stereotype notions of coloured people’ (ibid.: 108).

While sometimes personal acquaintance helps to modify mutual strangeness, in general, the barriers between ‘natives’ and newcomers, erected by the stereotypes on both sides, were still maintained (ibid.: 108). Glass concluded that resentment of ‘coloured people’ in Britain was most evident in neighbourhoods ‘where the coloured are most likely to be thought of collectively – as intruders, competitors and “invaders”’ (ibid.: 124). In line with Banton and Patterson, she also points to resentments with respect to sexual relationships. Taken collectively, the findings and conclusions of these early studies suggest that the experience of sociability between West Indians and white British people – with some exceptions – was rife with resentments and stereotypes on both sides.

In the early 1970s when Benson conducted the first substantial study of twenty *Interracial Families in London* (published in 1981), she again found that the social relationships between individuals from different ethnic groups in Brixton were ‘relations between stranger, albeit strangers who might well live in the same street or work in the same factory’ (Benson 1981: 48). Outside of work, most interactions across the colour boundary developed in what she terms ‘neutral arenas’, such as the marketplace, and involved only limited social relationships. There were other forms of ‘guest-host’ relationships that were temporary and situational – ‘such as when Englishmen visited a West Indian rum café to buy “ganja” (cannabis)’ or ‘when a Jamaican electrician invited his English workmate to attend his family weddings and christenings’ (ibid.: 48). Patterson points out that such interaction did not, however, negate the colour or ethnic boundary. Furthermore, such relationships were unproblematic between same-sex individuals, but were regarded as problematic when women and men of the different groups were involved. She concluded that English, Scottish or Irish women who had West Indian male partners were not regarded as respectable in the eyes of the wider ‘white’ community, and were thus marginalised to the ‘black Brixton world’ (ibid.: 49).

### **The current situation**

Since Benson’s work 39 years ago, no research has been done in London – or in Britain – exploring specifically the social relationships between Caribbean and white British people. Additionally, outside Wallman’s research entitled *Eight London Households* (1984), in which she also explored two West Indian households, no in-depth

**Table 1.3** *Caribbean population in Britain, 1951-1991*

<i>Year</i>	<i>Caribbean birthplace</i>	<i>British-born children of West Indian-born</i>	<i>Best estimate Caribbean population</i>
1951	17,218	10,000	28,000
1961	173,659	35,000	209,000
1966	269,300	133,000	402,000
1971	304,070	244,000	548,000
1981a	295,179	250,565	546,000
1981b	268,000	244,000	519,000
1984	242,000	281,000	529,000
1986-1988	233,000	262,000	495,000
1999	264,591	268,337 – 326,443	499,964 – 558,070

*Source:* Peach (1996: 26)

investigation into the extended Caribbean family in Britain has ever been carried out. As Goulbourne observes (2001a: 25), this is somewhat surprising, given that discussions about problems faced by communities in Britain are nearly always informed by general assumptions about their family and kinship patterns. Debates regarding the Caribbean community and employment, education, housing, the police or child welfare have generally incorporated specific notions about Caribbean family life, customs and traditions (see e.g. Dench 1992; Barn 2001). However, with the exception of Reynold's work on Caribbean fathers (Reynolds 2001) and her work on Caribbean mothers (Reynolds 2005), there is a lack of qualitative studies on Caribbean family life in Britain.

By the 1970s, the hostile political and local reaction to the influx of West Indians – and to some extent, the impact of their numbers on housing and the fluctuating labour market – had resulted in the imposition of immigration controls on colonial British subjects, removing their right of free entry by a series of key new legislation from 1962 to 1971 (see Goulbourne 2002; Marwick 2003; Rosen 2003). Following this, the growth of the West Indian community sharply slowed down (Table 1.3), with a current total of migrants and their descendants of approximately 600,000 (Office for National Statistics 2002), now sustaining itself more through children born in Britain than from new migrants. Additionally, over time, the communities shifted from being mainly composed of young migrants to mixed aged, with both children and grandparents present. Another particularly striking long-term change – as shown by the statistics earlier – has been the rate of inter-marriage with white partners. After dipping sharply in the 1960s and 1970s with the arrival of more Caribbean women, the rate had risen

among young African-Caribbean men and women to a very high level (Berthoud 2000; Platt 2009).

### **What has been investigated?**

It is estimated that Britain currently has the highest rate of intermarriage and children of mixed parentage in the Western world, among which the largest mix is African-Caribbean and white British individuals (Alibhai-Brown 2001: 77). It is not surprising – given the rise in intermarriage between African-Caribbeans and members of the white British populace over time – that current surveys on British Social Attitudes reflect a higher level of tolerance to such marriages and families than in the past (see Alibhai-Brown 2001; Madood, Beishon & Virdee 1994). However, despite this growing phenomenon in Britain, overall, and in London, in particular, there has been no research to date on the wider families of these individuals.

Two attempts have so far been made to investigate mixed marriages between Africans and white British couples and between West Indians and white British couples. The first was Hill's (1965) inquiry into 36 mixed marriages in north London, which was part of a wider research project entitled 'Colour Prejudice in Britain'. Hill's survey revealed that 91 per cent of the white population they interviewed in north London disapproved of mixed marriages between 'white and coloured people' (Hill 1965: 209). The second was Benson's more in-depth PhD research (mentioned earlier), conducted in the early 1970s (and published in 1981), looking at twenty working-class 'interracial' couple households comprising African and white British backgrounds and West Indian and white British backgrounds. Benson concluded that in British society 'where ethnicity is a significant component of social identity and an important principle of association and dissociation in social life' (Benson 1981: 1), people in 'interracial marriages, "mixed" marriages between "white" and "coloured" [have an] ambiguous position' (ibid.: 1). Their ambiguous position is not only externally imposed, but also arises from their own ambivalent feelings about ethnicity. Whatever strategy they used to deal with their ambiguous ethnicity, whether successful or not, has social costs and benefits. As Benson (ibid.: 133) notes: 'These costs and benefits were reflected especially clearly in the problems faced by the children of these interracial couples'.

With regards to Benson's work – apart from the problems with her discussion of children's identity – had she focused on a more culturally coherent group, her findings might have offered some very different explanations with regards to 'ethnicity' and 'mixing'. It is well known that the cultural attitudes of Africans and West Indians are different; a pertinent

example is their attitudes towards skin colour. The term 'coloured' implies a mixed origin of part European and part African blood. While it might be insulting to a Nigerian or a Ghanaian to be called 'coloured', because most Africans find such mixture undesirable, many West Indians are proud of the mixture, because in their societies of origin, skin colour corresponds with class status – the lighter the colour of the skin, the higher up the social scale (see Hill 1965: 12; Henriques 1968). Benson herself noted that West Indians and West Africans 'felt themselves to be very different people, with very little in common' (Benson 1981: 39-43).

Of other in-depth qualitative works done in Britain thus far, the focus has mainly been on the children of mixed 'black and white' parentage and issues of identity formation. While the earlier studies of West Indian – and African – settlement in Britain in the 1950s and 1960s were mainly sociological, with an emphasis on race relations, many of these studies were informed by assumptions of a 'problem' for children of mixed parentage. The popular view, repeated in the earlier research, had been that neither the 'black' nor the 'white' community accepted children born of mixed marriages, who therefore developed identity 'problems' reflecting their ambiguous social positions (see Banton 1955; Hill 1965; Little 1947; Richmond 1955). However, from the 1970s, researchers painted a more optimistic picture (see Bagley & Young 1979; Durojaiye 1970; Wilson 1987; Alibhai-Brown 2001; Tizard & Phoenix 1993, 2002; Caballero, Edwards & Puthussery 2008). They demonstrated that this assumption was unfounded, unsupported by sound empirical evidence, so that conclusions were drawn from 'a mixture of impressionistic observation, popular myth and theoretical analysis of race and racism in Britain' (Wilson 1987: 16). The more recent studies showed that 'mixed-race' children identified with both their 'black' and 'white' peers (Durojaiye 1970), and that their evaluation of colour was based on positive evaluations of both of their parents. Furthermore, their positive identification was reflected in high levels of self-esteem (Bagley & Young 1979).

Benson's study of 'interracial' household families in Brixton is the only post-1960s research that paints a less optimistic picture of the identity of children of mixed parentage, and her data on the children warrant some caution. While her primary focus was on the *identity of the couples* rather than on the children's identity, on the basis of very little first-hand – or as she terms it, 'incomplete information' (Benson 1981: 143) – Benson endorsed the 'problem' perspective of the earlier studies. And although the 27 children in her study ranged from a few months to twenty years of age, she drew conclusions about their friendships and identity not from the children's own accounts, but from incidents she observed or accounts given by their parents. She reported that many of the children in her sample had 'identity problems', as

indicated by their denial of 'black' identity, a desire to 'change their appearance so that they looked more like whites' or trying to 'wash off their "dirty" brown skin' (ibid.: 143). Benson argued that:

In a racially divided society, where differences of ethnic origin are of primary significance in establishing social identity, the future lives of such children must, inevitably, be fraught with difficulties. (ibid.: 144)

Given the unsystematic and second-hand nature of Benson's information, it is questionable whether her findings and conclusions accurately reflect the views of the children in her study in a small area of London, let alone children of similar parentage in all of London. Instead, her findings and conclusions appear to have fed into the anxieties of the parents about their children, especially when compared with findings from other studies that were conducted around the same time, which illustrated positive identification among 'mixed-race' children (see Bagley & Young 1979; Durojaiye 1970).

The only British researchers who have subsequently addressed, in depth, the issue of 'identity' in mixed-parentage children living with their own parents, have been Wilson (1987), Tizard and Phoenix (1993, 2002), and Caballero, Edwards and Puthessery (2008). These studies looked at children living in 'black' areas, 'white' areas and 'mixed' areas, and from working-class as well as middle-class backgrounds. Wilson's study of 51 six- to nine-year-old British children, with one white parent and the other African or African-Caribbean, found that 'many children seemed to have found a happy and secure identity for themselves as "black mixed race"' (Wilson 1987: vi). Tizard and Phoenix's 58 adolescents were from similarly mixed family backgrounds and social classes. These studies found little evidence of 'identity' confusion among their participants. Rather, they demonstrate the difference between the findings and conclusions based on scanty evidence and common assumptions, and those formed from systematic empirical evidence.

More recently, Twine's (1999) work on 'white' mothers of 'black' children in Britain has been exploring the acts of 'antiracism' in which such mothers engage in their daily lives. Twine argues that white mothers of African-descent children in Britain differ from the white mothers of white children in that they 'may have to prove their maternal competence to black family members as *white* mothers in multiethnic families' (Twine 1999: 730). Consequently, in contrast to black mothers of black children (and to the white mothers of white children):

They may subject themselves to the close surveillance, evaluation, and, sometimes harsh criticism of their Black family

members to insure that they are culturally competent as the mothers of Black children. (ibid.: 744)

Twine further highlights how white mothers who raise their children to self-identify as 'black' must not only 'ear their whiteness in ways that are different from the white mothers of white children' (ibid.: 730), but struggle to counter a harsher degree of everyday racism (ibid.: 744).

It does not take the evidence of such literature or a census to become aware of the extent of social mixing that has evolved in London over the past 50 years between African-Caribbeans and white British people. This phenomenon is evident in nearly all aspects of individuals' lives: schools, churches, workplaces, entertainment and leisure activities and neighbourhoods. Given this history of social relationships between African-Caribbeans and white British people – and the rate of intermarriage and family formations between these two groups – why have these families gone uninvestigated? What has been done on British kinship within the last 50 years? How might these studies inform my research? These are the questions that the following chapter sets out to explore. However, before doing so, I turn first to methodology.

## Methodology

### *The research process*

Methodologically, the research process is sometimes described as a linear progression. In this conceptualisation, the researcher begins with an idea, gathers theoretical information, develops a research design, collects and analyses the data, then reports the findings: the theory-before-research model (Nachmias & Nachmias 1992: 46). In effect, tasks are completed in stages with each stage considered complete as the research progresses forward.

My own research model proved to be one of a more cyclical or spiralling process, resembling the classic approach of Glaser and Strauss' (1967) 'grounded theory'. It began with an idea derived from my own inquisitiveness about a group of people about whom very little is known. It was followed by a literature review that provided me with theoretical concepts and some existing approaches to help formulate and refine my ideas. Next, I designed methods for data collection, followed by actual data collection. Data collection and analysis led me to re-examine and rethink theoretical approaches as new explanations emerged from the data. This ensured a constant re-examination of each stage of the research process. The process lasted approximately four years from June 2002 to September 2006. It involved eighteen months of



fieldwork that included participant observation and interviews, six months of transcribing 98 interviews and eighteen months of writing up.

### *The sample*

The group on which my research is based consists of 34 mixed African-Caribbean and white British extended families in London across three and four generations. I originally thought of conducting my investigation in a single borough in order to maintain an anthropologically tidy tradition. However, very soon into my fieldwork, I realised that it would be impractical to restrict the sample to a single borough when intergenerational family residential mobility is taken into account. I also observed how restricting the sample to a single borough or neighbourhood would narrow the social-class range of my families. Unlike Young and Willmott's (1957) East London families or Firth's (1956) middle-class London families, contemporary mixed-heritage families are not contained in a single community. Hence, I obtained participants for this sample through suggestions from people I knew, from conversations at family functions, churches and academic seminars, while standing in lines at banks, train stations and airports, and also by approaching people in public places such as parks, on the streets and on public transportation.

My investigation began primarily with the mixed-heritage couple and sometimes the mixed-heritage child, and continued on to the extended family of both the African-Caribbean and the white British partners, with an eventual investigation of the extended family as a whole. Sometimes I began with a grandparent and worked down and out into the kin universe.

I tried to obtain a balance in terms of the gender and heritage/ethnic combination of the starting couples. Thus, of the 34 families, starting with the initial couple: twelve were made up of an African-Caribbean female with a white British male, three were made up of a mixed female (African-Caribbean and white British) and a white British male, while nineteen were made up of a white British female and an African-Caribbean male (Appendix II: Tables 1-6). The household couples consisted of: eleven parents who were legally married and still living together, six who were legally married but had parted ways from one another, eight who were cohabiting, five who were cohabiting but had parted, three in 'visiting' or 'extra-residential' relationships and one foster family (Appendix II: Tables 1-6). There were nine families with female-headed households: two were African-Caribbean women of whom two were legally married but since parted, one mixed-race woman (African-Caribbean and English mix) and six were white British women,

two of whom were legally married but since parted (see Appendix II: Table 7).

### *Children*

In the sample of 34 extended families, there were numerous children of both African-Caribbean and white British ancestries across three to four generations. There were 26 households with children still living at home. Eighteen of these households consisted of only mixed-race children and eight consisted of a combination of mixed-race and black children, mixed-race and white children or mixed-race, white and black children all in the same household (Appendix II: Tables 1-7). In particular, however, I was aware of 127 mixed-race children, among whom, were 29 adults and 98 children ages six months to nineteen years old (these included grandchildren and great-grandchildren, nieces, nephews and cousins in the extended family). I made contact with fifteen mixed-race adults and 43 mixed-race children between the ages of one-and-a-half and nineteen years old.

### *Sample bias*

Because there was no basis available for a random sample, I used the strategic sampling approach. Thus, I recognise the limits regarding the generalisability of the findings and conclusions. One particular limitation is in the gender bias in the older generation. While, among the current families, there is more of a colour/gender balance, among the earlier families, there are more white British wives with African-Caribbean men. However, this is no accident. Because male immigrants from the Caribbean in the 1950s far outnumbered women (Foner 2009; Byron & Condon 2008), mixed marriages were largely between Caribbean men and white British women. It was only from the late 1950s that many men began to send for their wives, and also a large number of women from the Caribbean began to arrive independently in search of work (see Byron 1994, 1998; Peach 1968). Hence, up until the 1960s, there were always fewer marriageable Caribbean women in Britain than men (Hill 1965: 215-216). In my sample there is only one such family. In his sample of 36 mixed marriages, Hill found only two such couples. By the early 1970s, in her sample of twenty couples, Benson's study included two African women and two Caribbean women. These limitations considered, my findings must therefore be seen as exploratory rather than as definitive.

## Methods of data collection

Regarding contemporary research practice, Clifford (1992: 98) notes: 'Despite the move out of literal villages, the notion of fieldwork as a special kind of localized dwelling remains'. Thus, contemporary anthropologists are increasingly calling for re-evaluation of traditional anthropological methods to accommodate for the increasing mobility of people whom they study (see Amit 2000; Bauer & Thompson 2006; Horst & Miller 2005; Hastrup & Olwig 1997), as well as for the increasing number of studies being conducted in urban and diasporic contexts.

There is no denying that conducting ethnographic fieldwork in dense urban cities requires modifications of the traditional paradigm of participant observation. Given that people's lives and activities are fluid, exploring 'the field' for me required different approaches ranging from regular visits with some families and face-to-face interviews, to periodic visits with others, informal chats, emails and telephone calls. Therefore, in conducting fieldwork, it was often 'the circumstance which defined the method rather than the method defining the circumstance' (Amit 2000: 11). The evidence from my ethnography thus throws light both on what people do and also on what they say they do. Wallman (1984: 43) warned against mistaking the perspectives of participant observation with the method itself.

In the popular image, social anthropology is a technique of inquiry, nothing more. By this metonymic logic, its means are equated with its ends, its method with its methodology; if it is not possible to 'do' participant observation – which, in the traditional paradigm, requires year-round isolation from one's own ordinary life and round the clock immersion in the lives of others – then it is not possible to 'do' social anthropology. In these terms it is difficult to work as a social anthropologist in any town and impossible in your own... Participant observation is a means to understanding social life in the round, to the appreciation of context and meaning, and to the relational perspective, all of which are distinguishing marks of social anthropology.

Thus, contemporary anthropologists (see e.g. Amit 2000; Hastrup & Olwig 1997; Oakley 1992; Knowles 2000; Norman 2000; Olwig 1999) remind us how it is the understanding of context, meaning and social relationships that are still crucial to social anthropology. Moreover, this can contribute to the understanding not just of urban lives and phenomenon, but other broadly contextualised phenomenon. In the process, such understanding helps to deconstruct and break down the distinction between 'them' and 'us', and challenges the reifications of

other cultural concepts. It was these insights that gave me the courage to embark on ethnographic fieldwork in a large urban centre such as London, and across three and four generations.

For data collection I employed a triangulation technique that included: library research, the collection of British census data on ethno-racial groups, in-depth semi-structured, face-to-face tape-recorded interviews and participant observation. Additional telephone calls and emails were made to participants when further information or clarifications were necessary. I also received emails and telephone calls from participants who wanted to 'just say hello' or to pass on additional information.

### *Library research*

Existing literature on Caribbean family and kinship studies as well as on British family and kinship studies were reviewed for comparison with my data. Historical literature on race relations in Britain and Caribbean migration to Britain was also reviewed for contextualisation. Census data on Caribbean settlement in Britain and on ethnicity were also reviewed. The literature and census not only provided valuable information, but also stimuli for useful questions while interviewing and observing participants.

There has been a long tradition of using life stories in anthropological research. Mintz's *Worker in the Cane: A Puerto Rican Life History* (1960) and Lewis' *Children of Sanchez* (1961), which gives accounts of members of the same family, are both classics demonstrating the strength of the life story tradition in anthropology. Among more recent works, I have also been influenced by Tonkin's illuminating book *Narrating Our Pasts: The Social Construction of Oral History* (1993). Based on her anthropological fieldwork in West Africa, Tonkin argues that we need to understand how different kinds of contexts produce different kinds of accounts of a life story (so one could contrast accounts in a one-to-one interview, a couple interview, at a family occasion, etc.). Caplan's *African Voices, African Lives* (1997) is also notable as an instance of an anthropologist giving priority in interpretation to her informant's relevant 'view of the world through his own words' (Caplan 1997: 18). Additionally, I have been influenced by Thompson's (2000) methodological discussion of the oral history/life story approach. Thompson shows how oral testimonies can be used to establish and interpret past patterns of social change, particularly of family and community relations, and to understand the significance of these changes from the narrator's perspective (see also Besson 2002a). Finally, Besson and Olwig's *Caribbean Narratives of Belonging* (2005), with empirical data on the lives experienced by

various Caribbean people, offers insights into the notions and practices of belonging in different social, political and cultural contexts – including Britain.

### *The interviews*

I conducted 98 in-depth face-to-face interviews with members in 34 mixed-heritage English-speaking African-Caribbean and white British families in London across three to four generations. The interviews were semi-structured, conversational and followed a broad life history approach, exploring family and social/cultural background and their community context as well as personal relationships. Questions were adjusted to correspond with the different relationship categories. The interviews varied between one and five hours long.

I interviewed couples (some together, some individually), parents, children (the youngest were age eighteen), siblings, and various other members in extended families such as grandparents, aunts, uncles, cousins and other fictive kin members in order to explore the patterns of these relationships over generations. For example, are relationships continued in the family over generations? Are they forgotten about? Do they become significant elements of family history? Are they seen as positive, negative or of no consequence to the family network? Additionally, family genealogies were collected from each family in order to observe any patterns or trends (or lack thereof) in the formation of mixed families and the life paths taken by kin members in each generation in terms of education, work, patterns of residence and family (as in legal marriage, cohabiting/common-law or visiting unions (see Appendix III)) and the nature of relationships, contacts and exchanges between kin members.

### *Participant observation*

Participant observation was carried out in various ways. I made regular visits to homes of families and sometimes even stayed with some families for a few days. I participated in many family activities such as accompanying parents to pick up their children from school, helping children with their homework and babysitting. During the summer of my fieldwork, I also did activities with some children independent of their parents. For example, I took some children out on daytrips to various places in the city such as the zoo, the Science Museum and the movies. These occasions with the children gave me insights into children's perceptions of relatedness, which were sometimes different from their parents' perceptions.

I attended numerous family functions such as barbecues, birthday parties, children's baptisms and christenings, three weddings and a funeral. I was also invited on occasion to some social clubs and church services. Additionally, I regularly went on social outings with individual family members to picnics in parks, the movies, art galleries, dance clubs and pubs. Sometimes I had them to my home for supper.

Outside of physical contacts, I made regular contacts with people via email and the telephone. These forms of communication connected me with key participants and their social activities while I was absent from the field. Some families also phoned me regularly for informal chats and to update me on family matters. On four occasions, family members called to inform about their sick relatives, so I went to visit them in the hospital and, later at home, after their discharge.

### *Data analysis*

A major goal of the field research process is to capture the complexity of the phenomena under investigation – to get the insider's view of reality – and to make convincing sense of it (Strauss 1987). Some researchers believe that fieldwork should be *deductive* – following the *theory-before-research* model – whereby certain observable consequences are deduced from existing theories. Others take an *inductive* approach that begins with the researcher 'immersing' herself or himself in the field documents in order to identify the meaningful themes (Berg 1995: 180). Glaser and Strauss (1967) refer to theory that is generated from the data as 'grounded theory', distinguished from theory that is derived from prior assumptions. The grounded theory approach advocates flexible research designs that allow themes, patterns and theoretical explanations to emerge from the field data.

For my research, I found that using a combination of deduction and induction was the best approach in analysing the field data. Deduction seemed sensible because I had entered the field with initial ideas and research questions that were developed in combination with ideas from literature that directed my data-gathering effort. Therefore, I needed to verify, if not identify, the larger meaning of my findings as they related to the existing theoretical frameworks. Grounded theory (induction) was useful because my objective was also to discover new explanations for the particular phenomenon under investigation.

Systematic analysis of the ethnographic data began during transcription, when I began to extract themes, topics and issues in a systematic order. This continued with the reading of the transcripts and other field notes, and it was during this stage that themes and patterns in narratives, conversations and activities of individuals began to emerge. An approach akin to inductive content analysis (ibid.) helped me identify

the frequency of themes and patterns in the data, and to organise, code and tabulate them in a manner allowing for cross-reference and verification. The use of ethnographic narrative – ‘thick description’ (Geertz 1973) – helped to render as detailed as possible a picture of the past and present (told by individuals) and observed events. It allowed me to look closely at the individuals involved, the roles and rules associated with certain activities and events and the social contexts in which these factors arose.

There are many common themes and patterns running through all the families in the research. Examples of some common or typical features that emerged across the 34 families include: individuals’ tolerance of diverse ‘others’ and their willingness to mix socially, experiences of racism, the need to devise coping strategies to survive both within their families and in the wider society, experimentation and innovation in creating their kin networks, the significance of women and children in making kinship (women are the main agents in forming and maintaining kin networks, while children create the links between families), the creation and maintenance of the kin universe that involves an extensive network of blood, affinal (relatives through marriage) and fictive relatives and, the importance of family history and experience in the inclusion of kin.

However, although these themes and patterns are typical across the 34 families, there is considerable variety among the families in how they are practised and experienced. Therefore, in order to avoid broad over-generalisations, I have used micro studies of individual families to illustrate the diversity in the group as a whole. Essentially, through the use of family case studies, I have shown how members in particular families relate to each other and organise their lives, given individual choices and the influences and constraints of others in their family and of the wider social forces. Such studies are also very valuable in that – in contrast, for example, to thematic analysis when individuals, rather than whole families, are usually the unit of analysis – a family case study enables us to explore as a single system the complex interaction of a large number of kin roles and actors.

Thus, I believe that as cases in the anthropological tradition, they effectively ‘illustrate aspects of social process and demonstrate certain theoretical principles’ (Wallman 1984: vii). Although about particular families, each different, they raise a number of the issues that are central to the understanding of family and kinship behaviour across all the families and of individual experiences in Britain, overall, and London, in particular.

## Challenges in conducting research

Conducting research in a dense, hyper-diverse city such as London posed many challenges. To begin with, researching mixed-heritage extended families meant travelling to various locations within the city. Secondly, managing time and scheduling visits and interviews at everyone's convenience was not always easy. However, the most challenging experience I faced came after completing my fieldwork. That was, how to leave the field? Unlike most of my peers who went to remote locations to conduct their research, in my case – although fieldwork in London as a Jamaican-Canadian means fieldwork 'abroad' – as a student living in her fieldwork site it also means conducting fieldwork locally. I have made some very good friends among the families, and not only am I still being called regularly with added information, but I continue to get invitations to family social events. Through the research process, then, I have come to realise how, as Amit (2002: 2) pointed out:

The onus towards comradeship, however incompletely and sporadically achieved, provides a vantage point imbued at once with significant analytical advantages as well as poignant dilemmas of ethics and social location.

## Defining key concepts and terms

'Caribbean' and 'West Indian' are terms often used interchangeably and with uncertainty. This study focuses on people from the English-speaking Caribbean territories, with their similar cultural traditions, common language, educational system and so on. 'African-Caribbean' will refer to anyone from the English-speaking Caribbean countries with primarily African ancestry (I sometimes use the word interchangeably with 'Caribbean'). 'First-generation African-Caribbean' will refer to people who migrated to Britain from the Caribbean; 'second-generation African-Caribbean' will refer primarily to the children born in Britain of first-generation African-Caribbean migrants, but also those who came to Britain as young children; 'third-generation African-Caribbean' will refer to the grandchildren of first migrants. 'Mixed sociability' refers to the social relationships between Caribbean and white British people. 'Creole', a concept applied with varying connotations (for overview of the different usages, see Allen 2002), generally defined, refers to a local product (people, language, style and/or culture) that is culturally distinct, and is the result of a mixture or blending of various ingredients from non-native origins. 'Creolisation' – the theoretical framework used



for analysis of this study – refers to the ‘processes of cultural change that give rise to such distinctiveness’ (Bolland 2002: 15-16).

### *‘Race’ and related concepts*

After reviewing the corpus of definitions and explanations of ‘race’ and its related concepts, what became clearest to me is how arbitrary and therefore problematic the concept is when it comes to classifying human beings. Barrett (1994: 21) sums up the controversy very cogently:

On the one hand, racial classifications based on observable physical appearance (phenotypes) have long been discarded by the academic world because they lack scientific validity; more recent attempts to employ genes and chromosomes as the basis of classification (producing genotypes) have not fared much better, due to the obstacles against experimental control, and to the measurement problems posed by a complex organism: namely, the human being. On the other hand, lay people often act *as if* a biological classification, especially in the phenotypical sense, is meaningful, and their beliefs, regardless how erroneous, have consequences for social life which the investigator cannot ignore. Even academic specialists who dismiss racial classifications as misleading fictions find it difficult to avoid using common terms like white and black, or Caucasoid and Negroid, and, of course, ‘race’ itself.

For the purpose of my study, ‘race’ refers to the socially constructed classification of human beings based on historical and social context, their experiences as a group and the popular usage of the term in academic and everyday discourses, including participants’ own usage. ‘Racism’ refers to the varying forms of prejudice and discrimination based on the uncritical acceptance of negative social definitions of a subordinate group of people typically identified by physical features (James 1999).

Although the terms ‘black’ and ‘white’ remain problematic (for issues regarding the concept ‘black’ see Aspinall 2008; Maylor 2009; for those regarding ‘white’ see Bush 2004; Bonnett 2008; Essed & Trienekens 2008; Song 2010; Twine & Gallagher 2008), in particular instances, the terms will be used to refer to individuals based on *their* identification with a particular reference group. I have already acknowledged the inclusion of the ‘Irish’ category in the 2001 census. However, based on geopolitical inclusion and on self-identification, for the purpose of this study, ‘white British’ will refer to people of British ancestry, including the individual from Ireland who identified as ‘British’. ‘English’ and

'British' are sometimes used interchangeably depending on how individuals defined themselves.

Due to the growing number of relationships and intermarriages across ethnic groups in Britain today, there is a large number of individuals born into these families who identify themselves as 'mixed' and 'mixed-race', because they wish to declare their 'mixed' identity in terms of race and ethnic group (Ali 2003, 2007; Caballero 2007; Caballero et al. 2008; Sims 2007; Song 2003, 2007, 2010a). For example, in the 2001 census, different types of 'mixed people' identified themselves as 'Black/White', 'East Asian/White', 'South Asian/White', and 'Arab/White' (Song 2010a, 2010b; Aspinall 2009a, 2009b; Owen 2007). Moreover, current research has shown that the most common term of choice among respondents born of inter-ethnic and racial unions is 'mixed race', followed by 'mixed heritage' (Aspinall 2009a, 2009b).

In my study, 'mixed race', 'mixed heritage' and 'mixed parentage' are self-ascribed terms that individuals of mixed African-Caribbean and white British parentage used to describe themselves. Therefore, I will refer to them as such. 'Mixed heritage' is sometimes used interchangeably with 'mixed parentage'. *Ethnicity*, like *race*, is a socially, politically and historically constructed concept (see Back & Solomos 2000; Bulmer & Solomos 1999; Goulbourne 1991; Hall 1992, 1996b). The two concepts are often close, but they are not easily reducible to the same category. For the purpose of this study, 'ethnicity' will refer to the shared cultural heritage of a group of people such as common ancestry, language, music, art or religion.

### *Forms of marriage and conjugal patterns*

'Marriage' here refers to the socially sanctioned form of heterosexual mating and co-residence, establishing duties and commitment with respect to sex and reproduction. 'Intimate relationship' refers to couple relationship including sexual intimacy. 'Legal marriage' refers to marriage that is legally recognised in a church by a priest or in a registry office by a registrar. 'Cohabitation' will be used interchangeably with 'common-law marriage' to refer to a form of marriage similar to legal marriage – minus the legal recognition – in that the couples have a consensual arrangement to share the residence and a mutual emotional and practical conjugal commitment. 'Visiting relationship' refers to couples who are in conjugal relationships but are not committed to establishing a common household, and who have less conjugal commitment than couples in legal marriage or cohabiting couples. Some couples are involved in long-term visiting relationships in which there are expectations of mutual fidelity and responsibility to children born from these

unions (see Besson 2002a: Chapter 8 on the “Complex” Marriage System’ in Jamaica). ‘Family’ refers to members of the nuclear residence of husband, wife and children, and also to the extended kin groups who maintain extensive contacts and exchange help and services among each other, nationally and transnationally. The families in this study have fluid boundaries, and inclusion in one’s family is dependent on the history of the relationships. Therefore, while blood relatives may not be included as family – due to lack of contact and support – non-blood ties such as those created out of relationships that were originally ties of friendship may become important in this system of reciprocity and mutual support, and are therefore often included as family. Included also are non-blood relatives such as those through affinity (marriage), adoption, fostering and step-siblingship.

### *Social class*

There are many criteria for defining social class such as people’s occupation and income, education, housing and their self-ascribed class status. For this study, I have used education and occupation as the primary criteria, but also taking into consideration housing status and self-ascribed class categories.

## **Structure of the book**

There are three parts to this book. The first comprises Chapters 1 and 2, providing the background to the research and the research context, discussing the methodology and addressing the literature on British and Caribbean kinship and creolisation since the 1950s.

The second part of the book comprises three ethnographic chapters that focus on particular extended families, illustrating the main themes of the book. Chapter 3 explores the process of kinship and forms of relatedness among four generations of one family, the Smiths. It illustrates a kinship system that developed through ongoing re-creations and strategic adaptations and negotiations not only within the family, but also within the changing social context of London from the 1950s to present. It provides an introduction to how people in the research families speak and ‘do’ kinship and the creative adaptations/transformations that they have innovated in the changing London context over time.

Chapter 4 elaborates, through analysis of Gobi’s family, one main theme in the previous chapter and in the book: the agency of women in the making and maintenance of the kinship network. Here, the focus is women’s agency as well as how children are especially significant in forming the links between families. It illustrates the significance of

biological as well as non-biological relatives in kinship. Gobi's family demonstrates a complex crisscrossing of biological and non-biological siblingship that forms the backbone of her kinship network. Hence, relationships cannot be traced exclusively – or even easily – through genealogical relations of filiation or alliance. Instead, relations are more easily traced through the ties or connections between children/grandchildren/siblings. Such connections are further reinforced or symbolised by the common titles they attribute to relatives such as 'Mum', 'Granny', 'Grandpa', 'sister' and 'brother', who are not always blood relatives. Finally, this chapter also shows how the *history* of family relationships can determine who gets included as kin.

Chapter 5 continues from the previous chapter by exploring further, this time with Ken and Verna Morgan's extended family, the significance of family histories in the creation and maintenance of kinship relations. As with most families, the Morgans' extended family relationships did not develop into its current state without a complex history. Thus, an understanding of the dynamics of the relationships I observed was only possible when interpreted in conjunction with the narratives people told of their past. In other words, it is through *the history of their families* that I was able to gain some understanding into the ideas and forms of relatedness people constructed within their current extended family. As Carsten points out, 'for many people time and history are understood in the idiom of kinship and ideas about relatedness' (1997: 13-14). This is true for the Morgan family not only in terms of the development within their own families over time, but also in terms of how the different generations of their families have also been influenced by changes in the social and political context of Britain, overall, and of London, in particular.

The third part of the book draws on all the families to explore more generally the social contexts in which these families have emerged and the ongoing modifications and negotiations through which they have responded to changing circumstances, both within the families and in the wider society. Thus, Chapter 6 traces the growth of social relationships between African-Caribbeans and the white British population from the 1950s to 2003, as experienced by the people in my research. It uses ethnographic detail to show how gradually through everyday encounters, a culture of mixed sociability has developed, and how these mixed-heritage families have evolved and continue to be created from the ongoing processes of social mixing, despite racial prejudice.

Chapter 7 addresses the experience of racial prejudice for individuals in my research families, despite the rise in mixed sociability in the last 50 years. It also explores the innovative strategies family members use to combat colour prejudice through the generations. Finally, it examines 'mixed-race' individuals' understanding of *their* social positions in

British society and the strategies they have innovated in securing their senses of belonging.

Finally, Chapter 8 sums up the main arguments of my research. Thus, this book is an ethnographic description of what the people in the mixed African-Caribbean and white British families in London say and do. Because there are many voices, I have framed cited speech in quotation marks and usually indicate when an individual person is speaking. Otherwise, where words or phrases are framed in quotation marks without reference to an individual implies general speech among various individuals. In order to maintain confidentiality, all the participants in the research have been quoted in this book under pseudonyms. Regarding the tenses in which the book has been written, while I have given accounts of the past in the past tense, accounts of practices that occurred during fieldwork are written in the present tense.

## Note

1 [www.100greatblackbritons.com](http://www.100greatblackbritons.com).



## **2 Outlining and assessing studies of British kinship since the 1950s**

This chapter addresses the literature on kinship in Britain since the 1950s and its relevance to the central themes of the book. Ultimately, I argue that theoretical writings on studies of kinship and family relatedness outside of Britain provide the most useful clues for understanding relatedness among my research families. For example, I found a relevant parallel in Carsten's (1997) interpretation of Malay kinship with a historical dimension and forms of family relatedness, shifting the focus from a social/biological distinction to a more 'flexible and open' and native/local definition of 'relatedness' (Carsten 2004: 311). Additionally, the creolisation/culture-building works of Caribbeanists such as Besson (2002a, 2002b), Mintz (1992 [1976]) and Olwig (1981), with their emphasis on the creative adaptations of Caribbean family patterns as modes of resistance and accommodation, are of particular relevance. For although my research families' networks evolved outside of the Caribbean, the ongoing struggles these families face in London and the continued survival strategies they devise may be compared with the processes that occurred in the Caribbean. First, however, let us look at research on British kinship since the 1950s.

### **Studies of family and kinship in Britain: The 1950s-2003**

Given the British anthropological concern with kinship, it is surprising how little attention British anthropologists have paid to kinship in their own society. During the first half of the twentieth century, among British social anthropologists, the study of kinship became the main focus of empirical research and theoretical explanation. These early twentieth-century anthropologists, armed with a functionalist methodology, relied heavily on Rivers' genealogical method for fieldwork and the analysis of data (Bouquet 1993: 12). However, their interest in social organisation took them to remote parts of the British Empire to study 'primitive' societies, while paying very limited attention to kinship in their own society. There were some early community studies conducted in Britain that included aspects of kinship (see e.g. Arensberg & Kimball 1968; Frankenberg 1966), but with a few exceptions (e.g. Firth 1956;

Firth, Hubert & Forge 1970), British anthropologists seemed uninterested in kinship at home. There was also the community studies work of Young, who trained as an anthropologist but practised as a sociologist (Young & Willmott 1957). Even Strathern's *Kinship at the Core* (1981) continued in the community genre. It was more from sociological works on the extended family that ideas about British kinship could be gained (see e.g. Bell 1968; Bott 1957; Rosser & Harris, 1965; Willmott & Young 1960; Young & Willmott 1957). Furthermore, among these studies, kinship was mostly regarded as 'a local, empirical phenomenon rather than a central British... assumption about social organization' (Bouquet 1993: 15).

Although dated, some of these earlier discussions of British kinship still yield useful ideas. To begin with, Young and Willmott (1957) provide insight into the family as a social institution as it appeared in early post-War (1953-1955) East London. Contrary to the assumption of many sociologists of that period, that the 'extended family' of the past had shrunk in modern times to smaller nuclear households, Young and Willmott found that the 'wider family' was indeed 'very much alive in the middle of London' (Young & Willmott 1957: 11-12). Their approach to studying the 'wider family' by examining the 'new family of marriage' and other links on both sides – parents, grandparents, siblings, aunts, uncles, nieces, nephews, cousins and in-laws – has proven useful for my own methodological framework.

Research such as that by Bott (1957), Firth et al. (1970), Rosser and Harris (1965) and Young and Willmott (1957) have shown the significant differences between kinship in urban conditions compared with kinship in rural conditions (e.g. Strathern 1981). One example is the difference between the neighbourhood sociability in rural areas that is often based on members of the same families in the village and that of the 'social pockets', which develop in a metropolis such as London, that are not usually composed of kin (Firth et al. 1970: 9). In their cross-class study in urban Swansea, Rosser and Harris also argue that variations in kinship behaviour are as much due to education and class as to formal kinship structure. According to these authors:

While the *elementary* family is a basic structural unit of the society and is thus controlled by a variety of sanctions both legal and diffuse, in relation to the total social system the kinship structure and the organization of *extended families* is not of major and critical importance (1965: 287).

However, because the basic structural framework of Swansea is bound up with the economic system of 'education-professional or vocational training – occupation-employment-income-status-social class' – kinship



in the structure of urban Swansea becomes a 'minor' or 'marginal' matter. This, therefore, makes possible a great deal of individual variation in kinship behaviour (Rosser & Harris 1965: 287-288; for London see also Bott 1957: 221-222; Firth 1956).

I soon part company with these works, however, especially with their illustration of the English kinship system as 'structurally of a relatively simple character' with 'shallow genealogical depth and relatively close lateral boundaries' (Firth et al. 1970: 450; Firth 1956: 18). Unlike the English kinship systems found in Firth's research where individuals did not, on the whole, trace their relatives beyond their grandparents and their second cousins, among the families in my study there were no such narrow genealogical boundaries when reckoning their relatives.

Another key difference between the findings of these studies and my own relates to basic familial structure, which, according to these studies is built around two sides of the family – 'wife's mother-wife-husband-husband's mother' – and 'linked through the marriage to a common set of grandchildren' (Rosser & Harris 1965: 289; Young & Willmott 1957). Within the families in my research, in general, the family structure is built around many sides/strands of parents, and is linked together by a criss-crossing of siblings and grandchildren (see Chapter 4).

On the other hand, the assertion of these findings that the 'socially-accepted weighting' of kin relationships is balanced more on the wife's side of the family – a finding they link to the stress on women's roles and family relationships through the agency of women (Rosser & Harris 1965: 289; Young & Willmott 1957: 44-78) – does also operate on a more complex level among the families in my London research. Among the mixed African-Caribbean and white families, the weighting of the balance of kin relationships is neither straightforwardly on the mother's nor the father's side of the family, but more often on the African-Caribbean side of the family. It is often linked to colour and, sometimes, status difference, which creates conflict and sometimes discontinuities. Thus, the findings from my research suggest that the balance of kin relationships is weighted not so much by gender as by colour and class.

A further difference between these earlier findings and the findings of my research is their suggestion that social support is mainly the province of women. I found that social support is provided by both men and women, depending on the history of the relationships between those in need and those who provide and receive, as well as the type of emotional or material support required and its availability among family members. Thus, we find support being offered by husbands, wives, mothers, brothers, uncles, aunts, grandmothers and grandfathers.

A final key difference between these earlier findings and my own relates to the formal terms in British kinship system that separate parents

and confine siblings to members of the natal family, also restricting grandparents to the two pairs of parents of a person's mother and father (see Firth et al. 1970: 450; Rosser & Harris 1965: 199-200; Young & Willmott 1957). These terms do not operate in the same way among the families in my London research, which have no formal rules about their use. For these features of the kinship system, it is primarily from the Caribbean family literature that the most useful insights can be derived (see e.g. Barrow 1996; Besson 1995, 2002a; Chamberlain 1999; Clarke 1999; Foner 1979; Goulbourne & Chamberlain 2001; Mintz & Price 1992 [1976]; Olwig 1999; R. T. Smith 1988).

Essentially, the earlier studies of kinship and the extended family in Britain reveal modifications of the family structures (in pre-industrial or 'primitive' societies) in response to changes in an industrial environment. However, the framework was limited largely to *static* approaches, with data drawn primarily from genealogically close and personal relationships, with an emphasis on frequency of contacts, and exchange of aid among a web of 'traditional' extended family members (see Firth 1956; Young & Willmott 1957). Rosser and Harris' study entitled *The Family and Social Change in Swansea* (1965), a parallel and comparative study to Young and Willmott's of Bethnal Green, offers further insight into the modification of the kinship group in response to industrialisation and urbanisation. They concluded that in Swansea, a region far less compact and more heterogeneous in social composition – in terms of history, tradition, topography and, to some extent, language – the extended family 'still performs most of those primarily domestic functions of help in crisis which was characteristic of the extended family found in Bethnal Green' (Rosser & Harris 1965: 292).

These suggestions are similar to some of my own findings. However, the families in my research were responding not only to industrialisation and urbanisation, but also to migration, racism and mixed sociability. Thus, although these works have given me some general insights into possible approaches for analysing my research data, they have not proved sufficient in their theoretical tools to address the main themes that emerged among these mixed London families.

### **More recent studies of British kinship**

With very few exceptions (e.g. Simpson 1998), anthropological work on British kinship is still largely lacking. Most of the material from which information on the practice of extended kin relationships can be gleaned has continued to be sociological, working mainly on 'the family' (e.g. Rapoport et al. 1982; Brannen & O'Brien 1995; Smart & Neale 1999; Phillipson et al. 2001; Phillipson et al. 2003; Finch 1989; Finch

& Mason 1993, 2000; Mansfield 1988; Barnes et al. 1998). These works cover themes such as family and social change, marital relationships, divorce, family support of the elderly, women in migrant Bangladeshi families, family obligations, inheritance and step-parenting.

What these more recent studies reveal is that among the current British population, there is a greater diversity of experience than in the past of family and kinship arrangements due to current patterns of marriage and divorce and other types of couple relationships (see Simpson 1998; Smart & Neale 1999). These studies also show that there is wide variation when it comes to who gets included in kin groups, based on the type of interpersonal and practical exchanges involved and how they change over time and generations. These studies also argue that among the British population, there is a widespread conception that 'my family' means more than co-residential domestic arrangements (Finch & Mason 2000: 6). Children now have a more complex and wider combination of parents and step-parents, several sets of grandparents, siblings and other kin. Plus, many adults and children are linked by a variety of in-law relationships (see Simpson 1998; Smart & Neale 1999; Weeks et al. 1999a, 1999b). Thus, even with the nuclear family, co-residence can no longer be regarded as a universal characteristic, partly due to divorce and subsequent repartnering arrangements. Simpson (1998), for example, illustrates how divorce and remarriage are transforming families in Britain. Simpson dubbed the prolonged and complex social arrangements following divorce and remarriage the 'unclear family', as opposed to the idealised 'nuclear' family of the political, bureaucratic and intellectual imagination in Thatcherite Britain (Simpson 1998: vii-xii). Smart and Neale (1999: 181) state that the policy on family law at the end of the 1980s and early 1990s, with its desired aim to return family and married life to a 'stable nuclear ideal', resulted instead in people formulating their own family patterns, in ways that may:

Disperse the biological family across households and marriages/cohabitations. It may also generate links between grandparents and grandchildren which are no longer anchored in the marriage of the parents, but which can survive various transformations in those parents' relationships because they are forged directly with the grandchildren rather than resting on the longevity of marriage. Moreover, in future these grandparents are themselves more likely to be divorced and even repartnered, introducing the possibility – for want of a better word – of *step*-grandparents.

What these more recent studies show generally is that, now more than before, people are inclined to make conscious decisions about who counts as 'my family' and for what purpose (Finch & Mason 2000: 7).

As Simpson (1998) and Smart and Neal (1999) show, families have not been destroyed to the degree that had been anticipated and generally assumed. Rather, they have been created and recreated to suit their changing circumstances.

### **Caribbean families in Britain**

Although Caribbean families and kinship have been reshaped in Britain (Goulbourne & Chamberlain 2001), there has been little research on these changes. But as Finch (1989: 52) points out, with regards to the paucity of research on family and kinship variation in Britain as a consequence of ethnic variation:

Researchers working in the 1950s perhaps could be forgiven for not recognizing the importance of ethnicity in family relations, since Britain was a more monolithic society in ethnic terms than it became subsequently. We can now see that ethnicity is an important source of variation in individual experience and no studies of family life can afford to ignore it.

Thus, the different cultural traditions represented in Britain map onto kin relationships in significant ways, even if they are little understood. Therefore, the general notion of 'the family' as consisting primarily of its nuclear core never made any sense if it was intended to include British citizens whose cultural roots are in the Indian subcontinent, Africa or the Caribbean (Finch & Mason 2000: 6; see also Goulbourne 1999).

Discussions about the problems faced by Caribbean communities in Britain – for example, in education, employment, housing, or with the police – are nearly always informed by general assumptions about their family and kinship patterns. Yet, family life, kinship systems and living arrangements have rarely been the particular focus of either academic inquiry or policy discussions (Goulbourne 2001a: 25). Nearly all the assumptions and generalisations with regards to the 'breakdown' of the Caribbean family in Britain are based on census data and surveys. Thus, from these sources, it has been argued that the absence of a nuclear unit and the high incidence of single-parent households result from migration, which ruptured the generational family links and kinship arrangements, and disrupted patterns of socialisation and stability, 'leaving the Caribbean family disorientated and directionless' (Chamberlain 2001a: 40). This situation, in popular views, has been further compounded by state dependency (see Dench 1992). However, the census surveys use 'households' as their unit of measurement,

assuming that households equate families. What census data cannot show is the persistence of Caribbean family patterns and living arrangements in Britain (see Bauer & Thompson 2006; Chamberlain 2001a; Goulbourne 2001b). The census could never reveal the complex kinship patterns among Caribbean families in Britain that are rooted in extensive ties of reciprocity and mutual aid that have developed alongside the supposed 'pathological' features of the 'single-parent', 'female-headed' households, 'unstable' and non-legal unions (Smith 2001: 56). Anthropological studies in the Caribbean and the United States have shown the pragmatism and viability of these complex kinship systems, as well as their functional appropriateness in response to conditions of unstable economic conditions (see Driver 1982; R.T. Smith 1956; Stack 1974).

Moreover, recent sociological research on changing white British families is revealing some close parallels with Caribbean families in Britain, although there has been little attempt at comparison between the two groups. Although the Caribbean migrant community experienced increased rates of formal marriage in the 1960s 'when they joined in the British celebration of the nuclear family as the universal and ideal model' (Goulbourne 2001b: 240), among their offspring and the younger generations this is not the case. They have chosen family patterns and living arrangements that are typical of families in the Caribbean, and becoming typical in Britain (see Mansfield 2006). Thus, some social scientists question whether the 'new minority are adopting the values of the indigenous majority population', or instead, whether we have a situation in which the patterns of Caribbean families and living arrangements are 'becoming the generalised patterns for the majority community' (Goulbourne 2001b: 235-236). Mansfield (2006), in her research on marriage and family life among white British families, emphasises how family life in Britain has been transformed since the 1970s. While the numbers of marriages have halved, divorces have doubled and extramarital births quadrupled. The common sequence of family formation as it exists today is: 'cohabitation-marriage-parent-hood', with other emerging sequences such as: 'cohabitation-parent-hood-marriage' and, most recently, 'parenthood-cohabitation-marriage' (ibid.: 65).

Additionally, in her cross-cultural research on 'mother-headed families' Burns (1995) shows that while there is a high rate of single motherhood among African-Caribbeans in the UK, the great majority of single mothers are in fact white (1995: 159). Furthermore, with regards to generalisations about lone Caribbean mothers and state dependency (see Dench 1992), it has been shown that while half of Caribbean mothers in Britain are single and never married, many of them receive help from the children's fathers. Also, because Caribbean mothers are

more likely to be working than other lone parents, among all lone parents, they are the least likely to be poor (Platt 2002: 86). This relates to the traditional economic independence of women in Caribbean families (see Barrow 1996; Besson 2002a; Bauer & Thompson 2006).

As with the lack of research on Caribbean family life in Britain, with the exception of Benson's (1981) work on couple families 39 years ago, so too has there been a lack of research on mixed African-Caribbean and white British couples or extended families in Britain. The British media and advertising campaigns are highly peppered with mixed-heritage couples, which is a reflection of the growing phenomenon. Mixed-heritage families, like same-heritage families, are sites of support and strength as well as conflict and pains. Yet they have escaped the interest of qualitative kinship researchers, thus left as the subject only of general public assumptions based on stereotypes and prejudices. I believe that they fully warrant social science inquiry. Research on these families could add a significant new perspective to our knowledge of British kinship and encourage debates about it.

### **Key supporting literature**

In my attempt to analyse the ethnographic data of the lives of the families in this research in relation to the existing literature on British family and kinship studies, I arrived at a near roadblock. Although these mixed families are British families – London families – they have been ignored by British kinship studies. Furthermore, the themes that emerged as central to my understanding of their relationships, such as family history, mixing, belonging, fluidity, continuity and change, are largely lacking from the previous studies of British kinship. Hence, with their predominant research focus on households and genealogy, the previous studies proved largely unhelpful for the analysis of my research families.

One central theme running through this book concerns the ongoing struggles encountered by family members and the strategies that they have had to devise to find suitable ways of conducting their lives. Devising coping strategies in order to function within families is not unique to these families. What is different for most of them is that from the start – beginning with the couples – conflicts, negotiations, adaptation and accommodation become continuing aspects of their relationships. This is due partly to individual personalities and choices, but also to the different cultural expectations and behaviours that individuals bring into their family relationships – differences that are exaggerated when partners come from radically different social and cultural environments. This is a key issue that is missing in much of the

literature, especially from the earlier anthropological studies. More recently, however, it has been usefully added by a few social scientists (see Finch & Mason 2000; Smart & Neal 1999; Simpson 1998).

In these dynamic, intricate kin networks among mixed African-Caribbean and white British families in London, five themes emerge in the chapters that follow that are relevant to kin relatedness. These themes include: the significance of *history and mixed sociability in the process of kinship*, *the centrality of women and children in doing kinship*, the importance of *family stories and narratives in understanding kinship*, *ideas about kinship and relatedness* that are untypical to British kinship and, finally – what I believe is this book's overarching theme – *creolisation*. Creolisation springs from the long transgenerational history of mixing and change in culture and kinship between Britain and the Caribbean. What follows is an explanation of each theme, in terms of its usefulness for understanding family relatedness, and the more relevant theoretical writings that have provided insights.

## History and the process of kinship

Family and kinship networks do not just develop in particular social circumstances, but also in historical periods and under historical conditions. Thus, understanding the process of kinship among mixed African-Caribbean and white British families in London, requires an understanding of the process of mixed sociability over time and across generations. As Chapter 1 illustrates, history also helps to map the processes of incorporation, negotiation and accommodation in the London context. Within these families, history helps to explain the diversity of family practices across generations as a result of the ways in which negotiations are reached not only because of family influences, but also due to influences from the wider social forces. It is also by looking at the history of relationships, as told by family members, that we understand the discontinuities and continuities in family relationships.

### *Kinship and generations*

In looking at history to explain the process of kinship among mixed African-Caribbean and white British extended families in London, I have found Carsten's (1997) work on Malay kinship particularly helpful. Carsten has combined history with ethnography to show that kinship is a temporal process. She has shown how, for many people, time and history are understood in the expressions of kinship and ideas about relatedness (Carsten 1997: 13-14). Hence, Carsten shows that Malay kinship

is a process that emerges through time, through the process of giving and receiving food.

Kinship for the families in London is a complex historical process. Their family histories show that change for them comes about through ongoing cycles of births, complex lateral sibling connections and affinal links, separations, divorce, illness and death, not to mention the influence and the impact of the wider social forces. Throughout the book, and particularly in Chapters 3 and 5, most of the material discussed comes from the perspective of individual family members learned from older generations. In effect, the material presented is an account of 'the history of their kinship' (ibid.: 13). Thus, in Chapter 5, for example, it is largely through a historical analysis that we understand the practices and attitudes as they have evolved among members of Verna's family.

With regards to individuals' sense of belonging and their membership or position in their families, I have also found Gow's concept of 'the temporal processes of kinship' (1991: 259-270) useful. For the people in my research, the time dimension of kinship and their membership in the kinship group – and in the wider society – also relates to the time dimension of history (see also Edwards 2008). Throughout the book, we see how individuals use various strategies to negotiate their own and other's positions within their kin group. The status or position a person holds or is given within her or his family and kin group is highly contingent upon past acts of caring from childhood to adulthood. In other words, an individual's position in a family is highly dependent upon a process involving past experiences of care given, as well as of mutual exchanges of help and support. Hence, we find throughout the following chapters, that even biological parents, sibling and other blood relatives could become marginal to the kinship group, depending on the type and quality of past relationships (see also Bauer & Thompson 2006; Bourdieu 1977, 1990; Finch 1989).

#### *Incorporation, negotiation, accommodation and innovation*

Historical and generational frameworks also proved useful in understanding the processes of incorporation, accommodation, adaptation, negotiation and innovation within the families in my research. As Finch points out, negotiations between members of the same family regarding the types of support to be provided draws upon the history of relationships and commitments in that particular family (Finch 1989: 201). I show throughout the book how current forms of relationship between individuals in a family reflect the past history of the relationship between those individuals. For example, where adult children have a poor relationship with their own parents, the explanations given by them often relate to their own childhood experiences (see also Firth et



al. 1970: 399-407). A particular example can be found in Chapter 5, where the poor relationship between Lionel and his father, Boysie, affected negotiations regarding the provision of support for Boysie in his old age. From Lionel's perspective, Boysie's track record as an unsupportive father throughout his life meant he did not feel any sense of moral obligation towards him in his old age. Because no dynamic of reciprocity had been established between them, no reciprocal gift was required.

The historical and generational approach also helps us examine how the roles and positions within the family are negotiated, and to see how they vary between generations and individual family members. As some authors have pointed out, (see Chamberlain 2001b; R. T. Smith 2001), there is little historical support for the notion of 'traditional' family values. Among the families in my research, this notion is further complicated by the variety of family forms that individual members bring to their particular family. Thus, in exploring traditions and practices across generations, we find in Chapter 4 that the 'traditional' formal sit-down Sunday dinner that was an aspect of the family of Gobi's Jamaican partner Randall has continued in Gobi's home, though the formal aspect of everyone eating together at the table has gone. Instead, the food remains on the stove, so family members can help themselves as they come in at various times throughout the afternoon. Using history and generation as conceptual tools can therefore help us more clearly achieve an understanding of family practices in the current context.

### *Discontinuities and continuities of family relationships*

Employing an historical framework for analysis also helps to explain the discontinuities and continuities in family relationships that are part of the process of kinship. Kinship is not something that reproduces itself identically, but 'was created, it exists in a specific form now, and it has a future' (Gow 1991: 199). Discontinuities and continuities of relationships among kin members in the London families are outcomes of ongoing processes with many factors involved. Some of the causes of rupture and distancing are, in order of significance: colour prejudice/racism, social-class difference, separation and divorce and death. As we have seen in Chapter 1, racism was an issue for many families. Because of racism, many of the British partners (mostly women of the mixed couples who met between the 1950s and the 1970s) found themselves cut off from their families of origin. For some, the difficult situation was intensified by the arrival of children, so even the more liberal would ask: 'What will happen to the children?' 'How will the children fit into society?' Alongside such questions there were also assertions such as: 'They will never fit in'. Or: 'They are bound to feel displaced in

society, because they are neither black nor white' (see also Benson 1981). As the following chapters illustrate (Chapters 6 and 7, in particular), racism still operates as a divisive factor in family relationships, albeit different in kind and in intensity, reflecting increased social interactions over time and between generations, and a blurring of cultural boundaries (see what follows on 'creolisation').

Although issues such as class difference, family conflict, separation, divorce and death have been identified as general causes of family disruption and break up, what is striking among the families is how rarely these issues result in discontinuities. Instead, faced with separations, divorces and deaths, family relationships most often continue, based on individuals' sense of shared histories and, indeed, shared expectations for the future. A primary explanation people give for continuities in their families – especially after separation or divorce – is that it is 'for the sake of the children'. Lester, a 55-year-old Jamaican migrant, speaks for many: 'The relationship hasn't ended, even though the fix of legal marriage has ended. We have our children and grandchildren between us, and they keep us all going together still'. However, it is not only parental relationships that continue after separation and divorce, but also relationships in the wider kin network. This is so, because the web of extended familial relationships that people develop over time are not easily erased. As one white woman puts it, 'I have come to embrace my West Indian family and culture, and with the gifts of love and support we have given each other over the years, it is very difficult for me to close the door on that'.

In the main, for these families continuity is about shared experiences and hopes over time, and their expectations for the future. And this is also an ongoing process of evaluating and reevaluating relationships (see Chapters 3, 4 and 5). Finch refers to this process as 'working it out' (1989: 179-211). Her work is insightful with regard to negotiating family commitments over time. However, from an anthropological perspective, in dealing with the questions of which kin relationships continue and which do not, it is with Simpson's (1998) work that I align myself. In his ethnographic account of kinship relationships after separation and divorce, Simpson explores a significant area of family relationships that is very central to my research. That is, the question of what happens when people separate and divorce and move into a 'new and alternative pattern of domestic and personal life, with relationships based on complex and convoluted patterns of inter-personal commitment, dependency and exchange' (ibid. 1998: x). As already mentioned, Simpson refers to the complex social arrangements following divorce and remarriage as the 'unclear' family. He argues that, although the domestic and social arrangements evolving after divorce involve the mingling of positive and negative sentiments expressed between husbands and wives

and other family members might be complex and unclear, 'they are still expressions of human kinship and are therefore of primary anthropological concern' (ibid.: xi). Simpson's argument is some distance away from the classical structural-functionalist emphasis on relationships that work.

Simpson's particular relevance for my work is that, instead of viewing family and kinship relationships as collapsing after the couple separates, he examines the ongoing transformation that kin relationships undergo to fit the existing social and economic situations of all involved. Simpson points to the language used in popular discourse (political and sociological) such as 'lone' or 'single parent' (often mother), 'second family' and 'absent father', which tend to emphasise the rupture and divisiveness, while masking the ways in which people retain connections after the couple separate (Simpson 1998: 33). From an anthropological perspective, the dominant paradigms of kinship and family in Western society, and adopted by the discipline, have a limited conceptual and analytical vocabulary with which to consider these continuities.

This book examines kin relationships as an ongoing process – despite circumstances such as family ruptures caused by migration, conflict and ostracism due to colour prejudice and crises resulting from separation, divorce, illness and death – to uncover some of the more enduring aspects of individual and family relationships. Chapters 4 and 5 provide good examples of continuities after separation and divorce. What is particularly striking is how much effort the women (Gobi and Chantal) invest into maintaining family relationships primarily, according to them, 'for the children'. This leads us to the second theme central to the book: the significance of women and children in forming and maintaining kinship links.

### **The centrality of women and children in doing kinship**

The earlier literature on British kinship offers some ideas about the centrality of women in doing kinship. Young and Willmott (1957), for example, refer to the 'mother-centred kinship system' whereby the extended family was organised 'by women and for women', and became the 'trade union' for women after they become married (Young & Willmott 1957: 189). The close relationship between mother and daughter, and the closer kin ties between the wife and her family of origin, was protection against the men who either died sooner than their wives, were often unemployed or kept their wives short of money even when employed. Thus, the mother-daughter relationship was based on mutual aid and support, with mothers giving help in the care and responsibility of children and

daughters reciprocating when their mothers were left widowed or old and in need of care. Rosser and Harris' (1965) comparative Swansea study also found that the wife's family of origin was dominant, highlighting the emphasis on women's role in the family and kin relationships. On the whole, these studies found that 'mum' (typically the wife's mother) was the person who 'holds the family together, "the dominant centre of the web of kinship"', with a tendency for the married daughter to live with her mother or close to her (Rosser & Harris 1965: vi).

My study also shows a strong relationship between mothers and daughters. However, mothers are not the only ones that hold the family together or form the dominant 'web of kinship'. I found mothers, but also daughters, grandmothers, wives, former wives and aunts playing key roles in doing kinship (and also some men, but to a lesser degree).

Chapters 3, 4 and 5 illustrate vivid examples of women across generations putting great effort into creating and 'keeping the family going'. In Chapter 3, in particular, we find how Polly's instrumentality has generated an ongoing kinship network that includes her ex-husband, his 'outside' child and the child's mother. Furthermore, although family relationships with Polly's ex-husband Geoff had been discontinued after a bitter divorce, it was Polly's daughter Anna whose strategic renegotiations restored Geoff's position within the family. In Chapter 4 the key figures in doing kinship are Gobi herself, her ex-partner Randall's mother Angela and Gobi's adopted daughter Christa. Another striking feature among Gobi's family is the manner in which family members relate to one another equally, regardless of whether or not they are biologically related. Within the family, we find three sets of grandparents with whom the children relate equally, calling them 'Grandma', 'Granny' or 'Granddad'. To the children, Gobi is 'Mum' and, to each other, they are 'sister' and 'brother'.

The significance of children and siblings in creating the links between families have been ignored or underemphasised in British kinship studies. In the limited space given to siblings, the emphasis has been placed on *gender difference* in the *frequency of contact* between siblings, between siblings and their mother and their mother's siblings. Thus, they show the influence of mothers in the frequency of contact between siblings – siblings see each other because they see mum, and daughters see mum more often than sons see her (Young & Willmott 1957: 77); men have poorer relations with siblings than women do (Firth et al. 1970: 431); the higher frequency of contact with mother's siblings shows the stress on relationships through women (Rosser & Harris 1965: 221-222). Essentially, what these studies show is a female and maternal bias at various genealogical levels.

A notable exception to these British kinship studies is Simpson's (1998: 36) emphasis on children, in his analysis of continuities after

divorce and separation. Simpson shows that, where there are children from a marriage, after divorce, notions of continuity, connectedness and extension become fundamental to kinship as well as 'to the relational context through which people identify themselves'. This is so not only because workable relationships become crucial between parents and their children, but because preserving some continuity of the sibling group is also essential. Hence, the 'family', as it emerges after divorce, 'is complex, with children and resources linking households across space and time, in ways that render the identification of family with a single discrete household wholly misleading' (ibid.: 31).

Simpson shows that where children are concerned, relationships after divorce are rarely brought to an absolute end. Instead, they roll forward with considerable momentum for many years, constituting an important part of the complex structures of post-divorce family relationships (ibid.: 151). For example, in my London study, after Marva and Troy divorced, relationships with the children continued as Troy moved between households. Troy later partnered with another woman, Lisa, and they had two children. When Lisa went to the hospital to deliver her second child, it was Marva who took the first child into her home and cared for her until Lisa was well enough. Additionally, although Marva does not regularly visit Troy and Lisa in their home, she has active relationships with both of them and their younger children.

Carsten's (1997) illustrations of Malay 'relatedness' effectively demonstrate what is significant to Malays as opposed to what would be significant to Western kinship with its emphasis on genealogy. However, her analysis of Malay kinship, which takes the emphasis beyond biological kinship to include 'social kinship', also demonstrates a flexibility of kin relationships that I found among the families in my study. Similarly, her comments regarding the prominence of women and children resonate with my own findings. In Pulau Langkawi, Carsten argues that women's activities are at the heart of the process of incorporation among kin and that siblingship is the 'core of kinship' rather than filiation (ibid.: 25). In Langkawi, siblingship is the most elaborated relation, with all other relations said to derive from sibling relations, and 'women and sibling sets are intimately bound up with each other and with the way kinship is lived and conceptualized' (Carsten 2004: 13-14). Among the London families, it is primarily through the sibling sets that kinship links are formed, and it is the women – young and old and across generations – who actively maintain kinship links.

The complex and intricate forms of relatedness among these London families in my research could never be adequately understood from observations alone. Furthermore, understanding relatedness from an historical and generational perspective is only possible when complemented by the life story narratives people tell. Hence, a third theme

– life stories and narratives – became central for analysis of their family lives.

### **Family stories and narratives in understanding kinship**

Simpson notes that the complex and sometimes problematic character of post-divorce family relationships are marked by the presence and absence of significant others. Thus, the life stories and narratives people construct on past, present and future events are important in facilitating our understanding of family and kinship relationships. As Simpson notes (1998: 151): ‘Parties demonstrate the sense they make of these relationships through the stories they tell, that is, narratives which locate others in relation to self’. For the mixed African-Caribbean and white British families in my London study, kinship is largely understood through a history and narrative; their memories of past events, family practices and relationships, experiences of joys and pains make up their story of family and relationships.

Thus, although participant observation is a key element in fieldwork, oral narratives are also important, even though the relationship between these two elements is not always clear. Observing what people do provides us with crucial evidence but, by listening to people’s narratives and explanations of their family histories, we can gain an extra dimension of understanding. This is because people’s actions in the present look not only to the future, but also to their own experience of the past. This helps to shape what they do or avoid doing in the present (Thompson 2000). Furthermore, anthropologists have, for some time, pointed to the significance of ‘an ethnography with time and transformation built into it’ as ‘a distinct way of knowing the anthropological object’ (Sahlins 1994: 377). Chapter 3 provides a good example of this argument. Here we follow four generations of the Smith family, from the early 1950s to the present. We see the transformations within the kin network, not only with regards to their relations to each other, but also in terms of their relationships with people in the wider society, as a consequence of changing social and political circumstances over time.

Collecting life stories across three generations made it possible to construct a profile of family life and patterns of behaviour, with the memory of the older generations extending across time and space. It was through the transgenerational life stories that knowledge of family organisations and living arrangements were gained, as well as how attitudes, behaviour and practices are negotiated and modified across generations. In Jess’ family, for example, it was through her children’s narratives that I was able to uncover the important genealogical link with Jess’ grandchild that she failed to acknowledge, due to her ‘respectable’

and contradictory attitude regarding marriage out of wedlock. In other words, it was through 'the history of their kinship' (Carsten 1997: 13) that I was able to understand the ideas, dynamics and forms of relatedness people constructed within their kinship networks.

For example, in chapter 5, my first experience with members of Verna and Ken's extended family at the birthday dinner event made me aware that the real-life experiences and memories of people cannot be easily omitted, edited or erased. It was only after hearing the family stories that I understood the enduring presence of Verna's mother Chantal who had died four years earlier, and the significant impact and influence she still had on family relationships. Through the narratives of her children and other members in her family, Chantal's voice is heard.

It is also through narratives and life stories that individuals convey their sense of belonging and right to recognition in a society that they have lived most of their lives (Besson & Olwig 2005). In Chapter 7, for example, mixed-heritage individuals speak about their instrumentality in constructing their own ethnic identity for the census. Through their own actions they resist the categories intended to subsume them within an institutionally imposed marginal ethnic group to which they do not feel they belong.

The complexities of using oral narratives (and other oral sources) in qualitative research have been documented by many researchers (see e. g. Finnegan & Drake 1994; Samuel & Thompson 1990; Thompson 2000). But along with the strengths of this approach there are also limitations. Besides the time-consuming aspect of audio-recording and transcribing long interviews, there is always the problem of memory. The interview is a dialogue between the past and the present. The process of remembering is also a dialectical process, incorporating current questions and concerns as well as the act of remembering into the memory. This process of remembering is entwined with hopes, dreams, fears and past regrets that are further entangled with current recollections (Chamberlain 2006: 13). Consequently, in telling and retelling family stories, people often misremember or forget names, dates and events. They are selective in their accounts, depending on how they want to present – or preserve – their family history, or perhaps on what they believe the interviewer wants to hear. Additionally, as some researchers have pointed out (see Abrahams 1985; Bornat 1989; Samuel & Thompson 1990), people's memories are in part moulded over time through myths and images and by the ideologies and conventions not only within their families, but also within the wider society. Therefore 'our narrative models, drawn from the culture we live in, shape even our own first-hand experience and expression', and in order 'to understand who we are and what we have done we "narrate our lives"

following out those models' (Finnegan 1994: 121). Thus, although oral narratives are important for understanding people's life experiences, in light of the complexities of memory, this approach needs to be employed with caution.

Caution need not restrict interpretation, however, both because, to a large extent, people do remember reasonably well. And even if their memory is different at different times in their lives and in different contexts, this can in itself offer clues to how individuals see themselves in relation to others in their families and the society at large. Thus, the multiplicities, discrepancies and unpredictability of memory could prove effective in analysis, as memories also require interpretation if their full richness is to be exploited (Chamberlain 2001b: 119; Portelli 1991). In attempting to deal with the limitations posed by memory, I employed several strategies, such as interviewing family members across generations and paying careful attention to casual conversations – especially when a number of relatives were gathered together. I also asked to see as many family photographs as possible; this approach not only brought missing family members visually into the kinship framework, but also contextualised past family events (see Bouquet 2001; Sontag 1997).

### Ideas about kinship and relatedness

In recent years, anthropologists have used many conceptual perspectives to analyse family traditions and relationships, and among them the concept of 'relatedness' has been especially prominent. Relatedness as a conceptual tool shifts the analysis of family and kinship studies away from genealogical connections (biology and nature) as the central definition of kinship, to a more flexible approach that includes the 'local meanings and symbols' (Schweitzer 2000: 6-7) of being related in particular cultural contexts (Bouquet 1993; Carsten 2000; Strathern 1992a, 1992b). While these anthropologists are not denying biology as an aspect in the study of kinship, they argue that, 'biology alone is insufficient for a comprehensive understanding of what kinship *is* and *does*' (Schweitzer 2000: 16). In other words, the concept of relatedness enquires locally into what particular terms, practices and rules mean to people. It offers new understandings into their own ideas or constructions of family relatedness, which are not necessarily based on the recognition of genealogical connections (Carsten 2000; Schweitzer 2000).

Among kinship theorists, Schneider (1968, 1984) has been influential in steering kinship studies away from genealogical relationships toward a more cultural analysis. In *After Nature*, Strathern (1992a), using



Schneider's kinship model as a point of departure, argues that in Britain, with the effects of technological developments in reproduction, nature alone does not work for the analysis of families and kinship. Hence, she calls for 'a new conceptualization of the ground for knowledge' to explain the 'modern cycle' (Strathern 1992a: 195). Bouquet (1993) views relatedness as a 'concept which allows for different nuances' and which 'does not presuppose that genealogical relations are necessarily the most important' (Bouquet 1993: 157). Carsten's (2000) use of the concept shifts kinship studies 'away from a pre-given analytic opposition between the biological [resulting from sexual reproduction] and the social [as in adoption and fostering arrangements] on which much anthropological study of kinship has rested' (Carsten 2000: 4), to the 'lived experience of relatedness in local contexts' (*ibid.*: 1). Furthermore, Carsten (1997) rejects Schneider's (1984) notion of distinguishing or separating biological kinship from social kinship on the grounds that kinship defined in these terms cannot be applied cross-culturally. Carsten's (1997: 290) view is as follows:

Instead of rejecting kinship as such, I suggest that we would do better to ask: how do the people we study define and construct their notions of relatedness and what values and meaning do they give them? If we accept that both the definition and the meaning of kinship are culturally variable, then we certainly must reject a universal definition of kinship in terms of procreation. But this does not mean that we cannot compare both how people conceive of relatedness and the meaning they attribute it in different cultures. It seems to me that if we are to reject kinship in the sense which Schneider criticizes, then we would do better to adopt a term to characterize the relatedness which people act and feel. I would call this kinship.

New kinship studies exploring gay and lesbian kinship (Weston 1991), adoption (Modell 1994), 'house societies' (Carsten 1997), kinship resulting from reproductive technologies (Strathern 1992b), surrogacy (Ragone 1994) and step-families (Gorell Barnes, Thompson, Daniel & Burchardt 1998) have explored 'cultures of relatedness' beyond the traditional biological representation of kinship (Carsten 2000) with an attempt to evaluate 'the role of non-biological means in the reproduction of ourselves' (Schweitzer 2000: 8). As with these new kinship studies, my research on mixed-heritage African-Caribbean and white British families also challenges kinship studies that view sexual procreation or shared substance as the central symbol of kinship (Schneider 1980 [1968], 1984). However, as Schweitzer points out, while it has become evident that biology alone is insufficient for a comprehensive

understanding of what kinship *is* and *does*, it is equally hard to maintain that kinship has nothing to do with biology and procreation' (Schweitzer 2000: 16). My research on mixed-heritage families also supports this view.

The findings from my study suggest that mixed-heritage families cannot be understood without including their families of origin. The vocabulary people used when describing and evaluating their kin relations made this evident. Practices such as the adoption of children and grandchildren, precisely because of 'blood ties', also confirms this. However, what was also clear was that family and kinship were not limited to 'blood relatives', but also extended into a universe of relatives through fostering, adoption of non-blood children and other non-biological and fictive kin relations. For some people, these developed into closer kinship bonds than genealogical ties. Family to them were individuals they described as their 'support network', among whom they shared emotional, financial and material resources for support and maintenance of their family/kinship network.

Anthropological research undertaken since the 1980s has been most noteworthy for a conceptual shift, an attempt to combine 'biological' and 'social' relationships and other new constructions of kinship that are occurring through a process of choice. Kinship and relatedness are described in terms of 'indigenous statements and practices' (Carsten 2000: 3). Furthermore, the effects of the new reproductive technologies – surrogate motherhood, artificial insemination, in vitro fertilization, etc. – have challenged long-standing Anglo-American concepts of kinship (Stone 2004: 332). With reference to British and European kinship, Strathern argues that the effects of the new reproductive technologies and the introduction of consumer choice to the areas of human reproduction in which such choice was not applied in the past has shifted the perception of kinship from 'nature' to a perception of kinship as social construction, 'personal preference' and as 'choice' (Strathern 1992b: 31-43).

Nevertheless the debate over the problem of defining 'kinship' – and how to make that definition universal – continues. There are some works that I have found helpful. Ishwaran and Piddington's edited volume, *Kinship and Geographical Mobility* (1965), has provided insights into kinship relationships over geographical distances due to migration, urbanisation, industrialisation and acculturation. As with a handful of recent works to have broadened the long-standing anthropological understanding of kinship (see e.g. Besson 1995; Black 1995; Carsten 1997, 2000, 2004; Finch & Mason 2000; Strathern 1992a, 1992b; Weston 1991; Simpson 1998), my research also challenges the traditional views of kinship, as it requires analysis that reflects what patterns of behaviour and ideas about relatedness mean to people on their own terms,

based on their own particular experiences, 'rather than models derived from the analysis of very different cultures' (Carsten 1997: 27).

It is Carsten, building on and advancing Schneider's arguments, whom I have found most useful in suggesting conceptual tools for my analysis. In *Cultures of Relatedness*, Carsten's (2000) use of the concept of 'relatedness' – although open to criticisms (see e.g. Holy 1996: 167-169) – shifts kinship studies 'away from a pre-given analytic opposition between the biological and the social on which much anthropological study of kinship has rested' (Carsten 2000: 4), to the 'lived experience of relatedness in local contexts' (ibid.: 1). This alternative approach freed her to explore Malay notions of 'relatedness'. So instead of asking if Malays have kinship by the traditional anthropological definition of kinship, she asks, how do Malays construct and define their notions of relatedness, and what value and meaning do they give to them? (ibid.: 322). Carsten suggests that this broader, more open and flexible category of 'relatedness' would encourage an anthropological redefinition of 'kinship' that was less bound by analytic assumptions and more open to indigenous diversity (Carsten 1997: 285). In response to criticisms that broadening the concept from 'kinship' to 'relatedness' would obfuscate the boundaries and make it difficult to distinguish 'kin' from friends or neighbours, Carsten admits that broadening the concept does not solve the problem. Instead, the concept of relatedness has effectively enabled her to:

suspend one set of assumptions, and to bracket off a particular nexus of problems, in order to frame questions differently. 'Relatedness' makes possible comparisons between Inupiat and English or Nuer ways of being related without relying on an arbitrary distinction between biology and culture, and without presupposing what constitutes kinship. (Carsten 2000: 5)

The problem I faced in describing kinship among the people in my London study is that the dominant social science theoretical models of kinship do not correspond with their kinship notions and practice. As with Malay kinship, among the London families, relatedness is derived both from reproduction and social activities, and separating the two categories is not something people do when they speak about their kin. They define their forms of relatedness in terms of biology (though prone to selectivity) and also in terms of their history and experience of kinship practice (see Bourdieu 1997, 1990).

Carsten argues that kinship is not a fixed state, but is a process of becoming. This process involves the practices of living together, eating together, fostering and marriage, and these activities, particularly the sharing of food, create and strengthen the substance – namely, blood –

through which people conceive their notions of relatedness. Unlike the Western conception of 'blood' as something one is born with, for Malays it is a substance that is 'continuously produced and transformed from food that is eaten' (Carsten 2004: 319). Essentially, Carsten argues that:

Kinship is not a lifeless and pre-given force which in some mysterious way determines the form of people's relations with each other. On the contrary, it consists of the many small actions, exchanges, friendships and enmities that people themselves create in their everyday lives. For most people it is perhaps the heart of their creativity. But the content of these relations is not only continuously created anew, it is also shaped by long-term political processes. And this has also involved rethinking what kinship is – from a different angle. (Carsten 1997: 23)

Carsten's point relates very closely to my data, especially in reference to creativity, which is relevant to the lives of the people in the study – and of particular relevance to the women as key in doing kinship. Thus, it is primarily with this approach to kinship that I align myself and move forward in the chapters that follow, exploring the relatedness that people in my London research *act, feel* and *speak* about.

A large part of the research aim is to answer questions such as: who is family? And, on what bases are family recognised? From these questions, I hope to gain insight and understanding into what family means to these mixed-heritage families. Hence, I believe that employing Carsten's (1997, 2000, 2004) concept of relatedness as an analytic tool could prove useful. However, the concept does not fully capture the complexities involved in the experiences of the families in my research. For example, it does not answer other questions such as: under what historical conditions do people come together to form mixed-heritage families? In the process of creating their families, what strategies do they develop to overcome racism and other societal and familial constraints? How are they maintained, given their experiences of ongoing struggles/conflicts? How are they recreated/reproduced? Essentially, my research requires a more comprehensive approach that evaluates the ongoing *process* of kinship among these families. A process that illuminates not only mobility and mixing (as in hybridity), but illuminates also the history, cultural conflict, rupture, trauma, racism/violence, structural inequalities, resistance and the survival strategies of adaptation and accommodation. Ultimately resulting in a dynamic and innovative "type" which is recognised as "belonging to the locale" but continuing to interact with new influences' (Allen 2002 cited in Sheller 2003: 276). Essentially, my study required a conceptual framework that would

help explain the historical and cultural dimensions from which these individuals 'forged' their complex and dynamic family formations and interrelationships.

### Ideas about creolisation

Although there are various theories regarding the concept of creolisation (see e.g. Brathwaite 1971; Burton 1997; Bolland 2002; Collier & Fleischman 2003; Mintz 1996; Sheller 2003; Trouillot 1998), I believe that the concept taken in the main captures the ongoing, fluid, conflictual and complex relationships that people describe, and that I observed among their families. Terms such as 'mixing', 'blending', 'different cultures', 'multi-cultural', 'multi-ethnic', 'mixed race', 'mixed heritage', 'diversities', 'forged', 'building bridges', 'create', 'cut off', 'struggles', 'survival' and 'accommodate' (among a host of others) were key phrases which people actually used to describe their own experiences.

During my fieldwork, I attended a picnic one afternoon in a London park with two couples: Pearl and Bert (second-generation African-Caribbean female/white British male) and Jane and Josh (white British female/second-generation African-Caribbean male). These couples are friends who consider themselves extended families though not related by blood. As we sat, ate and conversed, the topic of the difference in 'upbringing, and attitude to life' between 'black British' people (as in second-generation African-Caribbean people) and 'white British' people took centre stage, and Bert suggested that 'black British people are *creolised* Caribbean and British'. According to him, 'black British are a bridge between the two cultures, and Britain is very much influenced by the Caribbean communities. Culturally and artistically, they have got a massive influence on this society as a whole'. Bert was referring to the Caribbean music that had become a prominent feature in Britain not just among African-Caribbeans, but also among white British people, especially among the younger generation. The Notting Hill carnival was a major evidence of this phenomenon. Caribbean food has also become popular in Britain.

Indeed some social scientists have pointed to the influence of Caribbean-derived artefacts in British national life, such as phrases in popular language, music, youth's dress style and food (see Gilroy 1993; Goulbourne 2002; Henry 2005). My observations of what people in my study said and did also support this notion of the merging of cultural forms – not only of Caribbean and British, but of other nationalities. An example is the lunch a mother served me, consisting of Jamaican jerked chicken and English baked beans stuffed in a Mediterranean pita bread. I was told that this was her son's favourite meal.

A few days after the picnic in the park, I conducted an informal interview with Bert in his home. I learned that Bert's interest in African-Caribbean culture began in the 1980s when he moved to London from a small village in Suffolk, and began to socialise with African-Caribbean friends he met in college. According to him:

There is an energy and a freedom of expression about that type of music that I felt wasn't around. It wasn't about love songs, it wasn't about pop, it goes beyond fashion, it goes a lot deeper than that, than merely just what's in and what's out. It was telling me something different, something interesting. It was very much a cultural thing, an art form, so you tend to start living it. For me, it did fulfil a certain amount of creativity. There was an element of being outside of society, being in another community. A community that kind of ran on a parallel, but society wasn't aware of it, and couldn't see ...until obviously, they began to see.

The more I thought about what Bert had said, the more I came to see his insight that 'black British people are *creolised* Caribbean and British' as a potential key conceptual idea for interpreting the research material as a whole. Furthermore, Bert's insight echoed anthropologist Foner, who over 30 years ago, recognised among Jamaican migrants in Britain, a process akin to the process of creolisation that occurred in the Caribbean. According to Foner (1977: 120), Jamaican migrants in England:

are caught between two worlds: they are no longer just like Jamaicans back home, but they are also not exactly like, or fully accepted by, most English people. New cultural patterns as well as new patterns of social relations – neither wholly English nor wholly Jamaican – have emerged.

Additionally, Sheller (2003: 278) notes:

Caribbean cultures are cultures-on-the-move, which are already creole and in turn are said to have 'creolized' the metropolis. Having begun as collisions of diverse cultures that became indigenized as 'creole', they went on to spill across the Atlantic world spreading their influence into the 'global cities' that became key Caribbean cross-roads.

Sheller further states that, 'it is not only populations and popular cultures that cross international boundaries, but also more complex theoretical formations' (ibid.). Hence, we find that some key theoretical terms

for describing contemporary global culture have also travelled from the Caribbean (see e.g. Gilroy 1993; Hall 1990; Hannerz 1996; Clifford 1992). So what can we learn from the literature about the meanings and implications of 'creolisation'?

As with kinship, creolisation has experienced a variety of turns on its analytic journey, fueled by a host of debates and suggested syntheses. Moreover, as Trouillot (1998) notes with reference to the phenomenon in the Caribbean: 'Because it first occurred against all odds, between the jaws of brute and absolute power, no explanation seems to do justice to the very wonder that it happened at all' (*ibid.*: 8). Hence, 'creolisation' continues to be 'a miracle begging for analysis' (*ibid.*). As a concept, creolisation has its origins in Caribbean cultures of resistance, survival of enslavement and colonial plantations systems, as well as in movements of decolonisation (Sheller 2003: 285). The concept was first developed by Caribbean theorists (see Brathwaite 1971; Mintz & Price 1992 [1976]) in the 1970s to refer to

the agonising process of renewal and growth that marks the new order of men and women who came originally from different Old World cultures (whether European, African, Levantine or Oriental) and men in conflict. (Nettleford 1978: 2)

The concept sprung from other debates seeking to understand how 'African' or, conversely, how distinctively 'Caribbean' or 'creole' Caribbean cultures are (Burton 1997: 1). The original opponents in this continuity-creativity controversy were Frazier, an African American sociologist, and Herskovits, a Euro-American anthropologist. According to Frazier, the experience of the Middle Passage and the whole oppressive enslavement process on the plantations stripped the African-born slaves of all their family and cultural assets. Hence, in order to survive, they had to create new language, work and family customs that were often imitations of their European slave masters (Frazier 1966 [1939]). In opposition to Frazier's argument, Herskovits (1964 [1941]) argued that, in spite of the brutal conditions of slavery, some African cultures in religion, language and family forms survived unchanged, while others were reinterpreted/reconstructed in order to adapt to conditions in the New World; Mintz and Price (1992: 62-65) offer a brief summary of the Frazier-Herskovits debate. As a synthesis to the Frazier-Herskovits debate came the mediating theory arguing that from the beginning of colonialism in the Caribbean, a form of 'cultural miscegenation [race mixing] between Africa and Europe, corresponding to the sexual miscegenation of black and white' (Burton 1997:2) occurred. Thus, there evolved in the Caribbean, a distinctive 'creole' synthesised culture (Mintz & Price 1992).

One of the most significant early theorists of creolisation was the Barbadian historian Brathwaite. His thesis is put forward in a book entitled *The Development of Creole Society in Jamaica, 1770-1820*. Here Brathwaite (1971) defined creolisation as a process of cultural change 'based upon the stimulus/response of individuals within the society to their environment and – as White/Black, culturally discrete groups – to each other' (ibid.: 296). Brathwaite viewed this 'intercultural creolisation' as a 'two-way process' (ibid.: 300). Without ignoring the hegemony of the white group over the black group, Brathwaite's main objective was to illustrate the integrative effect that this 'intercultural evolution has in the emerging society' (Bolland 2002: 24). To do this, he points to the effects of 'miscegenation', which has resulted in a growing intermediate group:

The large and growing coloured population of the island, which... acted as a bridge, a kind of social cement, between the two main colours of the island's structure, thus further helping (despite the resulting class/colour divisions) to integrate the society. (Brathwaite 1971: 305)

Brathwaite's analysis of 'creole society' in Jamaica arose as a postcolonial response to Caribbean cultural anthropology in the mid-twentieth century, which was largely influenced by M. G. Smith's 'plural society' thesis (Sheller 2003: 279). Smith (1965) argued that within each Caribbean society are separate 'racial', 'cultural' and social segments that maintain separate and distinct practices and 'institutions' – 'a form or system of activities characteristic of a given population' (Smith 1965: 163) – and these segments and corporate groups are held together and controlled by the dominant central or colonial government. Smith focused on institutions such as kinship, religion, education, recreation, economy, property and government (ibid.: Chapter 7). From his study of Jamaica, he argued that there are no common values between the different cultural or social sections characterised as 'white', 'brown' and 'black' (ibid.: 163), and that 'the coexistence of these divergent value-systems within a single society involves continuous ideological conflict' (ibid.: 174).

Brathwaite's creole society, like Smith's plural-society model, focuses on the significance of culture in Caribbean societies. However, counter to the plural-society model that emphasises the persistence of social segmentation and conflict between each racial and ethnic groups, the creole-society model stresses an evolving cultural integration and homogenisation of people from diverse racial and ethnic origins into one national ethnicity, based on the creation of a new creole culture (Bolland 2002: 23, 29). In short, the central argument of Brathwaite's creole-



society thesis is that the Africans and the Europeans who settled in the Americas/Caribbean ‘contributed to the development of a distinctive society and culture that was neither European nor African, but “Creole”’ (ibid.: 23). Thus, the creole-society model, which advocates a notion of social and cultural change, is the seedbed from which the concept of ‘creolisation’ germinated ‘and a concept that is now widely used to refer to processes of the creative reconstructions and cultural changes in the Caribbean and elsewhere’ (ibid.).

Other Caribbean intellectuals such as Patterson (1975), Nettleford (1970) and Alleyne (1985, 1988) have also contributed to the concept of creolisation, offering variants of the creole-society thesis by exploring issues of post-independence Caribbean societies (for a more detailed view of these variants on the concept of creolisation see Bolland (2002: 26-30)). In brief, what supporters of the creole-society model offer is an approach similar to Brathwaite’s (1971) model of national integration/homogenisation with an emphasis on social and cultural change, and only implicit reference to structural contradictions and social conflicts between the different segments in the Caribbean societies.

More recently, Bolland (2002) made a cogent attempt to synthesise the creole-society thesis (his synthesis has been endorsed by others such as Burton 1997; Sheller 2003). Bolland has challenged the creole-society thesis for its theoretical ambiguities, and has developed an alternative ‘dialectical’ view of creolisation. Bolland (2002: 29) contends that ‘conceptually, “creolisation” and “Creole-society” remain ill-defined and ambiguous’. While it draws upon anthropological theories of culture change, it moves back and forth between a ‘dualistic’ and ‘dialectical’ analysis of individual and society, thus lacking a consistent and explicit theoretical basis (ibid.: 18). On the one hand, the creole-society model portrays the social structure (society) as a ‘Black/White dichotomy’ (Brathwaite 1971: xiv cited in Bolland 2002: 30), and the creolisation process as a ‘cultural action...based upon the stimulus/response of individuals within the society to their environment and – as White/Black, culturally discrete groups – to each other’ (Bolland 2002: 296). According to Bolland (ibid.: 30), this dualistic view portrays creolisation as a:

‘Blending’ process, a mixing of cultures that occurs without reference to structural contradictions and social conflicts... [Thus], it obfuscates the tension and conflict that existed, and still exists, between the Africans and Europeans who were bearers of these traditions.

On the other hand, Bolland notes that the creole-society model does draw attention to conflicting relationships and the tensions that arise in

the processes of social and cultural change, but only implicitly. For example, Alleyne, a creole-society theorist, analyses the development of Caribbean creole languages as ‘contradictory, conflict-prone and insecure, ambivalent in outlook and attitudes, ambiguous in their formation and in their functioning...’ (Alleyne 1985: 158 cited in Bolland 2002: 30). Bolland contends that such ambiguities with a dualistic view on the one hand and an implicit dialectic outlook on the other hand does not provide a sound theoretical basis for the concept of creolisation. Hence he proposes a more explicit dialectical analysis of creolisation that takes into account the ‘interrelated and mutually constitutive nature of “individual”, “society”, and “culture”, and of human agency and social structure’ (Bolland 2002: 30).

I found Bolland’s dialectical theory of creolisation most useful for analysing the experiences of the families in my London research. As he points out, ‘dialectic theory draws attention, in particular, to conflicts in social systems as the chief sources of social change’ (ibid.: 31). Bolland reminds us of the power relationships that define and differentiate many social relationships – relationships of domination/subordination – and that as forms of oppression vary from one society to the next, so do the locations and kinds social change. He points to Marx’ nineteenth-century capitalist society and relationships of social class, in understanding the dynamics of that society. However, Bolland rightly points out that class is not the only relationship of domination/subordination: ‘On the contrary, various forms of oppression are based on status inequalities, defined in terms of race, ethnicity, gender, age and legal status, or a combination of these as well as class’ (ibid.). This book on the London families illustrates various examples of power relationships that operate not only between individuals and the ‘society’, but also among individuals within families.

Moreover, by endorsing a dialectical view of creolisation for analysis of the London families, I am able to take the analysis beyond the point of simply ‘mixing’ and ‘blending’ of people and traditions, to show how these individuals/families in London who, from the very start of their relationships are made to feel subordinate, have nevertheless managed in many ways to shape their own culture and make their own history. As the following chapters demonstrate, despite harsh experiences, they have been very active in adapting and in seeking strategies to subvert the goals and structures in their society and within their families.

In sum, it is Bolland’s general conclusion about the process of creolisation that I find most relevant for analysis of my own London research.

Creolisation is not a homogenizing process, but rather a process of contention between people who are members of social

formations and carriers of cultures, a process in which their own ethnicity is continually re-examined and redefined in terms of the relevant oppositions between different social formations at various historical moments. (ibid.: 38)

More specifically, creolisation is also linked to the forms of family and kinship relatedness in Caribbean societies, as Mintz and Price (1992), Besson (1995, 2002a, 2002b) and R. T. Smith (1988) have cogently shown. It is argued that the West Indian creole kinship system began during slavery and the plantations system, and was the result of the denial of the right to establish socially recognised families and lineage among the slaves by their masters (Henriques 1968; M. G. Smith 1957; T. R. Smith 1957). Despite the experience of fragmentation of their traditional bonds, the lack of knowledge of genealogical affiliation and the conditions laid down by their masters, the slaves were still able to symbolically reconstruct family and kinship forms, 'either by various forms of ritual kinship or by spiritual (religious) ancestry' (Fleischmann 2003: xx). Moreover, as Mintz and Price (1992 [1976]) illustrated, the social bonds that developed between shipmates during the Middle Passage, continued on plantations in many parts of Afro-America. These bonds extended beyond the original shipmates themselves to include other biological and non-biological kin.

According to Mintz and Price (1992) these 'shipmate' bonds that began on the Middle Passage among the slaves, continued on the plantations, and were synonymous in the slaves' view with 'brother' or 'sister'. These fictive kinship bonds extended 'beyond the original shipmates themselves and interpenetrate with biological kin ties'. Thus, on the plantations, 'shipmates were said to "look upon each other's children mutually as their own", and it was customary for children to call their parents' shipmates "uncle" and "aunt"' (Mintz & Price 1992 [1976]: 43). Among the families in the post-emancipation free villages and the post-treaty Maroon community in Jamaica, Besson (1995) also found that the kinship terminology that has evolved among the complex conjugal, cognatic descent and bilateral kinship system, evolved through the process of creolisation on the basis of the shipmate bond (Besson 1995: 195-198).

Such fictive kinship therefore, was the very basis of the new African-American slave cultures, and the consolidation of kinship and marriage systems became a central theme in the culture-building of the slaves. (ibid.: 187)

Additionally, it has been argued that the complex creole kinship system of 'dual marriage' (consisting of both legal and non-legal marriage)

involving multiple residences is rooted in colonial history. Such family patterns exist among different class and racial groups in the Caribbean today, and generate extensive bilateral cognatic descent kinship ties and 'matrifocality' (see Besson 2002a: 18-19; 1995; Smith 1996, 1988; Green 2006). Moreover, these family and kinship patterns were not only practised among the slaves, but also among the planter class through interracial relationships with African slave women, and transnationally between the colonies and Europe (see Green 2006). Many planters who resided in the colony had white wives with whom they were either co-resident or headquartered abroad, while simultaneously in relations of concubinage with black women, enslaved or free (Green 2006: 16; Bush 1990). According to R. T. Smith (1987: 167), this 'dual marriage' system, which began from the beginning of the plantation system, was 'a system in which the elements were mutually and reciprocally defining and which articulated with the racial hierarchy'.

In the 'dual marriage' system, white male planters became the mediating biological and social link between two or more sets of families. They facilitated the reproduction of two different race/class lines (Green 2006: 16): a legitimate line with the white master as common genitor and reproducer of white 'paterfamilial propriety and racial superiority' and an illegitimate Afro-Creole matrifocal line of a mixed intermediate class (*ibid.*: 18).

Just as marriage came to be an exclusive property of the very wealthy and a mechanism for the transnational reproduction of the Euro-Creole upper class, concubinage came to be the means by which a 'bastard' intermediate class was bequeathed to the societies of the West Indies by the planters and their surrogates as the social superiors of the slaves and, later, of the Black peasantry and working class. (*ibid.*)

Upon emancipation from slavery, pressure was directed at the African ex-slaves by the British and American missionaries and the British Parliament to conform to the European form of marriage and family (West India Royal Commission), but these efforts failed among the majority of the ex-slave families due partly to economic constraints (Henriques 1968). Contemporary Caribbean family forms continue to exhibit features of the creole family system that existed during slavery and the early post-emancipation period. Besson, for example, illustrates the continuation of the creolised slave kinship system in the post-emancipation free villages and the post-treaty maroon community of Accompong in Jamaica. She shows how cognatic descent, bilateral kinship, and a 'dynamic "complex" or open system of marriage and affinity, linked both to serial polygamy', and 'a high incidence of half-

siblingship', all interrelate 'to maximize dimensions of consanguinity and affinity [originally] elaborated through the process of creolisation on the basis of the shipmate bond' (Besson 1995: 194-195, 198, 2002a: 281). It is striking how often I found among the London families similar patterns of multiple conjugal forms, serial monogamy, a high incidence of half-siblingship and 'wide-spread bilateral kinship ties with no boundaries', which Besson described (2002a: 281).

R. T. Smith (1988) shows that, in Guyana and Jamaica, 'the family structure of different classes and racial groups can be understood as variations on a common structural theme' (Smith 1988: 7). What Smith identifies as the 'matrifocal family' structure found in the Caribbean is not 'simply the consequence of certain functional problems within an ideally conceived nuclear family' (ibid.: 8). Instead, it is part of a complex of meaning and action that involves all classes and status groups, and which 'constitutes the West Indian creole kinship system' (Smith 1988: 8). Indeed, among these London families, many women become household heads across class and racial groups. This does not necessarily result from 'functional problems', but is often due to personal choice.

Migration across islands and oceans continues to be a central feature of Caribbean creole cultures. Although migration disrupts family bonds, Caribbean families have maintained kinship relations transnationally through a network of relations – both blood and non-blood relatives – making all sorts of links that provide emotional, financial and other forms of aid and support (see Bauer & Thompson 2006; Besson 2002b; Byron & Condon 2008: Chapter 6; Chamberlain 2003, 2006; Goulbourne & Chamberlain 2001; Horst & Miller 2006; Levitt 2001; Thomas-Hope 1998; Reynolds & Zontini 2006; Goulbourne et al. 2009). As Fleschmann (2003) points out, the capacity of the Caribbean family to construct and reconstruct ethnic and kinship ties – the legacy of slavery and labour migration – viewed from the angle of globalisation becomes a 'modern asset' (ibid.: xxxii). Among the families in my London research, members also actively maintain links to cognatic descent groups in the Caribbean and in North America through transnational kinship.

In my view, the process of creolisation – in terms of the creation and recreation of families – is also a 'process of kinship' (see Carsten 1997). Thus, I strongly believe that creolisation is an appropriate theoretical concept for exploring the development of mixed African-Caribbean and white British families in London for a number of reasons. Although the concept is more generally used to describe societies in the Americas and the Caribbean (see e.g. Besson 2002a; Bolland 2002; Brathwaite 1971; Mintz 1996; Trouillot 1998) and concepts such as transcultural, cultural hybridity, diasporic identities and globalisation (among others)

have become the popular rhetoric among social scientists, as Trouillot points out, they are only masks for the creolisation process that still goes on globally. Hence, 'the creolisation process in the Afro-Americas appears, in retrospect, as an early state of grace only now accessible to the rest of humanity' (Trouillot 1998: 15). This is evident in issues raised by social scientists such as Gilroy in *The Black Atlantic* (1993) and Hall in *Cultural Identity and Diaspora* (1990, 1999).

Secondly, and particularly relevant for the families in the London study, unlike hybridity, which points to the process of biological reproduction and genetic recombination (Maurer 1997: 11-13; Röhrig Assunção 2005a: 34), creolisation points to history, 'the different, contradictory processes of cultural interaction' (Röhrig Assunção 2005b: 161), the change in families that occur through a process of mixed socialisation and the circumstances (often harsh such as violence and racism) faced by individuals engaged in the process. Moreover, it is a process that is never fixed, but is always being created and re-created, as is the 'process of kinship', which is 'a process of becoming' (Carsten 1997: 12).

Thirdly, and also very important, in my view, the concept of creolisation most adequately encompasses individuals' spoken narratives regarding their own experiences of 'mixing', 'blending' and 'integrating', 'accommodating' as well as the 'joys', the 'struggles' and the ambiguities involved in 'crossing boundaries' and 'adapting' to 'create' 'mixed-heritage' families. Additionally, with regard to family strategies for surviving, unlike acculturation, which implies passive adaptation, their *active* adaptive strategies are more akin to creolisation.

In sum – without any single clear-cut grand theories – what the themes and threads running through this book illustrate is the development of mixed white British and African-Caribbean families in London over historical periods and contexts. Along with the other conceptual tools outlined, I believe that the concept of creolisation is also useful for understanding these mixed-heritage London families. For example, with regard to their forms of relatedness, for many of them, the strategies they have employed – such as forms of marriage, patterns of residence, forms of parenting, extension of family and kinship ties to non-biological kin, etc. – are forms of relatedness that are still not generally considered the 'norm' in British society. Therefore, they have had to find ways to modify and transform certain codes of conduct that already exist in their families of origin, and in the social structure as the 'normal' ways of being.

I do not by any means intend to essentialise these families by implying that their experiences are only unique to them. Contact between any different groups of people inevitably requires negotiations and adaptations against the background of socially sanctioned modes of

conduct. In her essay 'Future kinship and the study of culture', Strathern alluded to the creolisation of English kinship when she stated that:

The English could draw on the family as a metaphor for thinking about continuity and change alike. For families might either appear as autonomous entities with their own traditions, as constellations of unique properties (and property) transmitted between generations, based on a line of natural ancestry; or they might appear as constellations of individuals who worked together or who moved away from one another, and who in any case diversified their interests, renegotiated their obligations and chose with whom they associated. (Strathern 1992b: 53-54)

Regarding individuals and the study of culture, Strathern points to the difficulty in sustaining the 'conventional mid-century understanding of culture as a traditional body of "shared" values and attitudes that individuals constantly reinterpreted or realized or challenged in their own lives' (ibid.: 54). She questions whether anthropologists shouldn't instead be drawing 'on the idea of the cosmopolitanised and always plural culture, or even perhaps the *creolised* language' because 'despite the apparently exotic origins of these constructs', they also resonate with 'English ideas about procreation' (ibid.). Strathern views 'the city' as 'a source of cultural change' where cultures are increasingly becoming 'creolised' and 'traditions becoming fainter' (ibid.: 55).

Strathern's reference to the changes in British kinship has partly to do with the consequence of 'artificial procreation'. However, whether one is referring to artificial procreation or 'miscegenation', with regard to kinship among mixed African-Caribbeans and white British families, it is about creating something new, even though from already existing elements. Furthermore, the concept of creolisation incorporates the different and often contradictory processes of cultural interaction and cultural creation/recreation that are employed in analysis by many creolisation and cultural theorists. In trying to understand the family and kinship patterns that have developed in the context of the 'Black Atlantic' (Gilroy 1993), creolisation could prove a useful conceptual tool for analysing the changes in family forms, practices and values that have evolved over time. Mintz, himself an original advocate of the concept, recognises that, although creolisation as a concept was born in the Caribbean, and what the word represents was first studied in the New World, these processes are also occurring in Europe and the rest of the western world (Mintz cited in Besson 2002a: xvi). Creolisation is also linked to specific forms of family and kinship relatedness in Caribbean societies, and I believe that the concept may equally fruitfully be used

to describe the process of kinship among mixed African-Caribbeans and white British families in London. I now move on to illustrate the usefulness of these several theories in the chapters that follow.



### 3 Coming together: A case study of the Smith family

In Chapter 2 I showed how individuals' understanding of their own experiences expressed through their life story narratives, has informed the theoretical focus of my research – the process of kinship and forms of relatedness as a process of creolisation. In this chapter, I use the case study of a single family, the Smiths, to explore how, as more generally with the wider process of creolisation, this particular family *does* kinship and relatedness. As I learned, the Smiths do this through a non-static, non-homogenising process of re-creating, re-inventing, incorporation, adaptations and negotiations of social and cultural processes that involve biological as well as non-biological relatives.

The chapter takes a historical and anthropological look at the Smith family from the 1950s to the present and across four generations. Although other families in the research often had some similar experiences as the Smiths, there is uniqueness in every family. Therefore, the Smith's family case should not be generalised to all the families in the research. On the other hand, by focusing on a single case, I am able to draw out individual experiences and diversities, and illustrate different aspects that unite members of family into kinship. The narratives from the Smith family are multiple, so that whenever I am using extended quotations I indicate who the speaker is. Otherwise, I simply indicate with quotations marks, the specific words and phrases that people used.

#### **Dawn and Dusty Smith: The early years**

Dawn Smith is the eldest child and only daughter of an Irish family of three children. Dawn's father died while she was still a child. Consequently, she and her eldest brother left school from an early age to work and help support the family. As a young woman in the late 1940s, Dawn left Ireland with two friends and moved to London to find work and, as she said, 'do something with my life'. All three young women found work in the same brewery, and lived in shared and cramped accommodation. From her weekly £4 earnings, Dawn paid for her lodging and sent money home to her mother for financial help, which left her with very little for leisure. At the brewery, Dawn met another

woman, Clara, also from Ireland, and they became very close friends. Dissatisfied with her living conditions, Dawn went to live with Clara, who had invited her to share the room she was renting with another woman in a house. Having no other relatives in London, Dawn and Clara became lifelong 'sisters'.

Dusty Smith left Jamaica for London in the 1940s. He, too, lived in a house with 'a lot of other people'. He worked as a driver in the Royal Air Force and later as a manual labourer in various factory jobs in London alongside people from various ethnic groups. In 1950, Dawn and Dusty met one Friday night at a dance and 'danced to a few tunes'. They hadn't exchanged personal details that night, but on the Monday morning when Dawn arrived at work, she saw Dusty at the brewery looking for work. Dawn's first instinct was that Dusty had come to 'harass' her. Instead, he had shown up for a job that he had seen in an advertisement. He applied, got the job, and their rationale for this extraordinary coincidence was that 'fate had decided' their union. They developed a very close friendship, which led to an intimate relationship.

Before meeting Dusty, Dawn's friends were all people from her own ethnic background. Dusty, on the other hand, had a more ethnically diverse group of friends, many of whom were 'mixed-race' couples. After the couple came together, all of Dawn's friends except Clara discontinued their friendship with her, leaving her with a network of friends who were primarily Dusty's friends.

Shortly after their relationship became intimate, Dawn became pregnant, and the couple decided to live together. They knew it would be difficult at the time to find housing as a couple of Irish and African-Caribbean origins, because this was during the period when racism was severe in Britain. By this date, many of the prejudices and anxieties that the English held of the Irish – with regards to differences in religion, custom and competition in an overcrowded labour market – had lessened. Hence, when large-scale Caribbean migration began, the Irish were no longer the main targets for discrimination. Nevertheless, the stereotype of 'the Irishman as drunken, dishonest and rowdy [was] still a reality to some English landladies and magistrates' (Jackson 1964: 205). Thus, advertisements for housing appeared in local London papers and on notice boards stating, 'No Blacks, no Irish, no dogs' (Glass 1961; Jackson 1964; Patterson 1965). Furthermore, during the early 1950s, London's landlords and landladies who kept a 'respectable' house did not usually accept unmarried couples and couples with babies 'because of noise and other possible nuisance value' (Patterson 1965: 187). However, Dawn and Dusty responded to advertisements in the newspapers, with Dawn making the phone calls: 'I just read in the newspaper you have a room to let'. The landlord or landlady would respond: 'Yes, yes, yes, dear, come along'. The couple turned up, only to

hear: 'Oh, the room is gone!' or 'Oh, I went out and my husband let the room!' After a series of such responses, they resorted to announcing while inquiring for accommodation that, 'One of us is black!' They eventually succeeded in securing a place to live – one room on the ground floor of a house, with shared kitchen and bathroom. However, they could not disclose to the landlord that they were neither married nor that they were about to have a baby.

## Getting married

When Dawn became pregnant, Dusty asked her to marry him, but because of Dawn's age, the laws required consent from her mother. Dusty asked Dawn to write to her mother and ask for permission to marry and also to tell her that he was 'black'. Dawn, who had grown up a Catholic, wrote to her very religious mother Sue, who replied stating: 'He could be a white man, green man, black man, coloured man, he could be any kind of man as long as he's Catholic!' Dusty, who had grown up as a boy attending the Church of England, had, he said, 'finished with those things' as a young adult. He had taken on very strong political views, and no longer believed in 'going to church every Sunday or going to Heaven when you die'. However, since the only condition under which he would be allowed to marry Dawn was to convert to Catholicism, he complied. Thus, before they married, he became a converted Catholic. Very shortly after he converted, they became married in the local Catholic Church. Dusty's younger brother Peter, whom he had helped migrate to London, and Dawn's sister Clara were their witnesses and the only people who attended their wedding ceremony.

Getting married was an event in itself for the couple. Because their landlord was unaware that they were living as a common-law couple, they planned the event covertly. Additionally, in order to avoid becoming public targets of racism, Dusty and Peter walked on ahead to the church, and Dawn and Clara followed some distance behind them. After the wedding ceremony, Dusty and Peter went to the local pub 'for a drink', while Dawn and Clara went for a 'cup of tea'. They had invited a few friends to their room that evening to celebrate their wedding, but, because they couldn't disclose the real reason for the party to their landlord, they asked him for permission to have a 'little birthday celebration'. Permission was granted under the condition that they keep the noise and the music down. They dismantled the bed in their one-room basement flat, and stored it in the shed in the back garden to make space for socialising. Dawn recalls how 'In them days, you didn't turn off the lights by a switch like you can now, they automatically went off at ten o'clock'. At ten o'clock sharp the lights went out and, although

they had secured some candles to provide light, the landlord was standing at their door commanding an end to the party. Left alone in the dark, they found it impossible to retrieve their bed from the shed, so they spent their wedding night sleeping on the floor.

### **No space for the baby**

Shortly before it became obvious, the couple informed their landlord that Dawn was pregnant, and he asked them to leave. However, they were unable to secure housing before the birth of the baby and, when the couple arrived home from the hospital with baby Polly, their landlord insisted they leave immediately. Devastated, Dawn wrote home to her mother Sue back in Ireland and told her about their situation. Sue agreed to take Polly to Ireland and care for her until they were able to have their baby back. As Clara – Dawn's fictive sister – was returning to Ireland for a visit, it was she who brought three-week-old Polly to live with her grandmother.

Back in Ireland, Dawn's two younger brothers John and Toby were still living at home with their mother in a small two-bedroom house, so Polly slept with her grandmother at nights. Polly's first formative years were spent with her grandmother, who became her 'mother', and her uncles became her 'big brothers'. The families kept in touch mainly through letters. Dusty and Dawn sent regular parcels of money, clothing and toys for Polly, and Sue took photographs of Polly in her new dresses and send them to her parents.

### **Buying a home**

Back in London, Dawn and Dusty had moved out of their original rented room to another room in a house they rented from a friend of Dusty's. Eight months after Polly's birth, Dawn became pregnant with Mark. Desperate for more living space by now, they began to save money to buy a home of their own before the new baby arrived. They bought a very large fifteen-room house that had been divided into flats, in 'very bad condition', in north London for £1,300. The house had three floors and a basement, and 'every room needed repair'. It also came with existing English tenants. After moving into their new home, Dusty, who had no experience in home repairs, read library books on home renovations and decorating, and after his work on the railways during the days, he worked tirelessly on the house in the evenings, 'fixing it room by room'. They took in some of their friends who, like themselves, had experienced difficulties in finding accommodation. In

exchange for lodging, these friends helped with the house repairs. Once the repairs were completed, their friends remained in the house, some paying 'what they feel like', others 'paying nothing'. According to Dusty: 'It was alright, because they were my brothers'.

### **Inside the big house**

As the house got fixed 'room by room', Dawn and Dusty took in more lodgers like themselves who were having difficulties finding accommodation. Dusty recalled that at various times there were individuals and couples:

From the Caribbean, African people, a German woman living with a Trinidadian man, an Irish girl with a Jamaican chap, another Jamaican guy with an Englishwoman who had twins, one very dark, and the other was light and blonde. There were also four Chinese-Jamaican brothers living in the big house. One was married to a French girl, one was married to an Indian-Jamaican woman, and another one was married to an English white girl.

Thus, in the process of solving their own housing difficulties, they also created a new space for ethnically mixed sociability.

About two years after moving into the house, when the renovations were completed, Dawn and Dusty decided that it was time for Polly to come back and live with them. Their son, Mark, had been living with them all along. By now Polly was four years old, and had bonded with her grandmother, who had become her 'Mum'. When Sue told her grandchild 'Your mum's coming to take you back to England', Polly was confused and upset – so upset that when Dawn arrived to bring her back, she refused to go without Sue. Hence, Sue accompanied Polly and Dawn back to London and she remained in the big house for a few months, in order to help Polly adapt to her new environment and her family.

Adaptation was not an easy process for Polly because, having been separated from Dusty and Dawn at three weeks old and knowing only her grandmother as her mother and her uncles as her brothers, meeting her own parents and her brother for the first time was emotionally difficult. One of the most difficult times she recalls was the day her grandmother told her that she was going to the butchers, but never came back. 'I felt that I had been tricked, that she'd gone. And it was an enormous house, so I just felt lost. I can't describe how big it seemed. Loads of stairs up to the attic, and lots of different people living in the house'. After Sue left, Polly's adaptation was facilitated by having her

fictive 'Auntie' Clara's children – 'cousins' Leah and Sam – in the house much of the time. As Polly recalls:

My cousins were the only other children in the house apart from my brother and me. They didn't live there, but they were there a lot, and they would come on Fridays and spend the whole weekend, or I would go over to Kentish Town and stay with them a lot.

Hence, by this point, the house had become not just a setting for mixed sociability, but also for a creolised cross-ethnic form of fictive kinship. Polly continued to see her grandmother every year because Dawn sent the children for six weeks each summer to spend their holidays with their grandmother. This pattern continued until Sue migrated to London – at Dawn and Dusty's persuasion.

### **Family inside the big house**

Inside the house there was a complex network of relations. There were lodgers who were mostly friends of Dawn and Dusty's, friends who had become 'brothers' and 'sisters' and children who had become 'cousins'. Also in the house were Dawn's two younger brothers John and Toby, whom she had later helped to migrate from Ireland, and Dusty's younger brother Peter, whom he had also previously helped to migrate from Jamaica. Peter's wife Jean also lived in the house until they bought their own house and moved out. Some years after Dawn's brothers migrated to London, Dusty and Dawn invited Dawn's mother to join them. Sue migrated, but bent on maintaining her independence, she decided to get a flat of her own. The Smiths found her a flat not far from their home. They also found her a cleaning job a few days per week, and on weekends she lived with them in the big house, where she spent most of her time socialising with Dusty and his friends, watching sports and gambling. Thus, although the Catholic Church was an important part of social life for Sue in Ireland, in London, she – like Dawn and Dusty who converted to Catholicism so he could marry Dawn – no longer attended the church. Thus, Jackson's argument, that 'The close link between Church and society in Ireland has made the Church a centre for immigrant life in England' (Jackson 1964: 306) was not true for the Smith family.

Within the complex network of relationships inside the house, there also existed different forms of relationships between the couple and the other individuals. For example, the nucleus of the family had the closest ties both with their blood relatives – Dawn's and Dusty's brothers and

Dawn's mother – and Jean who was an affine (Dusty's sister-in-law), as well as with Clara and her two children who were non-blood. These relatives formed the immediate extended family ties, and these were the people who were constantly exchanging material and emotional support. Outside of this immediate set of relations was another set of friends who were also considered as 'brothers', and were the people who shared some practical support, but mostly friendship and leisure. Polly's childhood memory of the house 'was like a kind of community once you get inside the front door. A big community. It was very friendly, and it was nice'.

It was great for me because, as a little girl, I could go to the top of the house with the two attic rooms at the top. My Uncle Peter, my dad's brother, lived in one of them with his Jewish wife Jean, Auntie Jean. She wasn't practicing [Judaism], and I think her family ostracised her. They lived in one room. There was another Jewish girl who married a Jamaican living in the house, and the same thing, I remember her telling me that her parents wouldn't have anything to do with her, 'cause I used to go to everybody's room and hear all their stories. And there was Marjorie and the Trinidadian man, Simon, living in the front room.

So I'd knock on the door, and everybody would let me in, and I'd spend half an hour in one room talking, and playing with all their little things, you know, the ornaments. And Marjorie would tell me about Germany, and Simon would tell me about Trinidad, and they'd have their music on. And then I'd get bored and I'd go to another room, sit in there for a little while and... everybody was very welcoming. There was always lots to do, you know, and lots of people you could go and sort of talk to in the house. And I suppose everybody made a fuss, because me and my brother were the only children in the house at the time – except for the weekends when Auntie Clara's children, my cousins Leah and Sam, would come and stay with us.

Then on Fridays and Saturdays all the 'boys', as they were called, all the grown men in the house would gamble. All weekend in our living room... In those days, children could go to the off license and buy booze, no problem with cigarettes. So they would give me the money so I'd go and buy a bottle of whisky, cigarettes and whatever else they needed. And they'd finish their gambling and there was a big clean-up operation in the living room, which I had to do. Any money that was found, like a two shilling, or two and six, I could keep it, sometimes quite a bit of money.

As with most communities, there was both cohesion and conflict between members inside the house. Sometimes fights broke out between couples and other individuals over some disagreement. One of the Chinese-Jamaican brothers, for example, periodically lost his temper and ran around with a knife. This incited fear and fury, and sometimes resulted in fights 'and people tumbling down the stairs'. Mark recalled how frightened he and his sister Polly would become: 'My heart used to race. I used to be so frightened that somebody would get killed, because it always sounded so violent'. Furthermore, there was added tension from the disapproving neighbours who had not been very welcoming to the Smith family when they moved in.

### **The neighbourhood and experiences of racism**

When Dawn and Dusty moved into their neighbourhood in the early 1950s, it was 'predominantly white'. They were the only 'black family' on their street until the mid-1960s. According to Dawn:

Nobody in the neighbourhood would talk us. They put swastika on me door, shit on me door. Yeah, when I wake up in the morning, there would be all that on me door... 'Get out, you black bastards' would be written in black. What could you do? You just wash it off! What else could you do? Just go on as if you didn't care. That went on for a good while. When I took the children out, nobody would talk to me.

Dawn's way of coping with such racism was to ignore it as much as possible, to feel proud of their achievement in securing a home and proud of her family: 'I just thought, "This was my house, this was mine!" And I was proud of myself for having a house. Didn't think of the colour of my husband. He was my husband, and we were together, and that was it. What they want to think outside is their bloody business'. Outside their difficulties with housing, Dusty who was constantly out working did not encounter such blatant racism as Dawn. His worst experience in the neighbourhood was down at the local pub, where the bartender refused to serve him drinks.

It was the children, however, who experienced the most frequent racism. Not only were the Smiths the only family of their kind on their street and in their neighbourhood, but their children were, according to Polly, the only 'other' children in their school. Polly and Mark experienced all sorts of racial abuses from name-calling – 'nigga boy', 'nigga girl', 'half-caste bitch' – to being physically attacked at school, and having stones thrown at them as they walked home. At her primary school,



Polly made friends with some of the other girls. Although she was never invited to their homes, she sometimes brought friends home with her. However, she stopped inviting them home when one girl scorned the rice and peas and chicken she was having for dinner, and called it 'kitty cat' (as in cat food) – apparently, there was a myth in the 1950s and 1960s among the local white people that 'black people' ate cat food.

Additionally, because the mixed couples in the house found few clubs and pubs that welcomed them, they made most of their entertainment inside the house. This gave Dusty and Dawn the idea of setting up a nightclub in the basement of the house, where they held regular parties and invited other couples like themselves. This arrangement created conflict between the community inside the house, and the community and neighbourhood outside the house.

Disapproving neighbours called the police whenever the Smiths had a large party that involved friends parking their cars on the road. Consequently, the house was regularly raided by the police, who were looking for stolen goods and drugs. Polly recalls how the police often came knocking at the door and 'stormed' in with their dogs:

My brother and I used to be asleep in the bedroom and the police dogs used to come into the bedroom and sniff at our faces, and we used to hide under the covers. And my mum would be screaming 'Get out of there, my children are in there, there's nothing in there!' It was quite terrifying, dramatic and everything.

### **Coping with racism**

Although there was never any evidence of any illegal activities in the house, after each police raid Polly remembers finding it particularly 'embarrassing to get up and go out and face the world, knowing that all the neighbours behind their twitching net curtains are talking about us'. For Mark, there was always 'an element of trying to hold my head up high, looking as though nothing had happened, and knowing that everybody disapproved of what they perceived was going on in the house – a kind of reconciling yourself with the rest of the world really'.

Dawn and Dusty found various strategies to deal with the discrimination their family experienced outside the house. Dawn's tactic was to ignore the verbal abuse from the neighbours, and clean up whatever 'mess' was on their door and front lawn. But for Dusty, despite the discrimination his family experienced, his tactic, in his words, was to 'try to fit in like a jigsaw, get in the puzzle'. He wanted to integrate into the neighbourhood by conforming to the standards he observed: 'I behaved

myself as how I see people behave there'. He never played loud music, and he kept a clean yard. Furthermore, he continued to be courteous by saying 'Good day' to everyone he passed on the street, whether or not they responded.

Where the children were concerned, Dawn and Dusty advised them to 'Fight back!' This strategy sometimes resulted in unpleasant experiences. However, in one instance, it led to an unexpected social mixing. After Mark's consistent experience of verbal racist abuse by a group of his white schoolmates, one day he fought back and broke the tooth of one of the boys. That evening, their doorbell rang, and Dawn opened the door to find the boy and his mother standing on the doorstep. 'Look what your son did!' said the mother. 'What happened?' asked Dawn. 'He punched his tooth out!' said the woman. 'Why?' asked Dawn. 'There must be a reason why he did it, mustn't there?' Dawn called Mark who explained that the boy had been calling him names. Dawn asked the mother to imagine what names her son was calling Mark, and how she would react 'if the shoe was on the other foot'. The boy's mother 'gave in' and invited Mark for tea that same evening. With Dawn's permission, Mark followed, and that was the 'breakthrough' to a lasting friendship between the boys. Eventually, Mark went for tea nearly every evening and the family invited him to join them on week-ends away.

Mark also developed his own strategies to deal with racism at school. He tried to integrate by joining the football team that helped him to become 'more popular' and 'bond' with the other boys. For Polly, coping with the discrimination she experienced in school was a more difficult and 'lonely' task. She remembers her school dances when her schoolmates 'were predominantly white', and where none of the 'white boys' ever asked her to dance. There was also the memory of her geography lesson when the teacher showed pictures of poor people in Ghana, and the other children in the classroom 'were sniggering and laughing, and I remember feeling this deep sense of "Please let that stop! O God, don't show that! Take that away!"' Polly felt 'hurt and embarrassed', but couldn't share her feelings with anyone in her school. Fortunately for her, she had very influential teachers who not only encouraged her in her schoolwork, but also supported her against discrimination in the school. She was very bright, and that gained her friendship with some of the other girls who sought her help with their schoolwork.

### **Ten years on: Family and social life in the 1960s**

We now move on to the 1960s, when the Smiths had been living in the big house for a decade. By now, most of the people originally living in

the house had established themselves economically and moved into their own homes. Dawn's brothers John and Toby had married and moved, and Dusty's brother had also moved out with his wife. The only family members left in the house were the couple and their children. Dawn's mother Sue, her sister Clara and Clara's two children continued to be regular visitors in the house.

Dawn and Dusty decided that the house was too large for their family alone, and decided to run it as a guesthouse for temporary students learning English. Still determined to maintain the ethnically diverse and multicultural quality that was always a feature of the house, Dawn went to the National Union of Students and placed a request for students from different nationalities. She requested two Spanish, two French, two South Americans, two Africans and two Japanese students and so on, because she 'didn't want my house full of students from the same country. Didn't care where they come from in the world'. She accommodated a maximum of fifteen students at any given time, with a maximum of two students per room. The students were responsible for making their own suppers, while Dawn's main role as a proprietor was to clean their rooms and make their breakfast. She was soon in desperate need of help to run her guesthouse, and it was during this period that her sister Clara gave up her job to work full-time as a domestic helper in the big house.

Dawn's enthusiasm for mixed social interactions seemed limitless. Very early on, she observed how inefficient suppertime had become for the students, as each of them took their turn to cook their individual meals, a process that lasted late into the night. She called a meeting with all of her student boarders to recommend a system that not only made suppertime a more efficient event, but also into a 'multicultural affair'. Dawn suggested:

Each morning at breakfast, what about all of you pooling your money, put it in the middle of the table. Everybody give the same amount. Two Spanish girls: take the money, you go some time today to buy enough Spanish food to feed everybody. Two French girls: you wash up when you finished and tidy the place. Tomorrow, the two Africans: you cook for everybody. And the South Americans: you tidy up. Japanese: you cook the next night, and so forth.

This system created an endless array of multicultural cuisine in the house, and gave the students the opportunity to enjoy food that they hadn't tasted before in their own countries. Sometimes they incorporated dishes from their different nationalities, and invited members of the Smith family to join them for supper. Additionally, Dawn had

learned how to cook Jamaican food, and often combined her cultural British cuisine with Dusty's Jamaican cuisine. There were regular 'feasts' in the garden, combining cuisines from all the different nationalities of people in the house. The biggest feast of all was for the wedding of two students who were married while living at the house.

Having student boarders also brought more social contact between people within the house and people outside. However, other factors also contributed to the increased social contact between those inside and outside. To begin with, this was now the period when the influence of the Black Power Movement was significant among many people in Britain. Dusty became more interested in activities outside the home. In particular, he developed a strong political interest in the communist party, and became a member. Through his affiliation with the party, he developed an ethnically diverse group of friends who visited the house, and whose homes he also visited.

Additionally, two other 'mixed families' moved into the neighbourhood, becoming close friends with the Smiths. Their children also attended the school nearby. It was also during this period that Polly and Mark's school amalgamated with another school, which resulted in 'an influx of people of colour'. Consequently, more social mixing took place in the school, and Polly and Mark developed a diverse group of friends. However, these friendship affiliations did not always occur without resistance or disapproval from some parents and others in the general public. Such disapprovals were further fuelled by the incidents of the American Civil Rights Movement during this period, and the racist slogan originating from the US 'If you are not white, you are black'. Mark recalled that among his group of friends, he had 'a very good white friend', and often when they were out together: 'we would get into problems with white guys, because they didn't like me being with him, or we'd get into problems with black guys, because they didn't like him being with me. So I used to get in lots of trouble because we were tight'.

By this period, 'black clubs' and 'black music' had also become more popular, and both British people and African-Caribbeans attended the dances. Polly often went with her English girlfriends, whose parents tolerated their daughter's friendship with her, but disapproved of their association with 'black boys'. This confused Polly who found the situation 'insulting'. She couldn't understand why association with her was fine, but association with her 'black friends' was forbidden.

Increased contact between individuals inside the house and the wider community also occurred as a result of Dawn's strategy (mentioned earlier) of ignoring racism. Over time, the neighbours became friendlier, and Polly and Mark became more relaxed about going to the park and playing with other children. Additionally, the local pub owner had left, and Dusty had developed a friendship with the new owner. Through

regular visits, he also developed a relationship with the other regular pub attendees in the neighbourhood, where he was known as the local comedian – a role he adopted possibly as a form of resistance/opposition to racism.

### **Crises in the family: The 1970s and 1980s**

This social mixing between individuals inside and outside the house intensified into the 1970s. The 1970s also evinced major crises and changes within the Smith family. To begin with, Dawn's mother Sue fell ill. When her doctor suggested she be placed in a special care home, Dusty protested, insisting that: 'She is not going into no home, she is coming home with us!' They took Sue home and gave her the room above their own bedroom, with its own bath and a television so that she could watch her regular sports programmes. Dusty and Dawn became her main care-givers. Her grandchildren Mark and Polly visited her in the mornings before setting off for school. In the evenings, they sat with her for a while and talked about what they did at school that day as they held her hands and sometimes read the Bible with her. She also had regular visits from her sons and their wives. Because her door was always left open, she had constant visits from everyone in the house – including the students who called her 'Nan'. She was also given a walking stick that she used to knock on the floor when she was alone and needed help.

After nearly a year of being very ill, Sue died on Dusty's birthday with her head resting on his arms. Her grandson Mark recalled the day she died:

The night she died, we were all up there [in her room] sitting down. It was late, I think it was probably in the eleven thirty or twelve o'clock hour, and me and my Uncle Toby, we were holding her hand, while my father had her head in his arms. We were holding her, and she just opened her eyes, and she looked around, then she just closed her eyes, and she was gone. My uncle was at her side bawling, and I just sat there and held her hand, because I felt it. I loved her, and that was a bad day.

Sue's death upset everyone in the family. However, for Mark, who had just completed high school and was uncertain whether or not he wanted to go on to further education, her death could not have come at a worse time. He became 'so upset and confused' that he left home and went to live in the West Indies, where he stayed for a while.

The early 1970s found Polly still living at home. It was during this period that she met and married Geoff, a second-generation African-Caribbean and the father of her four children. For the first few months of their marriage, they lived in the big house until they found a flat of their own. Polly had been working as a helper in Dawn's guesthouse after she finished school, and she continued to do so for a while after she got married.

It was also during the early 1970s that Dawn and Dusty went on holiday for the first time to Jamaica. Their visit lasted for a couple of months and, while they were away, Polly gave birth to her first child, and continued to run the guesthouse. Mark also returned to England while his parents were away and, since there was no space for him in the house, he moved in with Polly and her husband and baby in their flat. In the meantime, Dawn 'fell in love' with Jamaica and, in particular, with the house and property where they were vacationing. She convinced Dusty to go back to London, sell the big house and relocate there. It took them a couple of years to sort out their affairs in London before they moved. Eventually they gave up the guesthouse business, sold the big house and bought the house they had visited in Jamaica. In the meantime, however, another crisis developed in their family.

Shortly after Mark arrived back in London from the West Indies, he met Sarah and, within a year, they had a daughter Nancy (see Figure 3.1 at the end of this chapter). Although they did not live together, they had a tumultuous relationship. For numerous reasons, Sarah was deemed an unfit mother and – without having to go through the legal procedure of adoption or fostering that is the norm in Britain – Dusty and Dawn strategically convinced social services to grant them guardianship of their granddaughter. Thus, we find Dawn now caring for her grandchild, just as her mother had cared before for her daughter Polly, albeit for different reasons. Dawn was a fit mother but, because of discrimination, was unable to raise Polly in their rented house and therefore had to send her to Ireland to be with her grandmother. Caring for grandchildren is a common informal practice among Caribbean families – called 'fostering' or 'child-shifting' in the anthropological/non-legal sense, whereby a dependent or minor child is relocated to a household where neither of its birth parents resides (see Besson 2002a: Clark 1999 [1957]; Goody 1975; Gordon 1996; Olwig 1981) – but in Britain, such practice is usually done through legal procedures if at least one of the child's parents does not reside in the grandparental home. However, these British and Jamaican grandparents managed to bring up their grandchild without the formal legal procedures – itself another form of adaptation. Furthermore, after selling the big house and relocating to Jamaica, through a simply phone call, Dawn

and Dusty were granted permission from social services to take their granddaughter, Nancy, to Jamaica with them.

From all accounts, the move to Jamaica was a big event that ruptured the family and created emotional conflicts that have continued into the present. To begin with, Dawn and Dusty's departure resulted in the dispersal of the close kinship network that had developed inside the house. Without the big house where family and friends had been brought together, family socialisation on a large scale ended. Polly, who by now had two small children, saw her uncles and their families less, but she still had her Auntie Clara and her cousins, Leah and Sam, and they became her main support network. Dawn and Dusty kept in regular contact with their family back in London through phone calls and letters. They also had visits from various family members and friends at different times, and their son, Mark, eventually left London to live with them for a while.

Even with regular contact, Polly felt the loss of her parents greatly. She would have liked to have had their practical and emotional support while she was raising her children. She wished her children had close emotional bonding with their grandparents while they were growing up – especially since her husband's parents never lived in Britain. Life became particularly difficult for Polly when her marriage ended. She recalled this period as the 'worst time in my life'.

When I left my husband, I had four children and no support. My parents were not in this country. I ran away from him [Geoff], and I was frightened. We [she and the children] were living in a hotel in [North London] in one room. I was working at the time, but I had to give my job up because I couldn't cope. I started drinking little bottles of vodka to get me to sleep in the hotel every night... I'd think "I can't keep doing this". I lost loads of weight, and all my hair fell out. It was horrible!

Feeding the children wasn't a problem. Because I was a single parent, I was getting income support. So I'd get a giro [a cheque]. The state was paying for the hotel, and in the hotel, they'd give you breakfast. So I had no outgoing bills. I was frightened, and living very kind of – I didn't have all my possessions with me – I just used to phone Leah every night and tell her what was going on – that's my cousin ...Then eventually, we got moved from the hotel into a hostel, and we were there for about a year... That really was the most horrible time in my life, and I needed my parents, but they had left.

Throughout this crisis period, Polly's main support system was her Auntie Clara, her Cousin Leah and Leah's family. Dawn and Dusty

remained abroad for twenty years. Polly eventually moved out of the hostel, did various jobs, went to university, earned a degree and single-handedly raised her four children. During this time, London had also become more ethnically diverse and, according to her, the feeling she had of being 'different' when she and her brother were growing up had gone. The neighbourhoods in which she raised her children were 'quite socially mixed: Greek, Asian, quite a few black people. There were plenty of other children for them [her children] to identify with, and we mixed with everyone'.

Polly's children's memories confirm this impression of wider change. They also attended schools that were 'ethnically mixed'. Her daughter, Anna, recalled how largely unaware she was of ethnic differences among her peers, and was only reminded at times when some children in the playground used terms such as 'golly-wog' or whenever she visited other people's homes and noticed the different food smells. But, she said, 'overall, there was nothing stopping you from being friends with anybody'. In primary school, she had an ethnically diverse group of friends. Things changed drastically for Anna, however, after she finished primary school and won a scholarship to a fee-paying private girls' school in the mid-1980s.

The first day she arrived, she was surprised to learn that, in the whole school, there were only four 'black girls' including herself. Anna's experience in the 1980s was very different from her grandparents' experience in the 1950s or even her mother's experience in the 1960s. Unlike Dawn and Dusty and their children who had suffered colour prejudice, Anna was never made to feel excluded. If anything, she had become 'a novelty' among her peers. The issue for Anna was about class – an issue that, according to her, became hers but not her peers'.

Anna came from a working-class family and her parents could never have afforded to send her to this school, let alone pay the cost of extra-curricular activities. Furthermore, it was while she was at this school that her parents separated, and Polly was shifting around in temporary one-room accommodations with her siblings. The other girls, most of whom had been in that school since primary, were, according to Anna, 'upper middle-class girls, who had lots of money, who lived in huge houses, and had piano lessons, tennis lessons, tutors, went on holiday every year and didn't want for anything'. The knowledge of this, and the fact that Anna couldn't afford the things that these girls had, bothered her for the whole time she was at the school.

I felt like I didn't like them, because they didn't realise how lucky they were. They had no idea how privileged they were. They took it all for granted, and I felt that because of that, I just didn't like them as people.



Anna did make friends with the girls at her school, although she found some of these friendships ‘strained and difficult, lots of ups and downs’. The difficulty was not so much to do with what the other girls thought about or did to her – although she felt that a few ‘undermined’ her academic ability – as much as it was her inability to overlook the class difference between herself and her peers. Despite these challenges, she tried to integrate into the school environment. She excelled in sports and drama, did not cause trouble and became the school comedienne whose peers saw her as the ‘big character’ who made them laugh a lot. In her view, this was her strategic mode of avoiding potential discrimination from her peers.

When Anna finished high school, she won a scholarship to the London School of Economics (LSE). At LSE, there were a large proportion of foreign students who, according to her, tended to ‘stick together’ in their own ethnic groups. By now, Anna, from a third-generation of African-Caribbean and British parentage – who had been socialised among people from various ethnic backgrounds in her family, in her neighbourhoods, in her early schools and from the clubs she attended – found the notion of socialising among people from one ethnic group ‘strange’. So strange was it to her that, even though there was an African-Caribbean society at her college, she didn’t become involved because ‘the students tended to be from the Caribbean, and we weren’t the same’. The notion of being ‘Caribbean’ had no real significance for her, except from the stories she had been told by her relatives from her grandparents’ generation. Her friendship network was ‘very ethnically diverse’. These were the people with whom she felt she shared common values and interests. Her values were influenced in part by her parents’ values – which were already shaped in part by British social values – but in a large part also by the British environment in which she grew up, both at school and in her neighbourhood.

### **The family reunites in the 1990s**

The 1990s saw the physical reuniting of the Smith family, and also the addition of more biological as well as non-biological relatives. After Dawn and Dusty left London in the mid-1970s, the family in London had grown only with regards to Polly’s children. Mark had followed his parents to Jamaica and, while there, he married a local woman with whom he had two more children. Back in London, through Polly’s efforts, other members had also been added to their family. Shortly after she and Geoff separated, Geoff developed a relationship with another woman, Karen. Together they had a son, Lloyd, but shortly afterwards they separated. When Polly found out about Lloyd, she contacted Karen

and invited her and her son to become members of her family. This was important for Polly who believed that, despite the issues between Geoff and the mothers of his children, the children should know their siblings, and be involved in each other's lives. This inclusive attitude again shows Caribbean influence in the development of creolised kinship attitudes in these London families. So although Geoff was no longer actively involved in the lives of his children nor their mothers, the mothers and the children had become a very close unit, participating in family events together and providing emotional support for each other.

By the late 1990s, Polly's daughter Anna had fallen in love, and moved into her own home with her boyfriend Carl. Carl was born and raised in London of a French mother and an English father. The family extension on his side is relatively small, including only his mother Kitty, her partner John and Carl's Aunt Mildred (his father's sister). Carl grew up as an only child. He has two stepsiblings by his father, but has never met them (his stepsiblings). His mother is also an only child, and his father had two sisters and a brother. His grandparents on both sides had died, as had his father. Before his father died, he had become estranged from all his family – except one of his sisters – due to ongoing family conflict. So although the family lived geographically close when Carl was growing up in London, family relationships were non-existent. As a result, except for his Aunt Mildred, he does not include any of his father's relatives as members of his family.

For Carl, being part of an extended family was a first-time experience. He became incorporated into Anna's family with great ease, largely because, as with the majority of her family, he too had been socialised in Britain – specifically, in London. As with Anna, Carl also socialised with people from different ethnic groups in school and at work, and also made significant friendships with individuals from these groups. He developed a wide interest in music and food from his friendship affiliations. Culturally, therefore, he and Anna – and other members of her family – despite coming from diverse British and Caribbean backgrounds, share more in common in terms of attitudes, beliefs, values and interests than their culturally diverse parents or grandparents would have twenty years ago. He often got together with Anna's big brother for 'musical sessions' and at family gatherings, where he would contribute greatly to the food preparation. His mother Kitty and her partner have also been incorporated into the Smith's extended family. Although Kitty does not live in London, there are regular get-togethers between the two families, and the two mothers visit each other independent of other family members, stay in each other's homes and have holidays together.

The physical reuniting of the Smith family happened when Dawn and Dusty returned to England in the mid-1990s. After living in Jamaica for twenty years, Dawn returned to have surgery, accompanied

by her granddaughter Nancy whom they had raised. While she was recuperating, Dusty flew to London to be with her. Shortly after he arrived, he fell very ill and, from the nature of his illness, it became clear that it was more 'sensible' to remain in London than return to Jamaica, their home for the last twenty years. Thus, they once again found themselves uprooted from a life to which they had become accustomed. As an elderly couple, they had to begin a new life all over again, as they had done when young adults 45 years earlier.

For the first few months, the couple and their granddaughter, Nancy, lived with Polly and three of her children in a four-bedroom house. During this period, there were endless negotiations and adaptations, both practical and emotional, among the family, in order to accommodate to the new situation into which they were all thrust. However, such adaptations or compromises did not bring lasting solutions. Not only were there issues arising from the gap between the three generations living together, but there were also differences in value systems. To begin with, although Polly's children knew of their grandparents and their cousin Nancy through visits and photographs, the geographical distance meant that they had had no major influence in one another's lives. To the children, family only had an associational value where their grandparents and cousin were concerned. Emotional bonding was something that could only develop over time.

Secondly, a clash of values often occurred between Dawn and her daughter Polly. Dawn had grown up in a family where there were no strict gender role divisions – because her father died young, she and her brother left school early to work and help care for her family. However, she had raised her family with divided sex roles, which was common practice among Irish families in Ireland (see Arensberg & Kimball 1968; Jackson 1963). For example, while Polly was expected to help with domestic chores, her brother Mark was excused from doing such chores. But as a single working parent, she had not transmitted the values Dawn taught her in the same manner; she didn't feel that they suited her family situation. Instead, she raised her sons and daughters without role division in their responsibilities. Additionally, she has replaced the strict forms of discipline that her parents practised with milder forms of discipline, including much more talking and reasoning with her children.

Dawn found the manner in which Polly ran her household difficult to observe without intervening. She felt that Polly's form of discipline was 'much too soft'. Hence, conflicts occurred between not only mother and daughter, but also between grandmother and grandchildren, and this delayed the bonding process between Dawn and her grandchildren even more. For Dusty, on the other hand, bonding with his grandchildren took place much earlier and with greater ease. He avoided

involvement in the running of Polly's home. He became the family comedian, which, according to him, was 'my way of fitting in, letting my daughter run her family the way she see fit. After all, she wasn't harming the children'. Dusty's behaviour was a form of adaptation and accommodation to a situation that he felt was beyond his authority.

After a few months of living with Polly, when it became clear that Dusty would never completely recover from his illness, the couple had to make drastic functional adjustments in their lives. The first stage was to find accommodation. Having uprooted unexpectedly from where they had settled, leaving all their material possessions behind, they were now reduced to depending on the state for accommodation and income support. They were given a one-bedroom flat by the council, and they moved in with their granddaughter Nancy. They received other forms of practical and emotional help and support from Polly – who lived nearby – Dawn's two brothers and their families, her fictive sister Clara and her daughter Leah. Their old friends from the big house – who were still alive – periodically dropped by to play cards and watch sports with Dusty. Dawn went out to work as a cleaner to supplement their income. Granddaughter Nancy also got a job and contributed to the running of the home. She soon got married and, by the end of the 1990s, she and her husband Tom had two children.

### **Into the twenty-first century: Endings and new beginnings**

The year 2000 found Dawn and Dusty still living in London with no resources to return to the home they had left in Jamaica. In this century so far, the family has experienced sorrows and struggles, but also some joys. It began with, Dawn's fictive sister Clara dying, which brought great sadness for the whole family. A few family incidents happened during my fieldwork, and I observed (and sometimes participated in) the family *doing* kinship firsthand. The first was Dusty's death.

A couple weeks before Dusty died, he was hospitalised. During this period, I maintained regular contact with the family, visited Dusty in the hospital a few times and observed the flow of other members of his family and friends who visited him. On the day he died, Dawn's brother John and her grandson-in-law Tom took care of all the funeral arrangements. The day of the funeral was a day of mourning, but it was also a great reunion. After the ceremony, everyone went back to Polly's house for what turned out to be the 'biggest party' Dawn could remember since she and Dusty last hosted the wedding party for her students in the big house over 30 years before. All their blood relatives were there, including Dusty's two nephews who had been estranged from the family, their relatives through marriage, some of Dawn and Dusty's surviving friends

from the 1960s and their children. Friends and family also came from abroad. Polly's house was spilling over with people. There was a massive quantity of food, a mixture of various Caribbean and European cuisines, which were prepared primarily by Polly's son-in law Carl and Dawn's grandson-in-law Tom. Their son, Mark, pre-selected Dusty's favourite music, and there were men in their seventies dancing with the energy of men 40 years younger. If a stranger had walked in from the street, they would never have imagined that the event was in recognition of a death. This sad event became a celebration of life, old memories and family reunion. It was a classic example of mixed sociability across generations both in terms of the family and friends who had come together as well as in the kinds of food consumed.

There were other events that I attended where I observed the Smith family kinship in action, such as the christenings of Dawn and Dusty's grandsons, Sid and Delroy (children of their granddaughter Nancy and her husband Tom), as well as Polly's daughter's marriage to Carl (a white Englishman). Anna and Carl's wedding was particularly striking not only because of the way it brought the family together in celebration, but also because their union became a 'bridge' that reunited Anna's father with the rest of the family. When Anna's parents separated – while she was still in her early teens – Geoff maintained very minimal contact with the family, and his relationship with Anna was non-existent. When she became engaged to Carl, she still had not developed a close relationship with her father and therefore did not tell him of her engagement. However, he was told of the engagement, which he disapproved on the grounds that Carl was the 'wrong colour'. He phoned Anna's home and left threatening messages on the answering machine for Carl.

Eventually Geoff and Carl met and, after a short period, grew comfortable with each other. They even forged a close relationship, partly through their shared interest in music and home renovations. They spent many hours renovating the couple's home, during which time Geoff confided in Carl about many things including his marriage and eventual separation. Seeing the closeness between her father and her partner was 'quite emotional' for Anna, and she decided to forgive him for the past, and 'reforge' her own relationship with him. In the event, Carl became a kind of link in the relationship that developed between Anna and her father.

Two years had passed since Anna and Carl became engaged, and they decided to get married. For Anna, it was very important that both her parents participate in her wedding celebrations. She invited her father to give her away on her wedding day. However, because her parents hadn't had the most amicable relationship since they separated, she and Carl devised a strategy whereby they chose a place in the Caribbean

that was 'neutral territory' for everyone. Therefore, everyone needed to adapt to the new environment in a cooperative manner. They chose a French Caribbean island where neither parents had ancestor connections and where the language and the food were different. They rented a large cottage where everyone stayed for two weeks. Because of economics, only Anna's parents, her brother and sister, Carl's mother and her partner and Carl's best friend – who was also his best man – went to the Caribbean for the wedding.

Their strategy, according to Anna and Carl, turned out to be a 'brilliant experience'. For example, Polly and Carl's mother Kitty prepared food together, shopping for groceries in the local stores and markets, and alternating the cooking with Geoff. Kitty's other role was to maintain a certain level of ease and friendliness between Polly and Geoff through humour. From various accounts, everyone had a 'good time', and Anna felt that her strategy succeeded in 'bridging the gap' that had developed between her father and the rest of the family. Additionally, this event illustrates a creative example of social mixing that transcends racial and national boundaries.

Upon their return, the couple held a reception in London, which included all their family and friends who were unable to attend the wedding ceremony in the Caribbean. I was invited, and again had the opportunity to see the family *doing* kinship. It was a large event with a very diverse food selection – Caribbean, Indian, Chinese, British – all prepared and served by various family members. In attendance was a whole range of kin, from the four generations of Smith blood relatives, to half-blood and non-blood relatives such as Polly's ex-husband's son Lloyd, and his mother, Karen, her fictive cousin Leah and her family, along with a host of other fictive kin and friends. Everyone seemed to know each other, and the newlywed couple looked very happy as they moved around, socialising with everyone. As the event came to a close, the hall was cleaned in what seemed like a flash, with guests participating in the clean-up activity.

During my fieldwork in 2002-2003, the Smith family gained another addition with the birth of Polly's grandson Toby. Polly's son Joe had the baby with a 'friend', Sheila, whom he felt 'tricked' him into getting her pregnant; Sheila is an older woman who 'desperately wanted to have a child' (see Figure 3.1). As a result, Joe has been unhappy about the situation. Although Sheila has taken some responsibility for her pregnancy, and is economically and emotionally capable of taking care of the baby, Polly – who is very proud to be a first-time grandmother – has moved forward to become a very active grandparent. She has taken the baby and Sheila into her family, and has gone to meet Sheila's family in Ireland. Baby Toby's christening was another event that brought the Smith family and Sheila's family together.

### The Smith family and kinship network in 2003

The Smith family today is not only extensive, but the family network includes a complex set of relationships, based on contact and support over time and geographical distance. Within the larger extended family, people keep in regular contact through phone calls, letter writing and regular visits. Additionally, it is expected that everyone will be there to offer help and support in times of need. However, family members also have different notions of who their closest relatives are, depending on physical time spent together and the intensity of their emotional bonding. These are the people between whom the most support is exchanged.

Now that Dusty has died, Dawn considers her closest family members to comprise: her brothers and their wives and children; her daughter Polly and her four children and grandchild; her son Mark and his wife and their two children; her granddaughter Nancy and her husband Tom and their two children and Tom's Aunt Lucy; her sister Clara's daughter Leah and her husband and child; Clara's son Sam; and a friend whom she met while living in Jamaica. Although Dawn sees these people as her closest family members, among these members, she feels closest of all to her granddaughter, Nancy, and her husband and children. Unlike her children and other grandchildren from whom she has spent periodic times apart, she raised Nancy from birth, and they have never spent any time physically apart. Additionally, unlike Polly who works outside the home and has little physical time to spend with her, Nancy is a stay-at-home mother and visits Dawn every day after her children go off to school. Nancy is also the one who shares most of Dawn's values.

Polly also makes further family distinctions within her closest kin network based on emotional bonding and mutual support. Furthermore, although she includes within her closest kin network most of the people Dawn does, there are differences between the two of them (see Figure 3.1). For example, Dawn includes the aunt of Nancy's husband while, for Polly, the extension does not go beyond Nancy's husband. Also, Polly's family network extends to include her ex-husband and the mother and child of his outside relationship, while Dawn excludes them, based on past conflicts over the issues surrounding Polly's separation. Polly indicates her closest kin as who are 'always there, who I can pick up the phone and call anytime for help, and they will be there'. These include her mother, her children, her brother, her fictive cousin Leah and her niece Nancy.

## Summary and conclusions

As with the process of creolisation, more generally, the Smith family demonstrates an ongoing, multi-dimensional, non-homogenising process of constantly recreating, adapting and negotiating social and cultural processes. This complex process results from the blending and incorporating of different racial and cultural traditions occurring between individuals over changing historical contexts and conditions. As with the interracial creolisation in Caribbean kinship that began during slavery (see Chapter 2), the Smith kinship patterns through interracial relationships, provide mediating biological and social links between different sets of families, facilitating the reproduction of different 'race'/class lines (Green 2006: 16). And as with the process of creolisation, the process of kinship among the Smiths has not occurred without conflict/struggles, resistance and accommodation. In effect, as with the West Indian creole kinship system, which began during slavery as a result of the denial of the right to establish socially recognised families and lineage among the slaves, the Smith kinship could be seen as a creole kinship system that began in 1950s racist London in the big house, as the result of a parallel denial of the right to establish socially recognised families by mainstream British society. From this type of kinship system with its fluid and complex web of interactions, emerged new forms of family relatedness involving biological as well as non-biological relatives.

The process of kinship that took place inside the big house was not solely shaped by the wishes of the Smiths, but was also moulded by constraints in British society of that time. Dusty and Dawn, uprooted (voluntarily) from their families of origin, came to London hoping to find a better life. In many ways, the social atmosphere in London was alien to both of them. Due to social sanctions against their union as individuals from diverse ethnic backgrounds, they had to create strategies to exist first as a couple and, later, as a family. Over time, not only did society have an impact on their lives, but they also influenced the people in their neighbourhood. For example, through their strategies for dealing with racism, over time some of the neighbours became friendlier, to the extent that the children began to socialise in each other's homes and in the park without disapproval.

The dynamic process of kinship for the Smith family occurred on many levels – as with the dynamic process of creolisation. First of all, in terms of uprooting and finding new ways of adapting to the context and situation in which they found themselves, this occurred three times for Dawn and Dusty. They first experienced this in London in the 1950s, where they devised strategies for coping by creating a 'multi-cultural community' in the big house, through mixed sociability of people



from diverse ethnic and cultural backgrounds. The couple uprooted a second time when they moved to reside in Dusty's home of origin, Jamaica. Here again, they had to find new ways to adapt and integrate into what was now a new society not only for Dawn, but also for Dusty. Having left his home for 30 years without returning, not only had he changed, but the society had also changed in many ways over that period. According to him, 'I was out of touch, I couldn't cope. It was not my style of country!' Most of the family he left behind had either died or migrated, and they had to develop new forms of relationships in this *new* context.

The couple's final uprooting was involuntary, and proved to be one of the most difficult times in their lives, due to declining health and lack of resources. This time, adaptations, negotiations and coping strategies were required not only by the couple, but by other members in their family. Living in their daughter Polly's home, with its limited space, proved practically and emotionally challenging for all. There were also issues concerning value systems – partly due to the differences between the three generations under the same roof – and issues of bonding and forging and reforging relationships that time had erased. Dusty and Dawn continued to find ways of adapting out of necessity, after leaving Polly's house and moving in with their granddaughter into a one-bedroom flat. Again, as has always been the nature of the Smith family, they found ways of coping through the help of their extended family – biological and fictive. Dawn went to work to supplement their income support, and family and friends provide emotional and practical support.

Finding creative solutions on 'neutral territory' as a part of doing kinship is an aspect of the Smith family that has also continued through the generations. Dawn's granddaughter Anna's wedding strategy aimed at 'bringing the family together' was successful indeed. Her father has since been reunited with the rest of the family, and has rekindled some kind of special bonding with Anna's mother, Polly. He makes regular visits to her house where he cooks meals and repairs things around the house. He has also become more active in the lives of his and Polly's two last children, who are still in university.

As with the process of creolisation more generally, the process of kinship and family relatedness among the Smith family is ongoing and flexible. Their family and kinship network began as an elaborate set of relationships over 50 years ago, and has continued on its complex path four generations later into the present. It began with blood and non-blood relatives, and has developed as such, plus a complex set of affines (relations through marriage, i.e. in-laws). For example, in the 1950s the family network began with Dawn and Dusty, their children, Dawn's mother, Dawn's two brothers, Dawn's fictive sister Clara and her two

children and, other close friends of the couple. Over the next few decades, the family network extended with the addition of the spouses of Dawn's and Dusty's siblings, the spouses of their children and Clara's children and the spouses of their friends – affinal relationships. Interestingly, during this stage of the family extension, the network did not include the families of the spouses. The reasons varied from racism to geographical distance. The wife of Dusty's brother Peter, for example, was ostracised by her own Jewish family, who could not accept her relationship with Peter, a Jamaican. The family of Dawn's brother John was also not interested in having a relationship with the Smiths. The families of the other spouses were simply not living in London – or for that matter, England – at the time so continuing close family relationships was much less easy.

The next stage of the extension generated a much more complex set of relationships and family connectedness. This is the stage during which the grandchildren of Dawn and Dusty formed conjugal relationships, and brought into the family more relationships through marriage (affinal relationships). Unlike discontinuities with some extended affines during the first stage of the family extension, during this next stage, relationships of affinity were possible for a couple of reasons. First, by this stage, the families of some of the spouses of the Smith grandchildren, like themselves, had been born and raised in Britain – more specifically in London – and were therefore living geographically close. Secondly, not only had British social attitudes changed, which resulted in some degree of tolerance towards mixed relationships such as Dawn and Dusty's, but by the second and third generations, members of the Smith family had been socialised in similar ways to their partners. Although they came together from different ethnic ancestry, over time, their values have become more similar than the values of their parents. Thus, we find that even though there might be differences and overlaps in values between generations, through negotiations and adaptations, members have found strategies – though not always suitable for all – to accommodate each other.

The use of humour/comedy as a strategy is a feature that runs through the generations in the Smith family, which might be seen as a mode of resistance and accommodation. In the 1960s we find Dusty becoming the comedian in his local pub where he was initially made to feel unwelcome because of his colour. Thus, the use of comedy may be seen as a form of resistance to racism, and also as a form of accommodation, or what Dusty himself described as 'fitting in' or 'getting into the puzzle'. In his later life, when he and Dawn moved back to England and lived temporarily with their daughter Polly, while Dawn and Polly clashed over family values and roles, Dusty avoided such conflicts, and became instead the 'family comedian', which indeed earned him closer

bonding with his grandchildren. His granddaughter Anna also used humour as a way of integrating into her all-white girls' school where, according to her, 'I wasn't a troublemaker but a big character who made people laugh a lot'. Although on the surface, Dusty's comedic tactic appears simply as a form of accommodation, it could be viewed in terms of what Foucault calls 'a plurality of resistances' (Foucault 1978: 95-96). In his granddaughter Anna's case, the use of humour could be viewed as a conscious or non-spontaneous strategy set in place to avoid the possibility of later having to resist or oppose racism.

Another striking feature of the Smith family that finds parallel with the creole Caribbean family is the central role women play in making kinship. In the early stage, we saw Dawn coming forward to gain guardianship of her granddaughter Nancy from her unfit mother – albeit informally following the 'fostering' practice in the Caribbean. Later we saw Polly being progressive in making kinship through her active relationships with her ex-husband's 'outside' child and the child's mother, and her grandson's mother and her relatives. This inclusion is symbolic of the importance not only of blood ties, which has always been important to the Smith family, but also to the openness and flexibility to non-blood ties, which have also always existed within the family. Finally, in the current generation, it is through Polly's daughter Anna's efforts that her father has rejoined the family.

The extensions of kinship found in the Smith family are not common to the English kinship system, where 'the genealogical depth is shallow and the range of kinship ties narrow in its categories' (Firth 1956: 62). Neither are they common to the Irish and Welsh kinship systems, which very much resemble the English kinship system (see Arensberg & Kimball 1968; Rosser & Harris 1965). Instead, the extensions of kinship found in the Smith family are paralleled by the Caribbean creole kinship system. R. T. Smith, in illustrating the dynamics in West Indian kinship ties, stresses the consanguineal (biological) tie between the child and each 'side' of his family:

Even if the couple have never lived together and break off sexual involvement immediately, a relationship usually develops between the partners and their relatives...A child is always taken to meet the kin of his missing parent, and it is usual for the mother of the child to develop friendly relations with the mother of the baby's father. (Smith 1988: 45)

However, in the case of the Smith family, instead of the child and its mother developing a relationship with the parents of the child's father, the relationship is developed with the children and ex-wife of the child's

father. Thus even the concept of bilateral kinship is here broadened to include non-blood kin.

Such transformations in London have not been limited to the Smith family. The dynamic process of creating and recreating kinship through the social interactions and relationships that began in the big house, has spread out over four generations to mutually influence change in the wider society. For example, by the 1970s when Dawn and Dusty's daughter Polly married and moved out of the big house, the neighbourhoods in which she lived and raised her children were no longer ethnically segregated. From her account, they had a 'good social mix where everybody was friendly'. The experience of 'being different' that she and her brother had growing up in the neighbourhood where the big house was located had disappeared for her, and did not exist for her children (except for Anna's experience at her all-white school). Having overcome the experience of racism as a child, Polly herself has come to feel 'very enriched by the cultural mix' not only within her family, but also within her neighbourhood and her society in general.

For Polly's daughter Anna, as a girl, the idea of segregation and sociability within a single group of people was 'strange'. So much so, that she experienced 'a kind of culture shock' when she entered high school and realised that she was the 'poorest' student and one of only four 'black' girls in the whole school. When she went to university, she refused to join the African-Caribbean Society there because its members were largely foreign students from the Caribbean. Although she has Caribbean ancestry, having been born and socialised in London, she felt she didn't share much in common with the Caribbean students: 'We weren't the same'. Anna and her white English husband, Carl, believe they are 'culturally very similar'. They believe that they and their peers are of 'a culture that can assimilate' more easily than the culture of Dawn and Dusty's generation. This is evident in their shared tastes in food, clothing, music, etc., as well as in their values and attitudes towards life – despite their different skin colour.

In sum, this chapter shows the process of kinship and family relatedness in one family, the Smiths. It demonstrates aspects of the creolisation process: shifts in contexts, shifts and overlaps in ethnicity and class, the various strategies devised to facilitate accommodation, the central role of women in making kinship, as well as continuities, modifications and discontinuities in family practices and values. Far from being fixed, the Smith kinship system is an ongoing and dynamic process of rupture – voluntary and involuntary – and integration, incorporation, adaptation and accommodation. It is filled with experiences of conflict and joys, and the ongoing creative culture-building strategies developed by its members. The chapter that follows addresses some of the same themes but, in particular, looks more in-depth at family

relationships between biological and non-biological relatives. It explores the significance of children (siblings, nieces, nephews and grandchildren) in the forming of links between families, and across generations, again in one family: Gobi's family. It also looks at the significance of women as maintainers of the kinship network – a theme running throughout the book – partly in order for their children to have connections with their wide family network.

**Key to Figure 3.1**

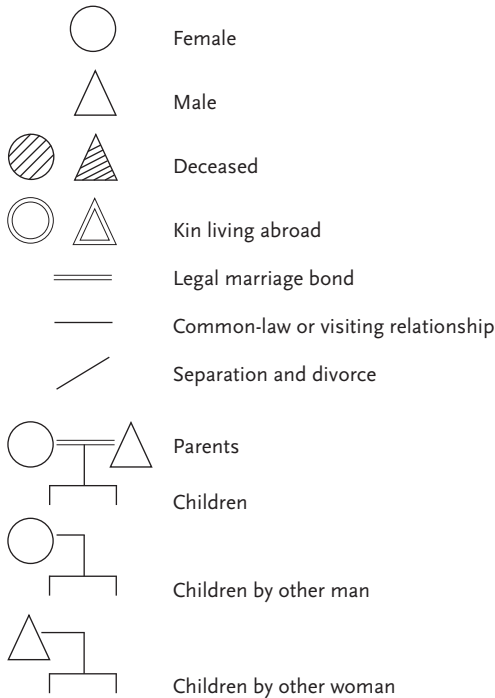
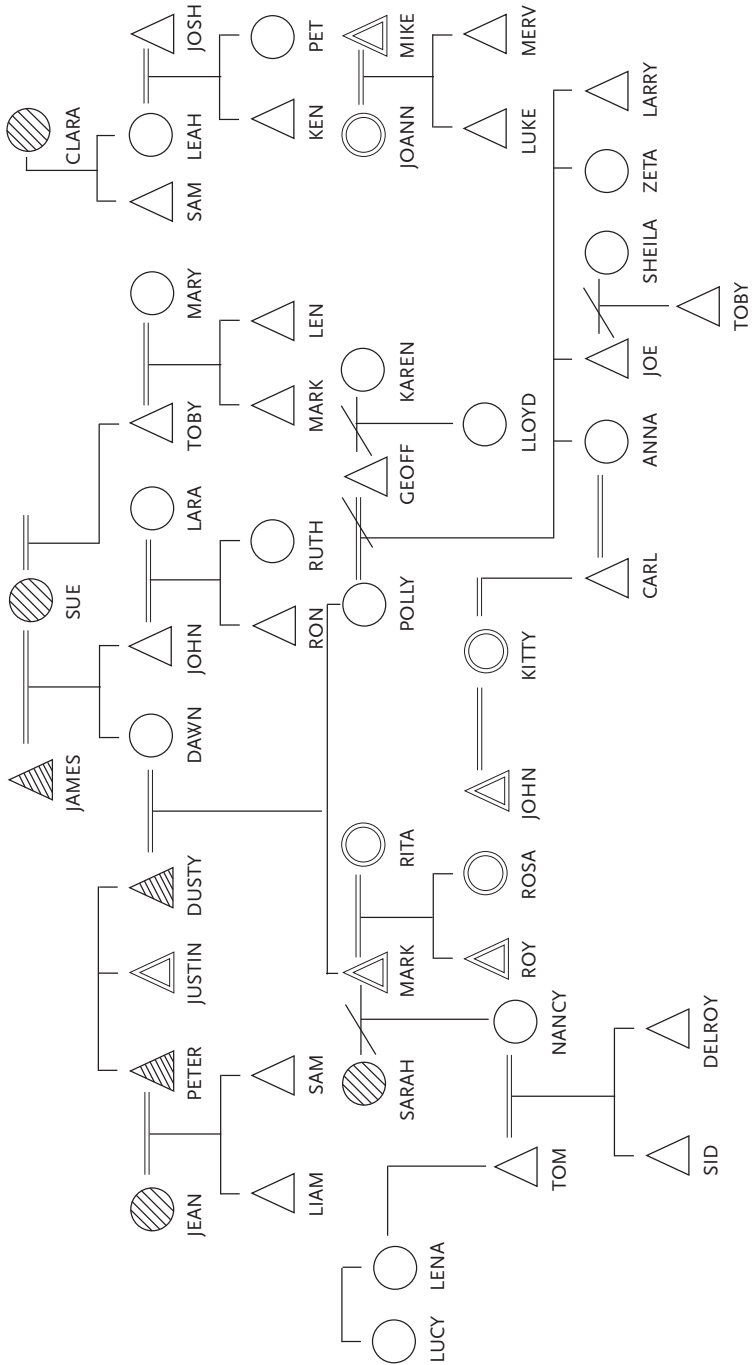

Figure 3.1 *The Smiths: Four generations*



## 4 Extending the links: The agency of women and the significance of children in the creation and maintenance of kinship

It goes on and on and on as it grows and grows... All the children are my children. They all belong to me, and I have the same responsibility to all of them. Part of that responsibility is to keep them together. (Gobi Clark, reflecting on her extended family)

In the last chapter we saw how people who come together from different ethnic and social-class backgrounds defined their family relationships based on the amount of physical time spent together, the degree of emotional bonding and the extent to which help and support are exchanged. We noted the emergence of an approach to doing kinship among the Smith family that is akin to Caribbean kinship relationships. This includes the incorporation of biological as well as non-biological relatives into the kinship network. This chapter is concerned with relationships in a family and, again, the incorporation of biological and non-biological relatives into the family network. It explores the crucial role of women in the maintenance of the kinship network. It also looks at the significance of children (siblings, nieces, nephews and grandchildren) in forming the links between families.

As with the last chapter, this chapter will focus on one family, that of Gobi Clark. It will explore dynamics that are not particularly unique to this family, as there are similar examples running through other families in the research. Nevertheless, I again caution against generalisations, as one family's experience and handling of the same phenomenon might be different from another family's. However, by focusing on one family I am better able to draw out some of the complexities involved in these families. The first part of the chapter will draw on various family members' accounts of family practices and relationships between generations. This sets the stage for the second part on what I call 'current family relationships', which concerns the practices I was able to observe during my fieldwork. It was only through this combination of family stories and observed practices that I felt able to grasp some knowledge and understanding of the manner in which kinship and relatedness developed in this family.

## Gobi's family background

Gobi comes from a white English family who originated in the north of England, where she was born in the mid-1950s (see Figure 4.1 at the end of this chapter). Her parents moved the family (she has one older sister, Misty) to a large estate in the countryside just north-west of London when she was five years old, but remained in contact with her northern grandparents. Her father Tony worked at a local school for disabled children as a teacher, and her mother Judy, as an assistant. The move meant that, for the first time, Gobi and her sister came into contact with people from different ethnic groups.

However, within five years of moving south, first Gobi's father Tony died and, soon afterwards, her mother also died. The two sisters went to live with their Aunt Vicky – who was actually their father's cousin – in north-west London. Aunt Vicky and her husband Nick had four children and a very large, isolated house. Gobi and her sister found living with their aunt 'very strange and restricting'. According to Gobi:

I was an outdoor child who had grown up in a school for handi-capped children. I went to school, I came home, and I had a family of a hundred disabled kids. I climbed trees with kids with no arms and legs, and ran down hills with them in wheelchairs. Therefore, living with Aunt Vicky and her family was not my cup of tea.

Gobi's sister Misty remained with their aunt for a year before leaving for university. At sixteen, Gobi left her aunt to work as a cleaner in a hospital, where she also lived in the residential housing. At seventeen, she got a job as an auxiliary nurse at the same hospital.

## First husband Headley

Gobi met her first husband Headley in school at the age of fifteen while she was living in London with her Aunt Vicky. When she began work as an auxiliary nurse, she left the hospital residence, and went to live with Headley and his family (Headley was still living with his parents). Like Gobi, Headley's family originated in the North of England (see Figure 4.2) but, unlike her 'middle-class' family of origin, Headley's family was, in Gobi's terms, 'working-class'. In London, Headley's parents Rita and Dennis lived in a council house, and when Gobi moved in with the family of five (Headley has a sister and a brother), she recalls feeling 'more at home than in the big house that I lived in with my aunt, which was just a house, not a home'. She felt Headley's



parents were like 'substitute parents', and she developed a close, lasting relationship with his family. After working two years as an auxiliary nurse, she travelled for nearly two years, then returned and enrolled in a nursing course. Upon finishing nursing school two-and-a-half years later, she and Headley bought and moved into their own home. They soon became married and had two children, Laura and Rupert.

### *Family relationships*

During this period, Gobi and Headley remained in regular contact with Headley's family. According to Gobi, his parents Rita and Dennis were the 'ultimate grandparents who adored the two children, Laura and Rupert'. However, within three years of marrying, Gobi and Headley divorced. According to her, after she had her first child, Headley 'demanded' that she quit her job and become a 'full-time mother and wife'. After their second child was born, Gobi fell ill and their relationship became conflictual to the point of divorce. As a consequence of her illness and lack of work, Headley was granted custody of the children on the condition that they spent the weekends with Gobi.

Very soon after the divorce, Headley got remarried, to Esther (see Figure 4.3), and they moved with the children to the countryside outside of London. Gobi continued to maintain a 'fairly good' relationship with Headley's family, and she paid them occasional visits on weekends when she had the children. Family get-togethers on birthdays and on high holidays, such as Christmas, continued with Headley's parents and his two siblings Patsy and Mark. Family relationships with Gobi's family of origin also continued to some degree. By now her sister Misty had married an Italian and moved to live abroad. Before moving abroad, Misty and Gobi 'got caught up' in a conflict with their northern family and, as a result, Gobi hasn't been in contact with those family members since. She took the children on regular visits abroad to see her sister Misty and her new family, and she continued to visit her aunt in London.

During the first three years of living with Headley and his new wife, his daughter Laura became chronically ill and was hospitalised with a suspected stomach condition. After repeated examinations, it was decided that Laura was 'making herself sick' and that the best place for her was to be with her mother. Hence, she went back to live with Gobi when she was eight years old, and 'has never set foot in her father's house since'. Her brother Rupert also moved back to live with Gobi in his mid-teens.

## Life with partner Randall

Soon after the divorce from Headley, Gobi met her second partner, Randall, who at the time ran a business as a music retailer. The couple met at a musical event, where they were introduced by a mutual friend. Randall's family originated in the Caribbean, and his parents Angela and Richard migrated to England in the early 1960s (see Figure 4.4). Before migrating, Angela and Richard had four children in the Caribbean. A few years after they arrived in England, they sent for two of the children, Randall and his brother Phil, leaving two behind, one of whom later migrated to Canada. While in England, Angela and Richard had a daughter, Phyllis. In England, Richard worked for the post office and Angela did manual labour until they retired. Angela died in 2000 and Richard is still alive.

### *Family relationships*

Shortly after they met, Gobi and Randall established an intimate relationship, but they lived separately while visiting each other's homes regularly. After Gobi and Randall came together, relationships with her aunt and her sister changed. According to her, her sister Misty (who had been living in Italy and with whom she and her first two children previously spent holidays), refused to 'accept or accommodate' Randall: 'I wasn't suited after that, cause I was now with a black man. So I've been cut off from her, no contact'. Gobi's relationship with Aunt Vicky continued, but to a lesser degree than it was before she met Randall. To begin with, visits to Aunt Vicky's were less frequent, and they usually involved only Gobi and her children. She recalled the only visit to her aunt's where Randall was present:

We were invited to a family tea, and Randall came with me Laura and Rupert, and she'd [Aunt Vicky] also invited the vicar for tea. We were put in another room to eat, because it was assumed we couldn't converse with the vicar for tea...So that was strange, because Randall, who was brought up in a completely churchy family, probably could have quoted every verse in the Bible better than the vicar could have done. Certainly better than my aunt and sister could have done. It was difficult.

Randall never visited Aunt Vicky's again, nor developed a relationship with her and her family.

Gobi's relationship with the family of her ex-husband Headley had also taken a downturn, because 'they disapproved' of her relationship with Randall. However, Headley's parents Rita and Dennis continued to

maintain an active relationship with their son and their grandchildren, who were at the time living with Headley.

### *Living together*

Randall eventually moved in with Gobi and her two children Laura and Rupert. Before he met Gobi, he had been involved in a relationship with Mona (who was also of Caribbean origin), and they had two children, Christa and Randy (see Figure 4.4). When Randall separated from Mona, they still shared custody of the children. Shortly after he moved in with Gobi, Mona was convicted for an offence and was deemed an unfit mother by the social services. Hence, Randall brought Christa and Randy, who were then eight and four, respectively, to live with him and Gobi. When it became clear that Mona would never be allowed to have her children again, Gobi decided to keep them. In her words: 'It was either they went into care or I kept them. So I kept them! I inherited them and brought them up. I became their mum'. And this she was able to do informally, without the involvement of social services, suggesting a creolised form of family arrangement in a new context where such arrangements usually involve the law.

### *'My family comes as a unit or not at all'*

After Randall and his two children moved into Gobi's home, family relationships with her Aunt Vicky became even less close. Vicky continued to invite Gobi's two children to her house, but her two 'inherited' children by Randall were never invited. Hence, Gobi's nuclear family was never invited as a 'complete family'. According to her, her aunt 'never accepted my two black children when I took them on'. Gobi was not satisfied with the dynamics that had developed among her family, but decided that she would 'put up with the situation, given the fact that they are my only relatives close by'. Therefore, she continued to allow her first two children to visit her aunt whenever they were invited. The dynamics of their relationship changed even more when Aunt Vicky's son Raymond got married, and Gobi and her first two children were invited to the wedding, but not her partner Randall or the other two children. Gobi refused to go or to send her children Laura and Rupert on the grounds that 'my family comes as a unit or not at all'. This situation created a conflict between Gobi and her aunt and, for a period of time, there was no contact between the families.

Meanwhile, Gobi's relationship with her ex-husband Headley remained non-existent. Their daughter Laura only saw her father whenever they met at her grandparents' home for Christmas and other holiday celebrations. Their son Rupert continued to visit his father, though

he never developed a close relationship with his step-mother Esther. Although Gobi had become 'somewhat remote' from her ex-husband's family, his parents Rita and Dennis remained very active in the children's lives while they were living with Headley. When Laura and Rupert moved back to live with their mother, Headley's family rebuilt their relationship with Gobi, welcoming all her children. Consequently, visits to Rita and Dennis included all four of Gobi's children and, at Christmas and birthdays, presents were distributed equally among all four children. Additionally, all four children call Rita and Dennis 'Nanny' and 'Grandpa'.

Relationships with Randall's family are also strong and more extensive – partly because it is larger. Randall's mother Angela, who was a 'strong Baptist', took all four children to church on Sundays while she was alive. After church every Sunday afternoon, the rest of the family went to Angela's house for what they all described as 'the Sunday dinner ritual' of rice and peas and chicken. To all the children, Angela was 'Grandma' and, if any of them misbehaved, Rupert recalled how they would all be 'told off' in the same manner by Angela.

Family relationships with Randall's family also extended beyond Britain with relatives in the Caribbean and in North America. There are regular contacts via email, letters and phone calls. Randall, Gobi and all the children have been to the Caribbean to spend time with Randall's relatives. His sister in Canada visits the family in England regularly, and sends presents to all the children.

#### *Gobi and Randall's birth child*

Fifteen years after Gobi and Randall came together as a couple, she became pregnant, and during the pregnancy they parted. According to her, she 'simply became tired of his drinking' and, one day after she came home and found him 'passed out' on the sofa, left him there and she moved out. Gobi took all four children, continuing to raise Randall's two children without legal intervention while their birth mother was unable to care for them. In her view:

By now they were my children. I had brought them up. He had a drinking problem and there was no way that I was going to leave them with him. They call me mum, and all my children get on like sisters and brothers – they play, they fight. They call each other brothers and sisters.

Thus, with help and support from Randall's relatives, Gobi kept and raised the children as her own.

Parting with Randall, however, was only on an intimate level, because he continued to provide support for his children. He continued to visit the family in their new home, and helped the children with their homework. He also continued to do the 'manly' chores around the home such as cutting the lawn and repairing things. Additionally, he and Gobi continued to provide mutual help and support to each other. Four months after the couple parted, Gobi gave birth to their baby Julia. The children recalled how 'delighted' they were to have a new baby around, and Gobi's daughter Laura, who was eighteen years old when Julia was born, remembered feeling for the first time that her two step-siblings Christa and Randy 'were really my brother and sister because we now have the same little sister'. According to Christa who was fifteen at the time Julia was born: 'I felt like our family was different and special, because we had all the colours of people in the world in our family'.

### **Life with partner Courtney**

Two years after parting with Randall and having Julia, Gobi met Courtney at a club. Courtney's family originated in the Caribbean, and his parents had migrated to Britain in the early 1960s and sent for him a few years later (see Figure 4.5). Courtney has seven brothers and sisters all living in London. Until they retired, his father worked as a bus driver and his mother, as an office cleaner. When Gobi met Courtney, he was studying at university. After meeting at the same club a few times, they developed a close relationship and, for the first few months, their relationship developed even further, with Courtney making regular visits to her home. Gobi became pregnant very early into the relationship, and they decided that Courtney should move in with her. They lived together for a year and, according to Gobi, during that period, 'he came and went as he pleased. He'd more or less be here, then maybe Friday night he'd be off, and then you wouldn't see him till Sunday'. When Courtney decided to move his belongings into Gobi's house, she went to his flat to help him with the move, and there she saw various pictures of children on his wall. He told her that three were his children and the others were 'just family'.

Gobi soon found out that Courtney had been involved in a simultaneous relationship with another woman and, that all the children in the photos on his wall were actually his children by various women. When this information was revealed to her, she was eight months pregnant with his child. She immediately packed up all of his belongings and took them to the house where he was spending time with 'the other woman'. Gobi recalled arriving at the house where he was playing dominos upstairs with his mate. She knocked on the door and a woman

answered: “Does Courtney live with you?” I asked, and she said, “Yeah.” So I said, “Well you might as well have his washing, his bloody books, the whole fucking lot!” He comes running downstairs, and I just left them there, and never heard from him for quite some time’.

### *Trudy is born*

A month after Gobi and Courtney separated, she gave birth to their daughter Trudy. It was her fourth birth, and she had decided to have the baby at home. Courtney, who for a long time had been suffering from drug addiction, had fallen into a deep depression and was unable to be present at the birth of his baby. His brother Mathew came to Gobi’s aid, providing emotional and practical support during the birth. Mathew continued to help Gobi and the children for a few weeks until she regained her strength. Her older children also helped care for their younger sister. When Trudy was five weeks old, Courtney went to see his baby for the first time, but didn’t see her again until he came to her second birthday party. At the birthday party, he convinced Gobi that he was ‘clean’ of his drug addiction and they decided to rebuild their relationship. This time their relationship lasted for a week, after which he left. Two years later he turned up again, stayed for a week and left again. Their relationship has continued in this pattern into the present. In the meantime, Courtney has admitted to having nine other children with various women.

### *Family relationships*

Trudy’s birth created another link in the extended family network. Although Courtney maintained minimal contact with Gobi and the baby, Gobi – determined to ensure that Trudy would know her father’s family – made contact with his parents and eventually got to know his seven siblings and many of their numerous children. His family has welcomed her family, and all her children call Courtney’s parents Betty and Daniel ‘Granny’ and ‘Grandpa’. Gobi regularly took her children to visit Granny Betty and Grandpa Daniel at their home, where they came into contact with the rest of Courtney’s family of origin. Granny Betty was always ‘ready and willing’ to provide childcare for Trudy and her sister Julia whenever Gobi needed help. Courtney’s younger brother Mathew, who provided emotional and practical help to Gobi when Trudy was born, remained in very close contact with her family. Gobi became particularly close to Courtney’s only sister, whose children were close in age to Gobi’s last two children. The two women visited each other’s homes independently of other family members and the children spent lots of time playing together.

Family relationships between the other two sets of family (the family of Gobi's first husband Headley and the family of her second partner Randall) continued, and with all the visits and get-togethers between families, Gobi was often left 'exhausted'. In her words:

It got manic at times. Having a mixed family like mine is very rewarding in a lot of ways...the different food, the different attitudes to life, the many hands to help out whenever you need help. But on the other hand, it can be bloody hard work sometimes! So many people to see! Sometimes you also get burdened with the problems of some family members, and because I am a family counsellor, I am expected to contribute to a resolution. But I guess that is part and parcel of being part of any family really. Mine is just very, very large!

On the other hand, Gobi's relationship with her own family of origin changed only slightly. With her sister Misty, it remained non-existent. Aunt Vicky continued to extend partial invitations to Gobi's nuclear family. After Gobi's last two children Julia and Trudy were born, Vicky included them in family invitations so that, according to Gobi, she continued to invite 'the two white children, and now the two mixed-race ones were also invited, but not the two black ones'. Furthermore, there were the usual comments regarding how 'good' Gobi was at 'breeding', along with other stereotypes regarding her choice of partners. Nevertheless, when her first two children were old enough to travel without an adult, she would send them, and occasionally also her last two, to visit Aunt Vicky; since her 'inherited' children were not invited, however, she refused to go along herself.

Other links were added to the family network, as Courtney's children all came to know each other through the various family visits and get-togethers with his family. Furthermore, Gobi developed a close relationship with two of the mothers of Courtney's other children. Because their children were close in age, they often planned joint leisure activities with the children, including camping weekends in the countryside, independent of other family members.

### **The young adults**

Gobi returned to work when her last two last children were still babies and her four older children were still living at home. For some time, she had been living in a council flat, which was taken over by a housing association, for which she became a tenants' representative. This led to her moving from her earlier work in nursing to become a project

manager. As young adults, her daughters Laura and Christa and her son Randy moved into their own homes. However, they continued to visit their mother and their baby sisters regularly, providing care for the babies when necessary.

Laura moved into a flat with her partner Charlie, and after having her own two children, Lucy and Marcia – very closely together – she took them to her mother's home during the days when Gobi worked. Laura described the experience as 'a family daycare' where she also cared for her two younger siblings. This family daycare situation continued until Gobi's last two children were old enough to attend school. Laura has since become a teacher, working in the evenings. Her first daughter Lucy is now at primary school, and she cares for her second daughter Marcia during the daytime.

Gobi's daughter Christa went to college where she studied social work, and works as a social worker. When Christa was in her early twenties, her birth mother, Mona had another child, four-year-old Gabriella whom she was again unable to care for. Social services intervened and proposed that little Gabriella be placed in care. Christa, who was by now working and living in her own flat, negotiated with social services to be allowed to foster her baby sister. For her, the idea of her sister going into care was 'unthinkable as long as I was willing and able to help'.

No matter what stupid things my mother does she is still my mother. It is not my sister's fault that she was born. My brother [Randy] and I were very fortunate to be saved from social services and given a chance when mum [referring to Gobi] stepped in. Now that I am in a position to do the same for my sister, I would fight whatever authority it takes to keep her in the family. We are her family. Why should she be farmed out to strangers when we are right here?

Here we see a transgenerational creolised form of child fostering among extended family members, beginning with Gobi and continuing with Christa. Gabriella was nine years old when I met the family, and was still in Christa's care because both her parents were deemed unfit by the social services.

Gobi's son Randy left home in his late teens. He lives on his own and works as a carpenter. Her son Rupert went to college and trained as an electrician, doing his apprenticeship with his father Headley, who is a heating and plumbing engineer. He continues to work with his father. Additionally, Rupert encouraged his sister Laura's partner Charlie to become a building craftsman and, at present, they work together. Rupert hasn't left home and has a partner, Ruby, with whom he spends time between their two homes.



### **Current family relationships: 'It goes on, and on and on'**

So how do the links that have extended Gobi's family into such a wide network function to maintain the network? Up to this point, this chapter has described family relationships and practices as told primarily by Gobi and members of her family. The second part of the chapter will describe the family relationships and practices I observed during my fieldwork. It begins with family relationships between Gobi and her children and her family of origin, continues with the family relationships between each of her partners and their families of origin and culminates with the relationships among the children.

#### *Relationships with Gobi's family of origin*

During fieldwork, I became aware of the minimal contact and family relatedness that existed between Gobi and her family of origin. I never met any of her family from the North of England and, from what I have been told, she and her children were never in contact with any of them. I also had not met her sister nor her Aunt Vicky or any of their family. I recalled the evening I visited Gobi at home and the phone rang. She answered and said, 'Oh, hello Aunt Vicky!' Their conversation was very brief but, after she hung up, she told me that Aunt Vicky phoned to say that she was visiting a friend close by (two miles away), but due to time constraints, she was unable to come and see her and the children. However, she had something for the 'little girls', and would leave it with her friend for Gobi to pick up. 'She sings the same song all the time,' Gobi said. 'It's always the same. Only a couple of miles away, but too rushed to come by. Nothing new'. I asked her whether her sister Misty and her children had ever visited her at home. She replied with a chuckle: 'You must be joking! My sister lives a very posh life with her rich husband in Europe. I live in a council house... she wouldn't bring her children here, this [pointing to her surrounding] is all way beneath them'. Asked whether she would ever seek any form of help from her aunt or her sister, Gobi replied emphatically, 'I would rather die than go to any of them for help. They are not that kind of family to me. They are my family in name, but not in terms of what families do for each other. We don't have that kind of relationship'.

#### *Relationships with ex-husband Headley and his family of origin*

As we may recall, Headley is Gobi's first husband and the father of her first two children Laura and Rupert. After six years of marriage, Gobi and Headley divorced and their children went to live with Headley and his new wife Esther. While the children were living

there, a major conflict developed over Esther's mistreatment of the children. Eventually, both children returned to live with Gobi. As a result of the conflict, there has been no form of family relationship between Gobi and her ex-husband and his wife. During my fieldwork, I met Headley only once, though I met his parents Rita and Dennis and his siblings Mark and Patsy, during the visits I made to Rita and Dennis' home. I never met Headley's wife Esther, and Rita told me that there were a number of reasons for that. First of all, Esther and Headley (who have no children together) live in the countryside outside of London where she spends most of her time raising animals. More importantly, while Laura and Rupert lived with Headley and Esther, Esther's mistreatment of them caused a rift in family relationships. Rita and Dennis, whose only grandchildren were Laura and Rupert at the time, became caught up in the conflict with Esther. As a result, there has never been a close relationship between Esther and Headley's family of origin.

When Laura returned to live with Gobi at aged eight, Esther forbade her to come back to her father's house. Consequently, as a young adult, neither she nor her children have been to her father's house. Contact with her father is limited to once per year at Christmas time when they come together at Rita and Dennis' home. This is also the only time Headley sees his grandchildren Lucy and Marcia. Laura has not seen her stepmother since she left her father's home, and Esther has never met Laura's children.

Headley's siblings Mark and Patsy never had children. Hence, Headley and Gobi's children remain Rita and Dennis' only blood grandchildren. Rita and Dennis have very active relationships with Gobi and all her children. Now that they are elderly and less mobile, their family comes to see them. Although Gobi and all her children – 'whatever their colour' – are usually welcome at Rita and Dennis' home, of the adult children, it is Gobi's daughter Laura who most often visit her grandparents (on a weekly basis), bringing her two children and sometimes her two younger sisters Julia and Trudy to see their 'Nanny' and 'Grandpa'. According to Laura, 'We are the only grandchildren they've got, and my children are their only great-grandchildren. They have always been there for me and my brother, and it is important to me that my children know their Nanny and Grandpa'.

Family relationships between Gobi and Headley's parents were never based on the exchange of practical help and support. For example, Rita and Dennis were never asked to provide any kind of care for their grandchildren, nor had Gobi gone to them seeking financial assistance. Their relationships were more of an emotional kind. For example, Rita and Dennis provided emotional support to Gobi after her divorce from Headley. Now in their senior years, it appears that Gobi's children bring

emotional comfort to their grandparents. According to Rita, 'they keep us going, the little ones'.

*Relationships with partner Randall and his family of origin*

Recall that Randall is the father of Gobi's two 'inherited' children Christa and Randy, and her daughter Julia. The couple had a fifteen-year relationship, then they parted and the children all remained with Gobi. At the time of my fieldwork, they had parted as a couple for eleven years. However, they maintained a close non-intimate relationship, which involves mutual emotional and practical support. Randall continued to provide care and support to the children. Due to his alcohol dependency, he occasionally loses his job and becomes homeless. Although his parents have been willing to provide him with accommodation during those times, according to him, 'I prefer to be with my children, because at least I can make myself useful by doing things for them. Being around them also gives me the courage and a reason to stay off the bottle'. Therefore, Gobi would invite him to live with her and the children. Whenever he was living in her home, he conducted himself in a manner that was familiar to the household. For example, he helped with household chores and his presence around the house made it appear, according to Gobi's son Rupert, 'like he never left'. The summer of my fieldwork was one such period when Randall had been staying with the family for three months, due to an alcohol-related accident that left him physically hurt. During this time, I observed the dynamics in the home between Randall, Gobi and the children.

I had promised Gobi's last two daughters Julia and Trudy that I would take them on a day's outing. The day would entail going to the Science Museum in the morning, returning to my house for lunch and then to a movie matinee in the early evening. I aimed to arrive at their house before Gobi left for work at 8.45, but only made it at 9.00. I rang the doorbell and Randall opened with a kitchen towel in one hand. He told me that Gobi had left, and that the girls were having their breakfast. I went into the kitchen where he offered me a cup of coffee. We sat at the table with the girls who were eager to talk about the day's events. After we were all finished, I offered to help clean up the dishes while the girls finished getting ready, but Randall declined my offer and said, 'I'll take care of that later. You just go and wait for the girls out there [pointing to the living room], they shouldn't be long'. When I entered the living room, there was a very large pile of laundry, which had been washed and was waiting to be folded. I hadn't sat down two minutes, when Randall came in, turned the television on, sat down in front of the basket of laundry and began to fold the clothes. I made a comment about the amount of laundry, and he replied, 'There are five of us

in this house at the moment'. About twenty minutes later the girls came running down the stairs, and we took off for the day.

After an exciting, exhausting and expensive day out, I took the girls home. We arrived around 8.00 in the evening and, when the door opened, like a magnet, the smell of cooking pulled the girls straight into the kitchen. By now, Gobi had come home from work, and Randall had prepared a Caribbean dish of fried dumplings, fried plantains and fried fish. I was invited to join the family for supper and, while we ate, the girls recounted the day's events to their parents. Soon afterwards, they departed upstairs for bed. Randall remained in the kitchen and cleaned up all the dishes, and Gobi and I went into the living room where she soon said to me, 'Now you've seen for yourself what I have been telling you. When he is here, he is like a part of the furniture, like he never left. And later tonight, when we all go to bed, he will just crash here on the sofa'. When Julia and Trudy were ready to go to sleep, they both came downstairs kissed Gobi, Randall and me goodnight. Around 10.30, I left to go home.

*'She was more the keeper of the family'*

Because Randall's mother Angela died in 2000, I never had the opportunity to meet her during my fieldwork. However, she was still very much alive in the family discourses. From the stories people told, it appears that she was 'the kind of grandmother who expected her children and grandchildren to come to her'. According to Randall, his mother's philosophy was, 'My family comes here [to *her* house]!' All six of Gobi's children remembered Angela as 'a very strict granny, *very strict* [her emphasis]!', who would scold them all equally if they misbehaved. Unlike the freedom of space they had in Gobi's home, at Granny Angela's house, they were only allowed to play in the television room. The main sitting area where all her ceramic figurines and crocheted doilies were on display, were, according to Christa, 'just for show'. Despite these restrictions, they spoke fondly of their regular Sunday visits to Angela, and the big pots of rice and peas she had cooking on the stove. Julia recalled how everyone would sit at the table to eat, and all the adults would be telling stories about 'back home':

We would all be at the table, my granny, my grandpa, my uncle, and my mum and my dad and us. Granny and Grandpa and my dad and my uncle would be the main people talking. They always told the same stories about the people and the places from 'back home', and when one of us [children] would ask about these people back home, they would be talking in their patois and laughing so loudly that they wouldn't even hear us. So we

were quiet at the dinner table most of the time. Also, most of the time, we couldn't talk at the table because Granny was so strict, she would say: 'Children shouldn't speak at the table!'

The children also recalled spending some of their summer holidays with their granny, and going with her to her Baptist church on Sundays. Trudy remembered being 'very bored, because we couldn't talk. And we got so hungry by the end, yet when church was over and we were ready to leave, granny would take a long time to introduce us to all the people in her church'. One of the fondest memories the children had of Granny Angela was that at Christmas she gave all six children the same amount of money to buy their presents. Apparently, Angela felt that buying things for people was a 'waste of time and money'. Instead, by giving money as gift, they could buy exactly what they like. Gobi also recalled how 'reliable' Angela was when she needed any form of help with the children.

It appears that family contact on this scale ended after Angela died in 2000. According to Gobi, 'she was more the keeper of the family'. Since Angela's death, her youngest daughter Phyllis has divorced from her husband and moved back into her parents' house, partly she said, to provide emotional support for her father. The house as I saw it had been converted into two separate dwellings, with Randall's father Richard living on the ground floor and his sister Phyllis on the second floor. Once I visited Richard with Gobi and her two youngest children Julie and Trudy, and twice I visited with the three of them along with Gobi's 'inherited' daughter Christa. Each time I visited, we sat at the kitchen table and had tea and biscuits. Conversations were usually limited to Richard asking why the children hadn't phoned him or come to see him in the week before, with Gobi responding, 'You can pick up the phone and call, too, you know!' The children appeared bored and somewhat ill at ease, especially the two youngest ones. After my first visit to Richard's house I asked Gobi: 'Why don't you and the children visit him as much as you did when Angela was alive?' She told me that since Angela died, Richard has 'slumped' into a mild depression and has essentially isolated himself. He does not leave the house to go anywhere, she explained. Furthermore, the children have grown uncomfortable around him, because they have to remain quiet in his presence, and even having the television on 'irritates' him. Hence, they have limited their visits to every other week, with regular phone calls to 'see how he is keeping'.

Recall that Randall's parents Angela and Richard had left four children behind when they migrated to Britain from the Caribbean, and only Randall and his brother Phil later followed. His sisters Joyce and Eva were left behind, and his parents had another daughter Phyllis after

they arrived in Britain (see Figure 4.4). Of the two sisters left behind, Joyce remained in the Caribbean and Eva migrated to Canada. Of Angela and Richard's children, only Randall and his brother Phil have children. I was present several times when Randall's sister Eva called from Canada to speak with Gobi and the children, and I was told many stories about the very active transnational family relationships between these family members; the regular exchange of emails, letters and phone calls. I was also shown many items of clothing and toys sent to Gobi's last two daughters by their Aunt Eva in Canada. The other children also recounted stories of presents they received from Eva. I saw many photographs, both on the kitchen wall and in photo albums of trips to the Caribbean to visit Joyce. From the stories and evidence from photographs, it appears that Gobi and the children have maintained closer relationships with Randall's siblings abroad than they have with his sister Phyllis and brother Phil who live in London. Things changed even more after his mother Angela died. As we saw earlier, before she died, the family came together weekly for 'Sunday rice and peas dinner'. The explanation for the reduced contact by Randall's sister Phyllis and his brother Phil is, according to Gobi, that 'they are professional people with very busy lives'.

The difference in the degree of contact and family relationships between Randall's siblings abroad and those in Britain might, as Randall implied, be related to time constraints on the part of his 'professional' siblings in Britain. Another possibility could be that among the children of Caribbean migrants in Britain, there might be a decline in the creole kinship traditions that their parents brought with them to Britain. However, such kinship practices and networks are still significantly maintained transnationally among migrant relatives, despite being scattered between the continents (see Bauer & Thompson 2006; Goulbourne & Chamberlain 2001, 2006; Levitt 2001; Horst & Miller 2005; Miller & Slater 2000; Olwig 1993, 2007; Byron & Condon 2008; Thomas-Hope 1998). Thus, although the effort that Angela put into maintaining family relationships might have declined among her British-born children, they continue among her Jamaican-born children who live in North America, and who are themselves first-generation migrants there. Equally significant, Gobi, who has no contact with her own sister abroad, is actively involved in a transnational relationship with Randall's siblings – for her case a form of creolisation.

#### *Relationships with partner Courtney and his family*

Courtney and Gobi lived together for one year, and he is the father of Gobi's last child, Trudy. The couple separated when Gobi was pregnant, though resumed their relationship very briefly when Trudy was two

years old. According to Gobi, this has been the pattern of their relationship since the mid-1990s. At the time of my fieldwork, they lived in separate homes. I met Courtney on a few occasions at Gobi's home. On a couple of weekends I arrived at Gobi's house to find that Trudy was away with her father and his other children (Courtney has nine children altogether with various women and, over the years, the children have all come to know each other). Besides Trudy, I only met three of Courtney's other children. The interaction I observed between the children was one of fondness and familiarity. Not only have his children come to know each other and form sibling bonds (calling each other 'sisters' and 'brothers'), but Gobi has also developed very close relationships and two of the children's mothers, Evelyn and Barbara. When I met Evelyn and Barbara, I was struck by the rapport among the three women. Although no practical help as such is exchanged between them, they regularly co-ordinate get-togethers with the children between their different homes. From the mothers' accounts, it appears that Courtney maintains good relationships with all his children, and relates to all the mothers in a similar manner.

Relationships between Gobi and Courtney's family of origin are also very strong, but the strength varies among different family members. I met Courtney's parents Betty and Daniel, his younger brother Mathew, one of his sisters, Sue, and four of Sue's five children (see Figure 4.5). His parents have been divorced for many years, and they live separately. However, whenever I visited his mother's house, his father was always present. Puzzled by the apparent closeness I observed between them (for example, the gentle manner in which they spoke to each other and the care Betty took in grooming Daniel), I asked Courtney about his parents' relationship, and he told me that 'they still see [implying intimate relationship] each other'. Additionally, Daniel had been ill, so Betty was caring for him. It appears as though Daniel and Betty are also the kind of parents who expected their children to 'come' to them. Thus, it was either Gobi or Courtney who took the children to see their grandparents. Visits and phone calls to these grandparents are not as regular as the other two sets of grandparents. However the children also call them 'Granny' and 'Grandpa' and, according to Gobi, Betty is 'always ready and willing to give help whenever you need help. I could phone her up now and say, "I'm going away for ten weeks, you've gotta have Trudy", and she would have her'.

Gobi and her children have more frequent contact with Courtney's younger brother Mathew and his sister Sue than with his other siblings. Recall that Mathew was the brother who attended the birth of Trudy and helped Gobi during the first few postpartum weeks, and he has remained close to her and her children ever since. Gobi's last two children spent their earlier years socialising with Courtney's sister Sue's

children of similar age. However, now that the children are older and the mothers are working, time together is limited, so get-togethers are less frequent.

*Gobi's relationship with her grown children*

Now that four of Gobi's children are young adults and have their own lives (for some, their own families), what forms of relatedness do they have with their mother? Gobi expressed her struggles and her concerns to me regarding the kind of parental model she has followed, and her hope for their future in their own relationships and family lives.

Sometimes I'd like to jump off, but I can't. It's OK, it's rewarding, considering the partners I've had. It's easier without a partner. There is more time for the children. But it is a struggle. It's a struggle working full-time. You try to be everything. There are times where I've worried about what they figured about men, because I tend to fix cars, do household things, and they've not got any good role models. I hope they are able to build good relationships at some stage, 'cause it would be very sad if they ended in the same way that I did [laughs]...

I live an extremely hectic life, but I'm not that materialistic, compared to the rest of my family [of origin]. And I suppose the work I do [social work] is all-consuming. You are always looking after other people's needs, and sometimes neglecting your own family's needs...

Despite the life I've had, I think my children have a pretty good experience really. I think they've got the best of both worlds, although they, too, have their own struggles. I think it could be quite hard for them sometimes, because society makes them feel like they don't belong to either world. But I hope they can get past the stereotyping, not just in society but also within families, because my own sister became anti where I was and cut me off. Maybe as more and more people become mixed-race, with more and more people of all different races mixing up, and we all look more alike with bigger ears or smaller ears, then we'll start picking on something else. For now anyway, my family certainly enjoy the diversity. The food... they certainly get out and about. They are constantly meeting people from all different cultures.

Here Gobi makes some very interesting points on gender and kinship. Let me first address her comment on life without a partner: 'It is easier without a partner. There is more time for the children'. From this, it might appear that she no longer feels the need for a partner and male



figure in her children's lives. In her work entitled *Gender, Family and Work in Naples*, Goddard (1996: 201) concluded that 'women's identities are enmeshed in ideals of the family and in their sense of fulfillment in family life...[and] having a child was generally considered to be the most important event in a woman's life'. However, as gleaned from my many conversations with Gobi, her feelings do not entirely correspond with this view. Although her investment in her children is a primary objective in her life, she also wishes that she had a 'consistent' partner and a 'stable' male figure for her children. Moreover, she does not find life without a man entirely fulfilling, and misses the intimacy that comes from having a stable partner.

Gobi's situation corresponds more closely with the phenomenon described as 'matrifocality' among many Caribbean families (see Smith 1988; Barrow 1996). Matrifocality is an 'adaptive mechanism' whereby women in particular, devise certain survival strategies 'to cope with inadequate and uncertain male support in circumstances of poverty, unemployment and male migration' (Barrow 1996: 73). In Gobi's case, her matrifocal position arises from a combination of divorce and inconsistent male support from the fathers of her children. For although ex-partner Randall sometimes offers help and support around the house, his alcoholism renders him unreliable. Hence, her circumstances left her with little choice but to, in her own words, 'be everything' to her children.

Another noteworthy point in Gobi's account is that she does not express herself in terms of her own hardship or, as Goddard found among women in her Naples study, in terms of 'sacrifice' (Goddard 1996: 183-203), although she is clearly investing a lot of time and effort in others at home and at work (as a social worker). Instead, her expressions convey ideas about good mothering while, at the same time, her investment in the extensive family links may be seen as compensating for the isolation she and her children might have suffered from not having a steady father figure, and lack of support from her family of origin.

Despite Gobi's concerns, her children all appear to have close relationships with her. While she does indeed have a very busy work schedule, with little time to visit her grown children, her house is the hub of the family activities. Most times I visited her home, one of her elder children was either present, calling on the phone or spontaneously dropping in. Gobi's daughter Christa works with her as a social worker, so they are in daily contact. Christa is caring for her younger sister Gabriella while their birth mother Mona is unfit to do so, so she also has a very busy life. However, there were many a time when I was at Gobi's home and Christa and young Gabriella dropped by. Strikingly, Gabriella also calls Gobi 'Mum'.

Gobi's birth daughter Laura also visits occasionally during the week with her two children and regularly on Sundays. In the past when Gobi's youngest children were smaller and Laura was home more with her own children, she would sometimes help mind her younger sisters when necessary. However, now that she works full-time and the younger children are in school, visits to Gobi's apart from Sundays need to be arranged, due to time constraints.

Gobi's son Randy, a carpenter, does have a partner, and he makes frequent visits and phone calls to her home. Her son Rupert works full-time as an electrician, and lives with his partner in Gobi's home. According to Gobi, 'he has become the main male role model for the kids'. He is the person who does the more physical activities around the house, such as laying floors, painting walls and fixing plumbing and light fixtures. Rupert will not do laundry, but whenever Gobi works late, he will either cook or take his younger siblings out to supper. He also helps out by taking his younger sisters to their afterschool activities.

Rupert appears fulfilled by his role as the male head of the household, despite Gobi's anxiety about the lack of positive male role model in the family. When he walks through the door from work, he announces his arrival – often bearing little treats for his younger sisters – and almost demandingly requires acknowledgment. For example, on one of my visits, I stayed until late into the night talking with Gobi, long after the two younger children had gone to bed. Rupert arrived home at 10.00 and rushed through the front door yelling, 'I'm home! Where is everyone?' After saying hello to Gobi and me, he went upstairs to the girls' room and woke them up to ask about their day. When I asked him afterwards why he woke the girls up, he replied, 'I just like to know how they get on during the days'. His behaviour implied a sense of responsibility and fulfilment as the primary male in the house.

I have kept in regular contact with some of the families in my research even after I completed fieldwork, and Gobi's is one such family. About five months after I completed my fieldwork, I was in her neighbourhood and decided to pay her a visit. When I arrived at the house, her daughter Christa and Christa's sister Gabriella were also there. I asked for Gobi, and Christa told me that she was away, so that she herself was minding her two younger sisters. Gobi's absence was due to her children Christa and Rupert's treating her to a week-long holiday in India, in celebration of her 50th birthday. In the meantime, Christa had moved into the house with Gabriella, the sister she is raising, so she could assist Rupert in minding their younger sisters Julia and Trudy while Gobi was away.

Although Gobi's older children would help out in terms of minding their younger siblings and doing house chores, and they gave their

mother a grand holiday for her birthday, Gobi did not express the need for, or requirement of, any form of reciprocity from her children. She even paid her daughter Laura for childcare when her younger children were small and she had to go to work. Thus, one is inclined to analyse her behaviour in terms of negative reciprocity (see Mauss 1966; Horst & Miller 2005). However, I believe that the effort that she puts into doing kinship implies a latent form of reciprocity. Although she told me that she sometimes gets 'exhausted' by all the activities and responsibilities of her large extended family, she has also said that the effort she makes 'for the children to keep in touch with each other' is worth the 'joys it brings to my family as a whole'. Thus, from her efforts, she gains satisfaction from creating a wide and active kin network for her children and for herself.

Indeed, I have seen some of the effort she has put into bringing her children together. For example, I arrived on some Sundays to find her cooking – for what seemed like the whole afternoon – huge pots of food for what she termed 'open-door Sunday for whoever turns up'. And although I never experienced anything like the 'sit-down Sunday dinner' they described at her ex-partner Randall's parents' home when his mother Angela was still alive, I did observe all the children coming in at various times throughout the day and helping themselves to the food Gobi had prepared.

This very laid-back and flexible approach to Sunday dinners is a modification in Gobi's current family. As a child, her family had formal commensal Sunday lunches with just the nuclear family. In Angela's house, Sunday dinners after church included the extended family and, although her house was not very large, the occasion was formal. The family ate together at her grand dining table that occupied the length of the dining-room. While the older relatives reminisced, the younger children sat quietly and 'behaved'. Gobi's house is much smaller, a three-bedroom council house with a combined kitchen-diner. Hence, rather than arriving after church and eating together, her children's different lifestyles now mean that they arrive at different times. Thus, Sunday dinner now has an open-door, individualistic approach, bringing modifications to family practice in order to accommodate both shifts in house space and in family members' lifestyles.

The type of food itself has also been modified to suit the different palates in Gobi's current family. Unlike the 'English' food that she grew up eating and the 'Caribbean' food that Angela prepared, food in Gobi's house is a mixture of English, Caribbean, Indian and Italian cuisines, which she has learned to cook from different family members and friends – another creole adaptation.

### *Sibling relationships*

During the course of my fieldwork, I had various insights into sibling relationships not only between Gobi's children, but also between her children and their siblings' siblings and between Gobi and the siblings of her ex-partners. As we have seen throughout this chapter, Gobi's relationship with her only sibling, her sister Misty, ended when she divorced her first husband Headley and came together with her second partner Randall. Their relationship was never repaired. On the other hand, over the years, Gobi had developed various forms of relationship with her partners' siblings. The relationships she developed with her first husband Headley's siblings were weakened after her divorce. She still maintains contact, but only to a minimal degree, and there is no form of help or support exchanged between them. She has maintained very close relationships with two of her second partner Randall's siblings, a sister in the Caribbean and another sister in Canada. These are the sisters with whom she regularly communicates and who send regular presents and financial help to her and her children. She also has close relationships with two of her ex-partner Courtney's siblings. One is his brother Mathew, who assisted her during Trudy's birth, and the other is his sister Sue. Mathew has continued to be an active 'family friend' who, according to Gobi, 'is like the brother I never had'. He brings gifts not only for the children, but also for Gobi, and offers help when she needs it. Gobi and Sue spent more time together and exchanged help when their children were smaller because they worked part-time then. Now that the children have grown up, they have taken full-time jobs and, along with the continued demands of family lives, they are physically together less. However, they continue to speak regularly on the telephone and they periodically take their children together on camping trips. There isn't a lot of practical help exchanged between these women, but there is an understanding that mutual support may be activated when necessary.

Sibling relationships between Gobi's children vary in form and intensity, reflecting variations in their shared experiences and shared parental bonds. To begin with, there is the special relationship and bond between Gobi's birth children and her 'inherited' children. There is also the relationship between her 'inherited' children and *their* siblings by their birth mother. There is also the relationship between Gobi's last two children and *their* siblings by their father. I shall try to convey these sibling relationships through little vignettes of the different situations I observed on various occasions.

Beginning with Gobi's six children, recall that her first two children Laura and Rupert are from her marriage to first husband Headley; her second two children Christa and Randy are her 'inherited' children by

her second partner Randall, who is also the father of her fifth child Julia; and her last child Trudy is by her partner Courtney. The forms of relatedness I observed among these six children are strikingly close. In the absence of each other, they all refer to one another as 'sisters' and 'brothers'. There was the situation that I described earlier, of the outing that I had with Julia and Trudy. After we returned to my house, the girls drew pictures of their family while they watched television and waited for the lunch I was preparing in the kitchen. Over lunch, we discussed the drawings. Trudy's family picture had a much larger number of people than Julia's family picture and, when I asked about the difference, Trudy very enthusiastically told me that her family is larger because she has fourteen brothers and sisters. 'Fourteen brothers and sisters?' I asked surprised since, at this stage in my research, I hadn't thought of the links between siblings. I asked her to place her siblings. 'Well', she said, 'there are five from my mum, eight from my dad and my sister who lives with Christa [Gabriella who shares the same mother as Trudy's sister, Christa]'. 'But you and Gabriella neither have the same mother nor father!' I replied. 'That doesn't matter!' they both replied. 'She lives with our sister, and they are sisters, so we are all sisters, and we play together all the time. Our mum is her mum also,' Julia replied. 'How so?' I asked her. 'Because she calls my mum "Mum,"' said Julia. 'And Gabriella and I are the same age. We are both nine years old, and we wear each other's clothes, and everything,' added Trudy. Under the circumstances, I asked Julia why she didn't include Trudy's eight siblings by her father, and she replied: 'But they don't live with us, and I am not related to their mothers. So they are like my cousins. Trudy spends more time with them, and I spend time with them too, but mostly when we go camping or something'.

Although Gobi's three grown children Laura, Christa, and Randy live nearby, they lead very busy lives. Therefore, they are not around her home as often as Rupert and the two smaller children. However, I have observed times when Christa visits and Julia and Trudy leap at her in large embraces. Greetings between the older siblings were never embraces, but more slapping on the shoulders, or comments – sometimes jokingly – about their appearance. The younger children were mainly the ones around which activities were centred. The relationships between Gobi's 'inherited' children Randy and Christa and their blood sibling are also remarkable. Randy and Christa share one other sibling, nine year-old Gabriella by their mother Mona. As we might recall, Christa at present is caring for her sister Gabriella while their mother is unfit to do so.

Lastly, there is the relationship between Gobi's daughter Trudy and her eight siblings by her father. Since these siblings have all come to know each other, they often spend weekends together at their father's

home. Additionally, Gobi has maintained a close relationship with two of the mothers of the children, so that they occasionally take the children camping and other leisure activities.

## Summary and conclusions

### *'My family is who is around me'*

This chapter shows how Gobi's highly complex family is created primarily by the agency of women, and is activated through the links between the children. For, despite the separation of parents or the separation of children and their parents (as in the case of separation and divorce or, in the case of the parents going to prison), the separation of the siblings is avoided at all costs. By keeping the siblings together, relations between families are maintained. It is primarily the women in Gobi's kinship network who are the active maintainers of family relationships, and the significance of children is symbolic to the maintenance of the network. As Gobi herself put it: 'All I do is make an effort for the children to keep in touch with each other'. The phrase, 'she was more the keeper of the family' was said by Gobi about her ex-partner Randall's mother, but is a common theme that relates to the women in the family.

Beginning with the separation of Gobi and her first husband Headley, it was the efforts of Gobi and Headley's mother that kept the link between the two families. When the birth mother of her partner Randall's children was deemed unfit to care for her children, Gobi took the children so that the siblings would not be separated, but also because she felt that it was important that they remained 'connected' to their father. Gobi has also been active in the formation and maintenance of the sibling and family relationships between her last daughter Trudy and Trudy's father Courtney's family, and she also has active relationships with Courtney's other children and their mothers.

This pattern of maintaining the extended family link that has been created by the existence of children has continued transgenerationally with Gobi's daughter Christa. When Christa's little sister Gabriella was about to be placed in care by social services, because her parents were unable to care for her, Christa, in the spirit of her Caribbean father and her white English mother's creolised kinship practice, took over the care of her younger sister. By doing this, the closeness between the siblings was maintained, and the ties within the family that Gabriella had grown to know were also maintained. For Gobi's daughter Laura, family maintenance is also important. Although Laura does not have a good relationship with her father, she regularly visits her father's parents, because she believes that, 'it is important for the children to have a

relationship with their great-grandparents, and for Granny and Grandpa to know their only great-grandchildren'.

Finally, it became clear after the death of Gobi's ex-partner Randall's mother Angela that Angela had been the 'keeper' of his branch of the family. While she was alive, family relationships were active and contacts were frequent. After she died, these were minimised and the children no longer related in the same manner with their grandfather, as when their grandmother was alive.

Gobi's informal keeping of Randall's children after they parted (because their birth mother was unable to care for them), is a form of creole child fostering (sometimes called child-shifting) that is common among Caribbean families. In Chapter 3, we saw Dusty and Dawn Smith also informally fostering their granddaughter Nancy. In Gobi's case, the practice is 'inherited' by a white non-biological family member. Gobi has strategically managed to keep the children without the formal involvement of the law and, instead, informally, with support from the child's extended family network. Furthermore, this creole child fostering that began with Gobi has continued transgenerationally with her daughter Christa, who now takes care of her younger sister, because their birth mother is unable to provide care for her.

Another feature of the creole family that operates in Gobi's family is the role men play in linking the chain of kinship, 'contradicting the idea that unstable conjugal unions expunge males from kinship networks' (Smith 1988: 79; see also Black 1995). In his work on West Indian kinship, R. T. Smith (1988) found that when an unmarried couple has a child, the child's father's kin become incorporated into the kin network of the mother and child. Moreover, even after the relationship ends between the parents, the relationship between the child's mother and the relatives of the child's father (particularly the baby father's mother) continue (ibid.: 45). Thus, as with the creole families, we find that, although Gobi separated from her three partners, she maintains strong relationships with their relatives. Moreover, she goes a step further to build relationships with the mothers of her ex-partners' other children.

The links that are formed among the children are also remarkable. These links occur not only through blood relations, but also through non-blood relations. The links created through blood relations are interwoven from the different and complex parental strands, thus creating an uneven number of siblings for each child. Of Gobi's six children, four are her birth children and two are her 'inherited' children from the same birth mother and father. The first two of her children by her first husband share the same biological father, her two 'inherited' children and her third birth child have the same biological father and her last child (her fourth birth child) has a different father from her other

five children. Concurrently, interwoven into these sibling sets are further sibling linkages, extending sibling relationships beyond the nucleus of Gobi's home. Thus, four of her children have siblings both inside the nucleus of their family and beyond it. While her 'inherited' children Christa and Randy share the same father as Gobi's birth daughter Julia, they also have two sisters with whom they share the same birth mother and with whom they have very close and active relationships. Additionally, Gobi's youngest child Trudy has eight other siblings with whom she only shares her biological father and with whom she also has active relationships. Thus, of Gobi's children, Trudy has the largest number of siblings to whom she is related by blood (eleven) but, for all the children, there are also as many possible non-blood linkages with step-siblings.

It is this crossing of biological and non-biological siblingship that forms the essence of Gobi's kinship network. Family relations cannot be traced exclusively – or even easily – through genealogical relations of filiation (relations resulting from parental line of descent) or alliance (relations between families through marriage). Instead, relations are more easily traced through the ties or connections between children, grandchildren and siblings. Additionally, as with the creole family the use of kin terms is based on personal experience rather than on descent.

Gobi's family demonstrates what Carsten (1997) observes from her study of kinship in a Malay fishing community, that, 'siblingship above all connotes unity and similarity' (ibid.: 25). Although the range of siblings in Gobi's family is not brought up inclusively in one house as with the families in Carsten's research (ibid.: Chapter 3), they, too, have incorporated difference into similarity. Coming from different parental strands, they incorporate difference into similarity by the links created between siblings as well as by those created through their connections between their various parents, grandparents and other relatives. As we have seen throughout the chapter, forms of relatedness are similar between Gobi's children and their three sets of grandparents, whether they are blood-related or not. The children all call their grandparents 'Grandma' or 'Granny' and 'Grandpa'. To the children, Gobi is 'Mum' and, to each other, they are 'sisters' and 'brothers'. Moreover, as with Carsten's Malay families, sharing space and daily life is a crucial aspect of the siblings in Gobi's family. This is evident in their interactions and the degree of intensity and frequency of interactions over and above genealogical ties (see also Edwards et al. 2006 for sibling relationships).

As with Carsten's (1995, 1997, 2004) Malay families, the house in Gobi's family plays a crucial role in the making of kinship. While some of the features of Carsten's Langkawi house do not apply to Gobi's family, her suggestion that houses in Langkawi are strongly associated



with women and children accords with Gobi's family. For Gobi, houses, feeding, women and sibling sets are all intimately bound up with each other and with the way kinship is lived and conceptualised. Originally, it was the house of Gobi's Caribbean mother-in-law Angela that provided a context where family members came together regularly to share food, family stories and family issues. After Angela's death, although Gobi's house is smaller, it became the context for practising family traditions, albeit, traditions that have been transformed to adjust for space and individual lifestyles. For example, Gobi has continued the tradition of Sunday dinners but, unlike the formal approach to commensality that she grew up with and that Angela practised, Gobi adapted a creole approach to Sunday dinner, replacing the formal aspect to a more individualistic approach. Gobi's house also provides a context for continuity for relationships not only with her ex-partners, but also with their additional (or 'outside') children and the children's mothers.

Although Gobi has a large extended kinship network, members in the network do not relate to each other with the same degree of closeness, contact or support. How do we interpret these distinctions? The difference in the forms of relatedness in this kin network is akin to the difference that Bourdieu (1977, 1990) describes between 'official kinship' and 'practical kinship'. Bourdieu argues that kin relationships have different 'functions' or 'uses' for different members within the 'group'. Hence, there is 'official kinship' that is based primarily on genealogical ties and ties through marriage; the uses of kinship among the group are reserved for 'official situations in which they serve the function of ordering the social world and legitimating that order' (Bourdieu 1977: 34). In other words, official kinship functions as a form of 'representational kinship' that serves as self-representation among the group (ibid.: 35). 'Practical kinship', by contrast, is a kinship network that includes

not only the set of those genealogical relationships that are kept in working order (which I shall call practical kinship) but also all the non-genealogical relationships that can be mobilized for the ordinary needs of existence (that is, practical relationships). (Bourdieu 1990: 168)

Among Gobi's family of origin, her sister Misty and her Aunt Vicky could be described as 'official' or 'representational kin', since relationships with them do not serve any practical function. Gobi refers to them as 'only family in name, and not the kind of family who do things for you'. Due to factors such as class and colour, social divisions have kept Gobi and her aunt and sister apart. This is evident in the manner by which Gobi's sister Misty ended their relationship when Gobi

became involved with her Caribbean partner Randall, and the fact that her Aunt Vicky will only invite Gobi's birth children to her family occasions, but not her two 'black' children. Thus, Aunt Vicky's behaviour suggests that genealogy matters over non-blood, but this formal view has been reinforced by colour prejudice.

For Gobi and other members in her kinship network, forms of relatedness are not contingent upon blood ties, class, colour or geographical proximity, but are based upon the history of their relationships, their shared experiences and the practical and emotional support among family members. These may be activated or mobilised by the group members through their connections whenever necessary. However, there are different degrees of relatedness among the different strands of her kin network. Thus, Gobi relates more closely to the family of her ex-partner Randall, partly because they have a longer history together, but also perhaps, most importantly, because they have worked the hardest and most consistently between them to maintain family connectedness. However, in the final analysis, family and kinship are to Gobi, 'who is around me', and with whom she feels most comfortable and shares in mutual support. The large display of family photos on her kitchen walls is evidence of her view. Gobi's concept of 'my family is who is around me' seems to apply also to her children's perception of family. The case of Trudy and Julia on our day's outing is a case in point. The pictures of the family that the girls drew included only those members of their family whom they saw regularly and with whom they have regular contacts.

In sum, due to the lack of emphasis on the importance of children and siblingship in British kinship studies, it is difficult to compare the situation that exists within Gobi's, and many of the families in my London research. The significance of children and siblings as the main links connecting the kinship network in this study has some resonance with Carsten's (1997) work on Malay kinship, but the complexities within these links make them very much more akin to the situation found in many Caribbean families.

**Key to Figures 4.1 - 4.6**

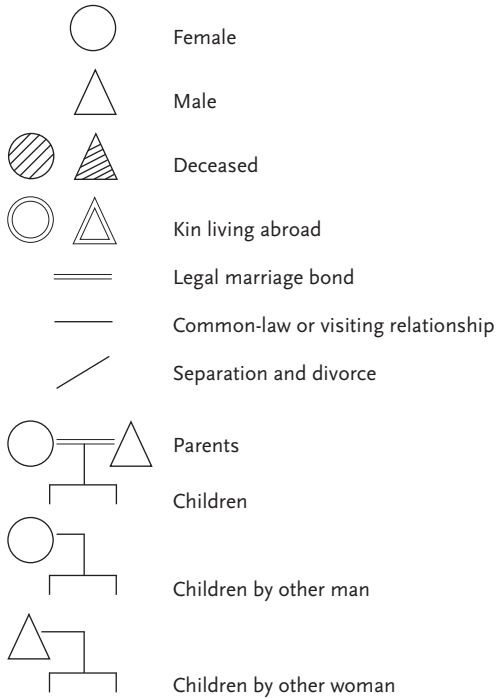

**Figure 4.1** *Gobi's family of origin*



**Figure 4.2** *Headley's family of origin*

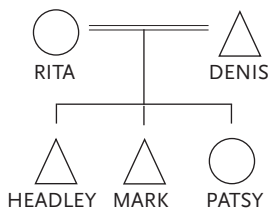

**Figure 4.3** *Gobi and Headley's extended family*

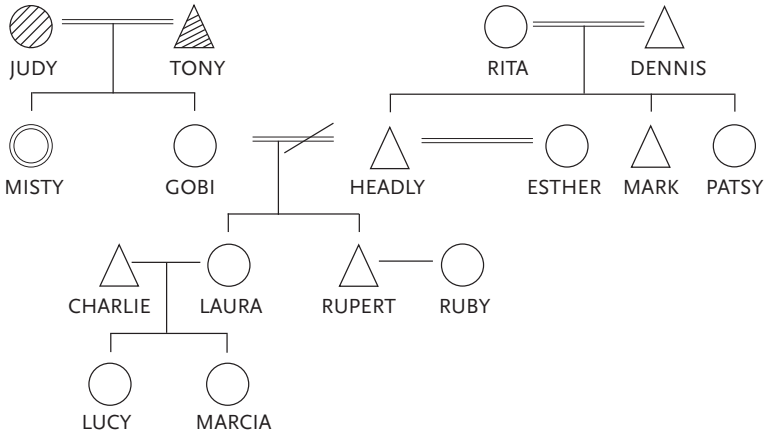

**Figure 4.4** *Randall's family*

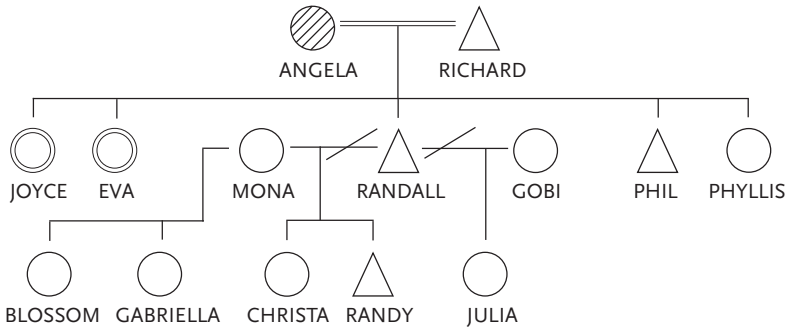

**Figure 4.5** *Courtney's family*

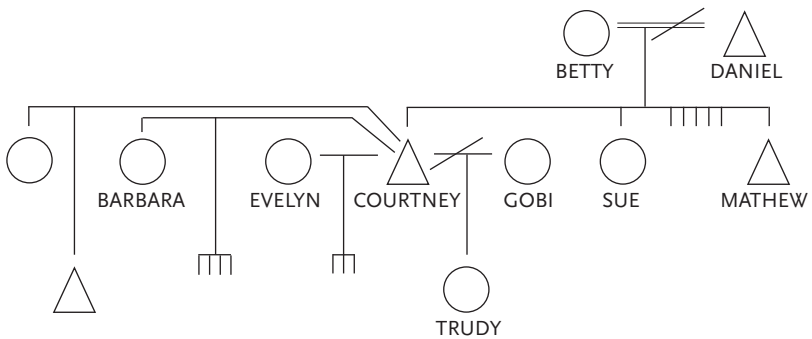
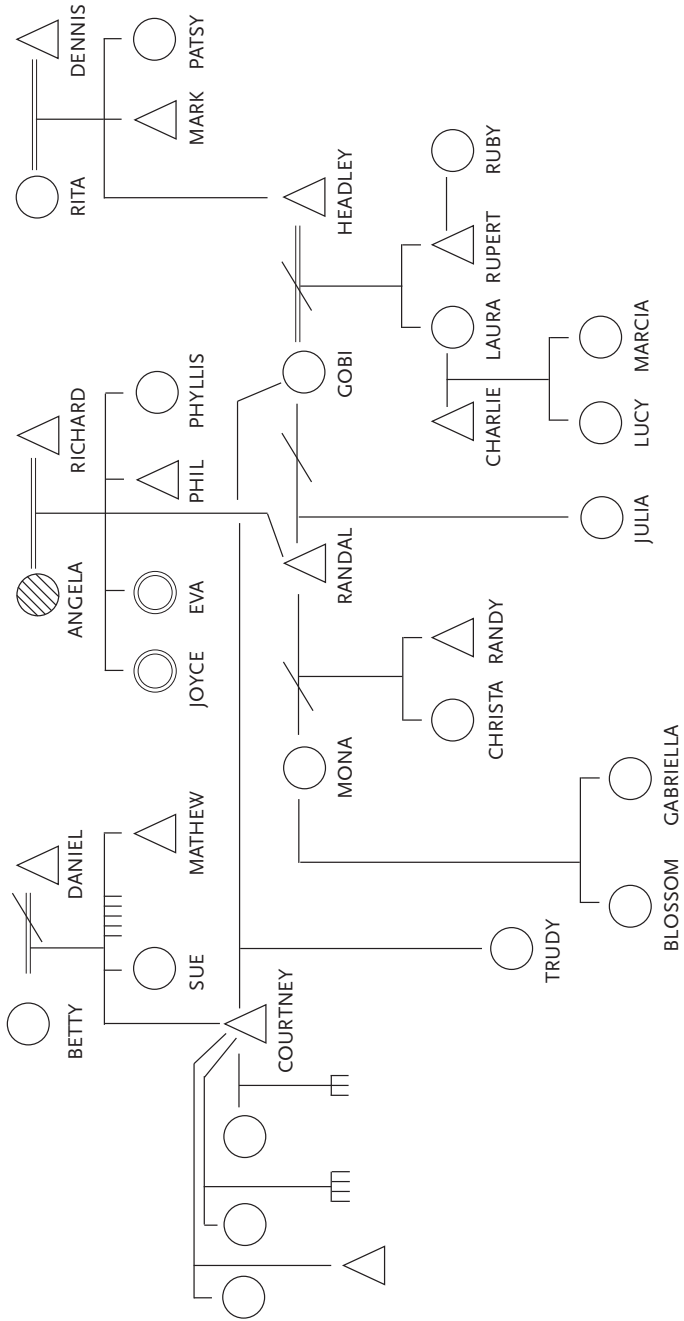

Figure 4.6 Gobi's extended family





## **5 Kinship histories: The significance of family history in the creation and maintenance of kinship relations**

In the preceding chapter I described how – like many families in my research set – the children in Gobi’s family are crucial to the creation and maintenance of kinship relations. I also showed how the women in Gobi’s family are the primary actors in maintaining relationships among the extended family, and they do this partly for the purpose of ‘keeping the children together’. Through another family, this chapter explores further the central role of women in making kinship, albeit in different ways. Central to this chapter is the endurance of kinship relationships over time and space and during crises, and how obtaining life stories and kinship histories can be as essential as contemporary observation in reaching an understanding of these patterns. This chapter will again focus on one family, the extended family of Verna Morgan and her husband Ken Morgan.

Very early on in the research, Verna and Ken promised to invite me to their next extended family gathering, for, as Ken described it, ‘a taste of our family’. Two months after meeting the couple and their children (along with Verna’s siblings Jude and Kate and Kate’s daughter Ashley), Verna called one evening to invite me to a family dinner at a restaurant in central London. She gave me no detail other than the place, date and time of the dinner. It was a grey November afternoon and being unfamiliar with that part of London, I gave myself ample time to get to the restaurant. Upon arrival, I recognised Verna and Ken sitting at a large table with various other people, some of whom I had previously met at the couple’s home – such as their children and Verna’s siblings – and others whom I had never met before. I walked up to the table and was introduced to all by Verna, who also introduced everyone to me: ‘This is Eve, Ken’s mum, his father Tylor, his sister Maggie, his brother Junior and his wife Dolly and their son Malek, his brother Lucas and his partner Lola, and my brother Jude and sister Kate, and the children you’ve met before. My father and Page should be arriving soon’. Verna offered me a chair next to her and, though I was bursting with curiosity to find out what the occasion was about, I restrained myself from asking. However, Verna, who must have perceived my curiosity, explained to me that the occasion was a double birthday celebration of Ken’s sister Maggie, who had turned 40, and of Verna’s brother Jude, who had turned 22.

It wasn't five minutes after I sat down, that there was a sudden hush followed by 'gosh', as everyone at the table looked towards the door of the restaurant. My eyes followed their gazes to the two figures that walked towards our table, one of whom was indeed an image to behold. It was that of a very tall, dark and impressive-looking man with dreadlocks draped down his shoulders, ending just above his waistline. Atop his locks, he wore a dark brown leather hat, similar to a baseball cap but with much more material, creating a fuller puffed look around the sides, with a band that cinched it all around his head. He also wore a brown leather bag slung diagonally across his shoulder and, as my eyes followed his attire downwards, I was struck by his open-toed, epic-style sandals. As he walked towards our table, Verna stood up and embraced him. She then turned to us and said, 'You all know my dad and Page'. To me she said, 'Elaine, this is my father Lionel and his partner Page'. I acknowledged the introduction and introduced myself. As the celebrations continued, and it was clear that there would be no other late arrivals, I began to think about some of Ken and Verna's other relatives whom I had heard about, and wondered why they were not present. However, since I felt that this was not the occasion to be inquiring about the missing relatives, I spent the evening observing the personalities of the individuals around the table – and the relationship dynamics between them.

Verna's father Lionel stood out not only for his very commanding presence, but also because he was a man with a big personality who related to the majority of those around the table with great ease. Ken's mother Eve (who had been divorced from Tylor for many years) also demonstrated a great vivacity, and related to everyone with apparent ease. His father Tylor, on the contrary, appeared uneasy and, after the final course was eaten, kept looking at his watch, until eventually Eve turned to him and said, 'You know Tylor, I'm sure that the others would understand if you had to leave'. Tylor took Eve's comment as permission to leave, and said goodbye to all. After he left, the party became even more alive, as individuals began telling various family stories. The most noteworthy moments in the storytelling, however, were the stories about Verna's mother Chantal while she was alive. Chantal had died four years earlier, but her memory was still fresh in the minds of everyone and, with each of these stories, the atmosphere seemed suddenly overcome with a sense of great sadness. Finally, Eve – who, according to her, 'had such a special relationship with Chantal, we knew each other's souls' – reminded everyone that 'Chantal might have passed on in the flesh, but her true spirit and her being are still living within us. I am sure she is right here now with us, and wouldn't want this gloom hanging about!' After this, everyone drank 'to Chantal', and it felt as if the sadness had been lifted.



At the end of the evening, I left with a multitude of questions in my head, including the reasons for missing family members, the diverse relationship dynamics I observed among individuals and the significance of Chantal to the family relatedness. Among these questions, however, my overarching questions were: firstly, why was Verna's mother Chantal who was no longer physically alive, 'still living within' this family in such a significant way? I wanted to find out more about the significance of Chantal's enduring influence in the making of kinship among this family. And secondly, what had been the effects of the many break ups and new unions on kinship relationships in Ken and Verna's family? It soon became clear to me that answers to these questions were not going to be gained through participant observation alone. I would also need to explore the family histories of Ken and Verna's family through in-depth interviews.

As I argued in Chapter 2, although participant observation is a key element in fieldwork, people's oral narratives and explanations of their family histories expand our understanding of the practices we observe. Thus, oral narratives through formal and informal interviews and casual conversations were not only useful in providing background and social texture to their family relatedness in the present, but also effectively addressed the questions I was pondering when I left the family dinner. In particular, this approach brought Verna's absent mother Chantal out of obscurity through the many voices that share memories of her, and highlighted how their shared images of her have, to a large degree, informed their collective experiences in their relationships as kin.

### **Verna and Ken Morgan**

Verna was born in Wolverhampton, UK, in the late 1960s to an English mother, Chantal, and a Barbadian father, Lionel. Verna attended the local primary and secondary schools. At seventeen, she met Michael, her first husband, a black professional man and, within their first four years together, she had her first two children Damian and Patti. Shortly after Patti was born, Verna and Michael moved their family to London. Soon after arriving in London, she enrolled in university to study literature. Two years after enrolling, the couple separated, and Verna moved into her own flat with her two children. During her first year at university, she met Ken Morgan, who was enrolled in the same degree course.

Ken was born in the late 1960s in Eastbourne to English parents, Eve and Tylor. Ken attended primary and secondary schools in Sussex. When he was nineteen, his parents separated, and he went to live near his sister Maggie nearby. At 21, Ken moved to study literature in

London, and there he met Verna. Approximately seven months after meeting her, he moved into her home to live with her and her two children and, two years later, their son Jonah was born. At the time of my research, Ken and Verna had been living together as a couple for nine years.

## **Verna and Ken's kinship history**

### *Verna's family of origin*

Verna's mother Chantal died four years before this research was conducted. As such, the family history told here is based on accounts by Verna and her siblings Jude and Kate. Some of the events they recounted are stories told to them by their mother and father. There are also stories from their father Lionel and from Verna's husband Ken and his mother Eve.

Verna is the first of the three children of Chantal and Lionel Jones. Chantal was born in the mid-1940s in Wolverhampton, the last of seven children of Catholic parents Myra and Simon, who migrated from Ireland to Wolverhampton in the late 1920s (see Figure 5.2 at the end of this chapter). Simon and Myra had their first two children in Ireland before migrating to Wolverhampton. There, Simon worked as a shoemaker and Myra, as a cleaner at the university and in private homes. According to the family stories, Simon went to work during the week and, on the weekends he 'would drink his pay before he came home'. He was never home very much, sometimes disappearing for 'days on end, here and there', and the family had no idea of his whereabouts. Thus, it was essentially Myra who raised their children. Simon was remembered as 'a difficult man who was an alcoholic, and who was violent and physically abusive to his wife and children'. He died from a heart attack when Verna was seven years old, and Myra died the next year from a stroke.

Although Myra took Chantal and her siblings to church every Sunday, Chantal 'couldn't wait to give it [religion] up'. According to Verna, Chantal was very vocal about 'leaving behind her religion'. She felt 'repressed by Catholicism', which, in her view, was about 'guilt, and confession and cleansing of the soul'. Indeed, she never returned to church after she left home at age fifteen. Neither did she baptise any of her children.

Verna's father Lionel was born in Barbados in the late 1940s, the first of two children of Boysie and Evadney. In addition, Lionel has three step-siblings as his mother had three other children, each by different fathers (see Figure 5.2). Although Evadney ran her own successful hair-dressing business in Barbados, during the early 1950s when post-War

mass migration from the Caribbean to Britain was still in full swing due to Britain's labour-thirsty economy, she took the chance to migrate to Wolverhampton. This was in order 'to give her children an even better life' and the opportunity, she thought, of a better education. She left Lionel and three of his siblings, Jenny, Joyce and Milo, in the care of their extended family in Barbados. Lionel's father Boysie also migrated to Britain during the same period, but lived separately from Evadney. Soon after arriving in Britain, Evadney secured a job as a hairdresser and, within a couple of years, bought her own home and set up her own business on the ground floor of her house. She also had another child, Manzie, within the first two years of settling in Wolverhampton. By the mid-1950s when she saved up enough from her business, she sent for Lionel, Joyce, and Milo to join her. Her first child Jenny stayed on with family in Barbados, and later (in the 1960s) migrated to the US.

### **Chantal meets Lionel**

In 1960s Wolverhampton, there existed an already growing African-Caribbean community. Thus, it was not unlikely that Chantal and Lionel would come together as young adults, after they had already experienced mixed sociability in their schools and elsewhere. Furthermore, by the time Chantal met Lionel, she already had black friends and had been highly influenced by Jamaican reggae, ska and American soul music, while attending dance clubs where these kinds of music were played. It was at one such Wolverhampton nightclub in the late 1960s that she met Lionel, who was singing at the club. They developed a relationship and moved into a flat together as a couple. From Verna's account, based on what her mother told her, Chantal's father and her brothers were not pleased when she 'hooked up with a black guy, so there was a bit of conflict when they first got together'. Moreover, Lionel's lifestyle as a musician intensified the disapproval among Chantal's brothers. According to Verna's brother Jude: 'As a musician dad went off and left mum alone with us a lot. That was the problem that some of her brothers had, that he wasn't traditional, he didn't do what they did with their wives'. Indeed, all of Chantal's siblings became upwardly mobile from their poor family backgrounds. They all went to convent schools, though only Chantal went on to higher education. However, they all secured regular jobs – some owned their own businesses – got married and bought their own homes.

Despite her family's disapproval, Chantal and Lionel continued their relationship. A year later, she became pregnant and she gave birth to Verna. Although Verna was a 'planned and wanted child', immediately

after her birth, Lionel 'disappeared' and didn't return for six weeks. From Verna's account, it appeared that Lionel was always 'coming and going' throughout her childhood. She remembers how: 'my dad was never a permanent fixture in our home. One day he would be home and everything would be fine, and the next day he would be gone, and we wouldn't see him for weeks'.

Despite Lionel's unpredictable behaviour, according to what Chantal told her children, she wished to be legally married to him. As I was told, 'she would ask him regularly, and he would regularly turn her down'. However, she never gave up 'hope'. Eventually, she officially changed her surname from MacNab (her birth name) to Jones (his birth name) because, as she told Verna, she 'loved' and 'adored' Lionel and 'wanted to marry him'. Chantal's deep love notwithstanding, the feminism of the 1960s and 1970s had not obliterated assumptions about marriage and family and gender relations that churches, schools and the media continued to promulgate. Life was difficult for mothers and children from unmarried families (Benson 2005: 128). Hence, as Chantal told her children, having the same surname would give the impression that she and Lionel were a married couple, and make life much easier when dealing with doctors and school authorities. Thus, although she rejected religion and religious attitudes and tried to be innovative in her behaviour and practices, her decision was also very much influenced by traditional attitudes.

### **Life continued with the help and support of family and friends**

Not only was Lionel often absent from his new family, but he also did not provide regular support for them. In order to survive, Chantal did cleaning and child-minding jobs while also receiving income support. Although members of her family of origin were not very pleased with her choice of partner, they had come to accept it. However, after Verna was born, their feelings of disapproval resurfaced in sympathy for Chantal. As a Christian family, their views were, according to Verna, 'you got married and through hell and high water, you stick together'. Therefore, Chantal's situation was 'abominable', and they could not understand why Lionel was behaving the way he did. Yet, despite their feelings, Chantal and her siblings remained in close contact, and they offered various forms of help and support to her and baby Verna.

Help and support from Chantal's family of origin came mainly from her brothers. Due to advanced age, ill health and lack of finances, her parents were incapable of providing any practical help. Verna remembered how, as a little girl, her uncles came to her house, pleading to Chantal to leave Lionel: 'Why are you still with him? There are so many

good white men out there who could marry you. Why do you stay with this man?' Before leaving, they often gave her money to buy food and to help with the bills.

Chantal had also become closely aligned with Lionel's family network. In particular, she had developed close relationships with his mother Evadney and his siblings who lived in Britain, and there was mutual exchange of help and support between them. From what Chantal and Evadney told Verna, it appears that Evadney was very 'disappointed' with her son's 'unreliable' behaviour towards his new family, that she offered Chantal money and said: 'Go to America with the child. Lionel would never be there for you. He will never be anything for you. Here is some money, go and make a life for yourself'. However, Chantal refused, stating, 'I'll stick it out'. Through her struggles, Chantal kept in close and regular contact with Lionel's family, whom she saw more often than she saw Lionel.

Verna recalled how, when she was a little girl, her mother took her on the bus every other Saturday to visit her grandmother Evadney (they visited her maternal grandmother Myra on alternating Saturdays). Her two young uncles, Milo and Manzie who then lived with 'Big Gran', met them off the bus at the end of the road. Because Lionel often had extended visits with his mother, sometimes when Chantal and Verna hadn't seen him for a while, they would find him there. Verna recalled being both terrified and fascinated by her grandmother Evadney, who also commanded a lot of respect from her grown children, all of whom addressed her as 'Big Gran'.

These regular visits to Big Gran's had a lasting impact on Verna's and Chantal's lives. It was Big Gran who taught Chantal to speak Caribbean patois and to cook Caribbean food. She always cooked a big meal on Saturdays when they came to visit. On major holidays such as Easter and Christmas 'she would put on a feast'. 'Thanks to Big Gran's influence', according to Verna's brother Jude, 'my mum could drop the old patois and cook a mean [very good] rice and peas'.

After dinner, Big Gran would retire to her bedroom until the evening when she got dressed to go to bingo. Her children brought whatever she needed up to her in her bedroom, and she had a stick that she would bang on the floor when she needed something. When they visited her, Verna remembered how it was important that she went up straight away to see Big Gran.

She'd be lying on the bed, and she would have the little tight cap on her head, with a row of wigs on her dressing table. And she'd have her nightie on, and she'd be very big busted, long nails, long talons. She was glamorous. I mean, her dressing table was fascinating to me. There were thousands of bottles and potions,

and then these wigs on heads, and I'd wonder: which one would she put on tonight to go out?

She'd always do my hair, 'cause my mum didn't really know how to do my hair. And I dreaded it because of course, my mum just left my hair. And so she would just sit on the edge of the bed and I would have to sit on the floor, and she would literally lock my head between her knees, and she would get the ultra sheen [hair oil] and a comb, and all the tears. I was terrified! I wasn't allowed to cry, so I'd have to hold the tears in, and my head would be going like on fire. I mean my eyes would be like that [bulging her eyes, laughs]. But then she would plait my hair and then I would love it.

Big Gran also visited the US and Barbados twice a year. Verna recalled fondly how Chantal took her each time to see her grandmother off, whether at a seaport or airport, and how she couldn't wait for her grandmother to return, bringing her beautiful dresses and other gifts. She recalled: 'I'd have a whole new wardrobe, cologne, and hair stuff that you couldn't buy here at the time for my hair'.

The relationships between Chantal and Lionel's siblings are also memorable. Verna recalled that, before her father's sister Jenny migrated to the US with her family, there was plenty of help exchanged in the form of babysitting between Jenny and Chantal. This practice also meant that Verna spent time playing and interacting with her cousins. After Jenny and her family moved to America, she maintained contact with Chantal by telephone and, on her yearly visits to England, she brought presents for Chantal and Verna. After Lionel's other sister Joyce moved to Wales, Chantal took Verna there every summer to spend the school holidays with Joyce. Additionally, Lionel's two younger brothers Milo and Manzie paid frequent visits to Chantal's home. They offered help around the house and took Verna to the movies and to the park. Verna recalled how, during the early years when Chantal couldn't drive, her father's brother Milo 'would come every Friday evening in his little blue Mini [car] and take us shopping'.

### **Moving to Milton Keynes where Jude is born**

In the 1970s, when Verna was eight, Chantal became pregnant with Lionel's second child, Jude. The family moved to Milton Keynes, a developing satellite new town in South Midlands. Part of the move's attraction for Chantal was that they went from a high-rise flat to a 'little house with a garden'. She was very active here in building up the local residents association, the 65+ social club and a play scheme for young

children, thus creating a new network of friends through these activities. With her closer friends, she had an 'open-door' policy just as she had with her family. Verna recalled two neighbouring couples, both of whom were called 'Auntie' and 'Uncle', who had keys to their house, and with whom Chantal exchanged help and support, for example, when it came to looking after Verna.

For Verna, the immediate impact of the move was less positive. Moving from Wolverhampton to Milton Keynes, she remembered 'suddenly feeling different', especially at her new primary school, where she was 'the only black kid', and was taunted by other children who called her a 'blackistani'.

Five months after moving to Milton Keynes, Jude was born. This baby was a 'longed-for son', and Lionel, proud to have a son, stayed home more often with his family. During this time, Verna remembered Chantal sometimes wishing that, 'This [a son] might be what he [Lionel] needs to make a proper life for us'. However, after a while, Lionel resumed his old pattern of coming home only intermittently.

Chantal went to work for one of the construction companies as a secretary during the day and cleaned their offices at night. Later, she took up child-minding during the day, taking care of three, sometimes four, other children. When she worked nights, it was primarily little Verna who took care of Jude. However, the family friends on the estate were always there 'keeping an eye' on both children. When Chantal began working two jobs, her financial situation improved, so that she no longer required financial help from her extended family back in Wolverhampton. She continued to maintain contacts with members on both sides of her family to the same degree and, though she did not drive, she took the children every weekend on the bus from Milton Keynes to Wolverhampton to visit their relatives.

### **Understanding the relationships between the two sides of the family**

Chantal maintained what Verna and Jude recalled as 'quite equal' relationships between her family of origin and Lionel's family of origin. However, forms of relatedness were kept separate between the two families. Although there were mutual contacts between both sets of family – for example, Easter, Christmas and school holidays were shared between the two families – in Verna and her siblings' recollection, as children growing up, family gathering with both sets of families never occurred. With regard to forms of help and support exchanged between the families, despite Chantal's brothers' attitudes towards her choice of partner, they continued to provide physical or practical help and support

to her whenever it was necessary. From Lionel's family she received both practical and emotional support.

Verna and her siblings had their own explanations for the difference in family relatedness between the two sets of families. Jude believed that the difference had to do with the two sets of family's religious attitudes and social-class backgrounds. His father's family were non-religious and came from a lower-middle-class background, while his mother's family were 'strict Catholic' and came from a 'poor' background. Thus, his father's family were 'more relaxed' about Chantal's position, and therefore more able to provide emotional support to her. Verna agreed that her father's family were more accepting of Chantal's position, but thought that difference was not only due to contrasts in religion or social class. At an emotional level, because Chantal's brothers already disapproved of her life with Lionel, the 'fact that she never knew when my dad was turning up, and no one knew where he was from one week to the next' made it more difficult for Chantal to explain her situation to her brothers. Lionel's family, on the other hand, had more sympathy: 'They didn't judge her, and she could go to them for emotional support'.

The differences in religion do indeed seem less important when it is remembered that, in practice, Chantal's father was not a model husband or father himself – an alcoholic who sometimes disappeared for days. On the other hand, in terms of transgenerational influence of kinship patterns, we must note that from Lionel's family, his mother Evadney who provided the most emotional support to Chantal, had five children by four men, two of whom she legally married. Her own experiences may have taught her to be more open to different forms of doing kinship. For, although Evadney recognised that her son would never settle down with his family, she accepted Chantal's situation and welcomed her and her children, while providing practical and emotional support from the very beginning.

### **Crises in the family**

Verna remembered the latter part of the 1970s as the period when one family crisis occurred after another. A year after moving to Milton Keynes, Chantal's father Simon died. That same year a cousin told Verna that her parents were not legally married. Although Lionel did not live with them most of the time, that her mother took his surname and that his 'things' were in her mother's house meant, for Verna, that her parents were a 'married couple'. She thought 'this was the way most families lived'.



He didn't live with us. He had his clothes, he had his hi-fi and his records at our house from as long back as I can remember. And all through my childhood, one day he'd be there, like he might come home from work on a Tuesday evening and be there, and be around, and it would be ... normal, and I'd go to bed and I'd say 'See you in the morning'. And I'd get up and he'd be gone, and I wouldn't see him, he wouldn't reappear for three weeks, then he'd just turn up.

Up until I was about seven, I thought everybody's family was like that. I thought all dads just came, stayed for a few days and went. I never knew it any differently. But I do recall, I have memories of my mum phoning around. She would phone my grandma: 'Do you know where Lionel is?' She'd phone his brothers: 'Do you know where Lionel is?' She would phone friends. I think this is why my grandma said: 'Go. Go to America and leave him'. But to her [Chantal], he [Lionel] was still her man, they were still a couple.

Verna recalls being confused by the revelation that her parents were not legally married, and that 'most families' did not have the same living arrangements as hers. Moreover, from an early age she thought, 'I wasn't going to have a man like that'.

The next year her grandmother Myra (Chantal's mother) died. Verna remembered the sorrow that resulted within her mother's family, particularly her own grief as she had become very close to her grandmother. With Chantal's parents now both dead, Saturday visits to Big Gran Evadney became weekly (as opposed to alternating Saturdays). Now that Chantal worked long hours during the week, Saturday was her only day for weekly shopping. Hence, while she shopped, Big Gran's house became a familiar place where the children could stay to be taken care of by their grandmother and other visiting family members of Lionel's family. At the end of the 1970s, a year after Chantal's mother died, Big Gran became very ill, and was bedridden. 'Terrified' as Verna was of Big Gran as a child, she remembered developing a very close relationship with her during her illness. Thus, instead of the 'painful' experience she remembered of grandmother Evadney combing and plaiting her hair, it was Verna who later combed her grandmother's hair, read the Bible to her and told her stories.

Evadney died the following year, bringing great grief to all her children but, in Verna's memory, to her mother Chantal most of all. Chantal, who at the time had been pregnant with her third child by Lionel, went into deep mourning for Evadney and, a few days after her burial, she went into premature labour, giving birth to baby Kate. According to Verna, Kate's birth was a memorable event that 'replaced

the loss of Big Gran with joy in a short space of time'. Thus, despite the family losses of this period, the 1970s ended with a new addition to the family.

### **New discoveries and awakenings**

There were more family crises in the 1980s, beginning with the appearance of Lionel's father Boysie and his integration into the family, followed by the parting of Chantal and Lionel. Soon after 1980 while Lionel and Chantal were still a couple, Boysie made contact with Lionel for the first time. Recall that Boysie had migrated to England from Barbados, but came independently from Lionel's mother Evadney, and they never lived together as a couple. From Lionel's account, it appeared that, when Boysie migrated to Britain, he never contacted Evadney nor any of his sons (he had Lionel and Milo by Evadney in Barbados; see Figure 5.2). It appeared that part of Boysie's objective for contacting his son was to 'make up for lost time'. However, according to Lionel:

It was too late by then to be a son to him, because all these years I knew he existed, but as far as I am concerned, he could have been any of the old men I see on the street that I pass by every-day. I don't know the man, and I have no feelings for him. Neither love nor hate.

Furthermore, by the time they made contact, Boysie had become 'very closed up', and evaded any questions asked in attempt to find out about his life.

Lionel believes that his upbringing – the lack of a father as a model in his life – is partially responsible for his own behaviour towards Chantal and his children. However, he also said that, although he did not live with his family on a regularly basis, he continued to be active in their lives. Indeed, Verna does substantiate his claim, stating that he was a significant influence in her life, especially in dealing with issues of racial abuse towards her and her siblings and, in particular, he was very involved in her education. Hence, given that Lionel kept in contact with his own children and was active in their lives, in his view, the situation was different with his father. He therefore had difficulty accommodating his father as a member of his family.

With Verna's three other grandparents gone and her father unwilling to accept Boysie as family, what avenue did Boysie, the only remaining grandparent, have into Verna's family? According to Verna, it was her mother Chantal, the main person maintaining the link with Lionel's family, who welcomed Boysie as another important link for her children.

Chantal kept in frequent contact with Boysie, who at this point was living alone, and she took the three children to see him regularly. Approximately two years after Boysie was introduced to the family, he had a heart attack. After he was released from hospital, he needed care and, with no other family member willing to support him, Chantal took him into her home. Six months after Boysie moved in, it became clear to her that he needed more care and support than she could provide. Consequently, she found him sheltered accommodation, and continued to visit him very regularly, with and without the children. In addition, on high holidays such as Easter and Christmas and on the children's birthdays, she brought Boysie home to participate in the celebrations.

### **The parting of a long and complex couple relationship**

Not long after Lionel's father Boysie was incorporated into the family, it was revealed to Chantal and the children that Lionel was involved in another 'significant' relationship with a woman called Sandra. Chantal and Lionel parted as a couple and, although Chantal found the parting 'painful', the couple remained friends. Chantal also maintained her relationships with Lionel's siblings and his father Boysie.

Shortly after separating from Lionel in the mid-1980s Chantal enrolled in university to get a Bachelors degree. It is not surprising that, given her own circumstances, she was drawn to children's social work. With Verna now in her mid-teens, she was able to provide more child-care help to her two younger siblings while her mother studied. Chantal completed her degree within five years and secured a job working with single mothers. She became better off financially and bought a car.

### **Verna leaves home**

In the late 1980s when Verna was in her late teens and running creative writing workshops in Wolverhampton, she met her first partner, a writer named Michael (see Figure 5.3). A year later, she became pregnant and, because she 'always felt different as a black person living in Milton Keynes', when Michael suggested they move back to Wolverhampton, she agreed, moved out of her mother's home and went to live with him. A few months before she gave birth to her first child Damian, her grandfather Boysie died. Thus again, as with the end of the last decade, the loss of one relative was replaced by the addition of another. After Damian's birth, Verna moved back home where she felt 'safe', to live with Chantal for a while. She said that her mother gave

her all the emotional and practical help and support she needed, and taught her everything she needed to know about being a mother. When she felt strong and comfortable enough, she moved back into her home with Michael. Despite Chantal's busy schedule with work and her two younger children, she visited Verna regularly, offering various forms of help and support to her and the new baby.

### **The 1990s: More uprooting, ruptures, family additions and a major crisis**

After the birth of their first child, Verna and Michael's relationship became 'very volatile'. She moved back to live with her mother in Milton Keynes. However, shortly after moving, she realised that she was pregnant with her second child. When she told Michael, he went to Milton Keynes and persuaded her to return to Wolverhampton. At the time, Michael's job was taking him regularly to London and, after their second child Patti was born, they decided to leave Wolverhampton for London.

In London, Verna enrolled in university for an undergraduate degree in English literature. With all her family left behind in the Midlands and no supportive network in London, life became very challenging for the young family. Geographical distance meant that physical contact with other family members was severely limited. However, her mother Chantal found ways to overcome the distance. She called Verna daily and visited her once every month for a few days, and every half-term and holidays, she brought food and other gifts. On occasion, she also took Verna's children to the Midlands to see other relatives as well as to allow Verna some child-free time to study. Whenever Verna's children became ill, Chantal, 'at the drop of a hat' drove to London to care for them. She also insisted on maintaining the relationships between Verna and her siblings despite distance, through frequent visits to London, and by regularly engaging them in phone conversations.

Contacts between Verna and other family members were not as frequent as with her mother and her siblings. Her father Lionel and his siblings telephoned and visited her periodically, and they sent birthday and Christmas presents for her children. Letters enclosed with photos were also regularly exchanged between Verna and her paternal relatives. Among her maternal relatives, there were no such exchanges, and contacts only occurred whenever she returned to Wolverhampton. However, because Chantal maintained contact with her family of origin, Verna was always informed about them. For example, when her Uncle Delroy returned to live in Ireland, it was Chantal who told Verna. When her uncles Errol and Keith and her Aunt Tiny died, Chantal also

informed Verna so that she could return to Wolverhampton for the funerals.

Two years after moving to London, Verna and Michael's relationship had, in her words, 'become intolerable'. The couple parted but maintained 'a friendly relationship for the sake of the children', and they shared in the responsibilities of childrearing.

### **Verna meets Ken and his family**

After Verna separated from Michael, she met Ken at college, and they developed an intimate relationship. After eight months of courtship, Ken moved into Verna's home, where she lived with her two children. Over the next few months, he met various members of her relatives as they dropped by periodically to visit, including her mother Chantal, her father Lionel, her Uncle Milo (Lionel's brother), a cousin, her brother Jude and her sister Kate. Within months of his moving in with Verna, he told his family. The two families met for the first time two years later when Ken and Verna graduated from university.

They had each been given two tickets by the college for members of their respective families to attend their graduation ceremony. Ken invited his mother Eve and his father Tylor. For Verna's family, two tickets proved insufficient, and her whole family showed up. Ken's mother Eve vividly recalled this first meeting at the graduation event.

That was a bit of a shock. We [she and Tylor] hadn't divorced yet, but we were well and truly separated... but there was no problem about that. The problem came when we met up with Ken in his gown, and he's saying 'Verna is over there, I want you to meet Verna, but she is waiting for her family'.

The college normally says two tickets, so Ken had two tickets, and he gave them to Tylor and me. Of course Verna's family don't take notice of tickets, so eventually he said: 'Her family has arrived, now come and meet them'. So there is this group of people, and he said: 'This is Verna,' and Verna came forward and said, 'Oh, I really wanted to meet you'. And she just smiled, and when Verna smiled I just completely melted of course, and that was it.

There was her father with his dreadlocks, there was Jude, her brother, and her sister Kate and there was Verna and her two little black children, and her white mother. So that was one hell of a thing for us to take in right there on the spot. There were just so many people... it was such a hoot, really.

We had to go in, and when we came out of the ceremony, we all

gathered again. They got picnics and Tylor and I wondered around. At one point, Tylor was standing talking to Lionel [Verna's father]. Now Lionel is a fine figure of a man. And after that, Tylor and I went off to have a cup of tea, and he said to me, he said to Lionel: 'Where do you come from?' And Lionel replied, 'Wolverhampton.' 'Ah Wolverhampton, right,' Tylor replied. This is Tylor talking to Verna's father. Anyway, he said: 'Well, I think Ken's got very peculiar taste, that's all I can say'. So I said: 'Well, you can't comment on how other people are attracted. I think you've got very peculiar taste' [implying his choice of partner]. So that sort of shut him up on that.

After that first meeting, Eve recalled feeling 'strange' about the situation and its implications. Therefore, she decided that if indeed this was going to be a 'serious relationship' between Ken and Verna, and one in which she would be included, she needed to explain her background and her concerns to both of them. She took the occasion to explain her position when Ken and Verna invited her to their house for supper one evening shortly after their graduation. She asked Ken whether he was aware of the responsibilities involved in 'taking on a woman with children'. She said that with children involved in a relationship, he couldn't 'just walk away' from conflict, but that he needed to try harder to 'stick at it' and resolve whatever problems may arise. Eve was not only concerned about Ken and Verna's relationship, but also about coping with her own ambivalence over the changed environment she had encountered on her return to live in London. Let us briefly review Eve's kinship history from her own narrative to gain some insight into her feelings.

Ken's mother Eve, a former secretary, was born in the suburbs of London in the mid-1930s. She was the only child of her parents, Veronica, a domestic worker, and Robert, a hospital orderly (see Figure 5.1). As a girl, Eve recalled that her 'working-class' mother had 'middle-class aspirations to gain respectability'. Her mother, having worked as a domestic worker for wealthy families, had 'picked up all the trappings' she observed among the families she worked for and tried to 'pass them on' to Eve. Veronica read the same books to her that were read to the children she cared for, sent her to ballet and elocution lessons and discouraged her from certain behaviour such as standing on street corners talking with her friends. She also occasionally took Eve to shows and classical music concerts. In the late 1940s when Eve was eleven, Veronica sent her to a grammar school for girls that had only recently been converted from a private fee-paying school to a state school and which, according to Eve, 'still had certain aura of the girl's private school'.

When Eve was sixteen, her father retired from work with ill health, and her mother encouraged her to leave school and help support the family. Since she hadn't been enjoying school, she 'didn't mind in the least'. Thus, she secured a job as a secretary in a large industrial company in London and commuted every day to work. After a year on this job, she left the company to work for a design practice. Here she met her husband Tylor, a designer. They married in the late 1950s and moved to London, where they bought a house and had their first two children Maggie and Junior (Figure 5.1).

The mass migration from the Caribbean to Britain in the 1950s and 1960s was already affecting their neighbourhood in South London. For Eve, who 'only saw black people in the pictures on screen, and in books of African tribes where there were always the dirty little boys because they had no clothes on', living in London among Caribbean people was a 'strange' experience. She and Tylor decided to relocate their family to a seaside town in Sussex where their last two children Lucas and Ken were born. She recalled her feelings of ambivalence at the time:

We were living in [South London] in the fifties and, quite suddenly, there was a lot of immigration, and it started impinging on us. West Indian families started moving in, and of course immediately the property value started going down, so you worry a bit about that. And you could tell their houses by the colour that they painted their walls. And they used to sit out on their front door steps, and use their front garden, which was very un-English and the men never took their hats off, and they were always around in these hats, and they were very sinister...I was quite nervous. Strange, not knowing how to behave, nervous...

I didn't know about my husband, I think both of us had every wish not to get involved in colour prejudice. We thought Enoch Powell was dreadful, but most of the black people that I saw around me, we didn't have things in common. So I never met any black people through normal, you know, doing the same things as I did, having the same interests as I have. It just didn't happen...

And then we moved down to Sussex, and when we moved down there, it was like going back in time. And we did do some thought-questioning on this, because we could see that this immigration was going to change areas of London, and we felt we were running away from it. But, really, why we moved was not because of that, it's because we couldn't stand the noise from the neighbours at the back, and the neighbours at the front. It was a very small garden, and it was very noisy, and we just got seduced by this house by the sea where there was no neighbours in front,

no neighbours at the back...But we did talk about it, and did have this feeling that we were going deliberately, moving away from where there was gonna be problems.

Certainly it was quite a heavy influx. But when I moved back twenty-odd years later, I was very surprised to see how in fact, Wandsworth didn't become like Brixton... White people were, at that time, afraid of becoming a minority in their patch. That's what the fear is now [where Asians have moved into white areas] ...And I'm afraid there was a lot of fear about the value of your house going down, because these people that behave in this strange way are moving in. There was a lot of fear.

In the late 1980s, Tylor separated from Eve. By the early 1990s when all their children left home, Eve returned to live in London. She secured a job as a salesperson for a large company. It was now over twenty years since she left London and, upon returning, she found that the Caribbean population had spread even more to various parts of the city. She also had ambiguous feelings about the situation she encountered then.

When I moved back to London, having had 22 years in Sussex ... I'd been living in this very small town, very conservative in every way, and you get used to that. And when I moved back to south London, there was this huge black presence. This is before Verna and I met each other. So coming back and getting used to living alone for the first time...when I moved up here...was the first time I actually lived alone in a house.... The culture was very different. So I was going home and travelling a lot, and there were all these black young men who insist on wearing black, and black baseball cap, and hanging around in groups, and I was uncomfortable, and I was questioning myself a lot about why I felt uncomfortable.

I think that whether I noticed the black groups more than the white groups, or whether there were more black groups than there were white groups of youngsters around at nights, I don't know. But I worried about the fact that I found them sinister. And it's the body language thing, and it's a getting used to a new place thing. And I hadn't worked all that out, and then I'm confronted with Verna. So I told her, I can remember saying that I come from a white middle-class background, and that's been my experience up to now. And I don't think that I am prejudiced, but I am strange with it. So I thought the only way we were going to be able to build on it all is if I was completely honest with her.



Verna and Ken recounted the story Eve told, which, according to Verna, was the beginning of a very 'open and honest relationship'. Over the next sixteen months, her siblings, Jude and Kate, and their mother Chantal were introduced to the rest of Ken's family. However, the extended family dynamics and relationships essentially began to develop after Verna became pregnant and she and Ken had their first child Jonah.

### **Baby Jonah is born**

Jonah was born to Verna and Ken in 1996. At the time, the couple worked flexible hours during the week, and organised their schedule so that at least one parent was home with the children. On Saturdays, however, they both worked, and while they hired a babysitter for the two older children, Eve cared for baby Jonah. According to Eve, she and Jonah developed a 'very special relationship' from this very early age, and she quickly embraced grandmotherhood in a manner she never thought was possible. She spoke of how becoming grandmother to little Jonah brought a new experience to her life, and made her more comfortable living in London again.

I remember pushing Jonah around South London, which is pretty black, and feeling that it's like having a badge. That I was let in somewhere.... I felt really tough, because black women would look in the pram and they would talk to me. So I thought 'Oh, that's nice!' I felt that knowing that family made me a lot more comfortable with all the other black people that I've met since....I am really proud of the fact that I can be part of a black family, that I have this mixture. Yeah, it's something I'm proud of. And I always love to show my photographs of Jonah first, and watch people's faces... The experience of being part of a mixed family has really helped me to feel much more relaxed about everybody that lives in the city.

However, this 'special relationship' that Eve had developed with her grandson was about to be threatened, she felt, when nine months after his birth Verna's mother Chantal moved from Milton Keynes to settle in London.

## Chantal and her children move to London

Chantal's new profession as a social worker gave her the flexibility to move if she wished. A few months after Jonah's birth, she got a job with a London borough's social services. She secured a flat in South London, and gave up her house in Milton Keynes to live in London near her daughter and grandchildren. Her live-in daughter Kate who, along with the baby she gave birth to in her late teens, accompanied her to London where the three would continue living together. Her son Jude had left Milton Keynes when he finished high school. He moved back to Wolverhampton to live with his father Lionel and Lionel's partner Page (see Figure 5.3) because, as he explained, living in an area that was predominantly 'white', 'I just didn't fit in'. He hoped he would feel more comfortable in a place where he was less visible. However, he was disappointed, because according to him, despite the larger Caribbean population in Wolverhampton, he never felt totally comfortable, believing that neither 'black people' nor 'white people' accepted him. Thus, he moved to London a year after Chantal and Kate went, and lived with Verna and Ken for six months until he found a job and his own place to live.

Once Chantal moved to London, Verna saw her mother and her sister weekly, and she spoke to her mother daily. According to her, 'My mum would be the first person I would ring for everything. If I needed to know how to cook something, I would call her. If I needed to talk about the children, about my relationship, I would call her, and she was always there. She became, in a way, my best friend'. To Verna's partner Ken, Chantal was 'warm, very friendly, made you feel at ease, and non-judgmental', and he grew even closer to her once she moved to London. However, Chantal's sudden presence in Verna's nuclear family life was less welcomed by Eve.

Now that Chantal was living closer and could offer various kinds of help and support to Verna and her family, what did this mean for the relationship that Ken's mother Eve had developed with the couple, and even more, the close grandparental bond that she and Jonah had formed? With Chantal now on the scene, and wanting to be active in her grandson's life, Eve recalled feeling 'jealous and insecure' on two levels. She was already jealous of the relationship between her son and Chantal before Jonah was born. According to her:

Ken adored her [Chantal], and I kept hearing how marvelous she [Chantal] was when she first moved down to live with them while she was finding a place of her own. I felt a bit insecure thinking that he [Ken] likes her more than me. Another thing, pictures of Chantal were all over the fridge. Of me there would be the odd

one. Our mother-in-law used to say, 'Mothers of daughters gain sons, but mothers of sons lose their sons'. I haven't really felt that, but there was a little feeling.

Eve also felt insecurities with regards to her grandson. Chantal's active presence in Jonah's life meant that adaptations had to be made in order to accommodate the two grandmothers into the life of their grandson. Eve, who was the person caring for Jonah every Saturday until Chantal moved to London, no longer had this weekly 'advantage', according to her, because Chantal had taken her place.

Concerned about losing the bond that she had developed with her grandson, Eve negotiated with Verna and Chantal to have Jonah on alternating Saturdays. This strategy worked not only for her in maintaining her relationship with her grandson but, eventually in the long run, it helped the two grandmothers develop a very close relationship. They jointly organised weekends with all the grandchildren (Verna's and her sister Kate's children). Additionally, the two grandmothers came together independently of other family members for teas, suppers and going to the theatre. Eve also recalled that they talked about 'everything from their family histories to their current life stories'. According to her, although there were differences in the 'cultural things' they appreciated – she loved the theatre and plays though Chantal did not – in terms of 'life, the universe and other things, we had a lot in common, and we could speak together as women'. They became very close and, as Eve put it, 'we felt as if we knew each other's souls'.

### **Relating to the wider family**

Although Chantal and her children were now all living in London, she continued to maintain active relationships with all her extended family in the Midlands. Her siblings and their families did not come to visit her in London, but she drove up monthly to see them all, often bringing her grandchildren and her children. In between, she kept in touch by phone, including with her brother Delroy and his family back in Ireland. She also exchanged regular phone calls with her ex-partner Lionel and his new partner Page, Lionel's siblings in the Midlands, his sister Jenny in the US and his sister Joyce in Wales. Unlike her own family of origin, Lionel and members of his family also visited Chantal and her children and grandchildren in London. Moreover, family get-togethers with Lionel's family in the Midlands were more regular. Ken remembered attending Lionel's birthday party as an occasion to remember, one that would be 'impossible and unheard of' in his family of origin:

You see, unlike my family where people don't mix after separation and divorce, in Verna's family they keep all their people even after they separate, and there's no long-term bitterness, and they just all get on. That really fascinates me to see how their family operate. And her [Verna's] parents seem to be the key players in keeping the family connections going. For example, Lionel [Verna's father] is now with a woman, Page, whom Verna and her mum and all the family get on with very well. We [he and Verna] like her very much, and she runs a restaurant with Lionel. But then there is also this other woman Sandra, who was the woman he was involved with when he and Chantal separated. Interestingly, this woman has also remained on the scene as an important person in his life. And of course you know that although he and Chantal [Verna's mother] separated years ago, he is still a major part of this family. Verna thinks her parents never stopped loving each other really.

So, like I said, he has this restaurant in Wolverhampton with Page, and we all went up. There was Verna's mum Chantal and me, Verna and the children. There was Verna's sister and her brother, and her sister's little girl Ashley. We were the set from London. Among the set from Wolverhampton were his [Lionel's] two brothers Milo and Manzie and their children. But most interestingly, for me anyway, was that there was also this other woman Sandra, this is the woman I told you that caused the separation between him and Chantal. So there were these three women in his life, all there to celebrate his birthday, and having a wonderful time between them. This would have been inconceivable in my family.

There were also family get-togethers in London, where members of Ken's family of origin often participated. One particular example is the joint birthday of Ken's sister Maggie and Verna's brother Jude, as described at the beginning of the chapter.

Chantal remained her children's main practical and emotional support base. They had keys to each other's homes, spontaneously 'dropping in' without phoning first. Ken's mother Eve had never experienced this kind of closeness among her own kin and, on the contrary, had always encouraged a certain amount of 'space and independence' around family relationships. She found this new experience of such closeness 'claustrophobic'. At times when she gets the spontaneous urge to visit her children and grandchildren, she might call and 'invite' herself but, out of 'courtesy', she would not 'just drop in'. In Eve's view: 'There was a much greater intimacy between Chantal and her children than I had with my children. Everything was very, very close with them. When they weren't together, they were on the phone all the time, and they always

had this habit of saying, “love you” when they stopped’. By contrast, communication between her and her grown children only occurred once or twice monthly. However, within a short time, she had been influenced by Chantal’s relationship with her children. Furthermore, having been influenced by his own observations of Verna’s family, Ken once asked his mother why it was that ‘we never say we love each other in our family?’ Eve says she has changed her views and she now tells all her children that she loves them.

### **Major crisis in the family**

It was now the end of the 1990s, and Verna and Ken’s extended family were experiencing what, for them, was the worst crisis of all. Two years after settling in London, Chantal became terminally ill. Although close and supportive relationships had by now developed between Ken, his mother Eve and Verna’s family of origin, both Verna and Eve said that Chantal’s illness brought the family even closer together. While Chantal was ill at home, Verna and her two siblings Jude and Kate took turns nursing her and Eve visited her regularly. Lionel (Chantal’s ex-partner and the father of her children) and other family members from the Midlands also visited her regularly. Kate recalled that it was Lionel who made Chantal laugh the most: ‘Dad just seemed to bring this magic to her whenever he came’. It was also during this period that Ken and Verna’s brother Jude began to develop, according to Ken, a ‘special brotherly relationship’. During Chantal’s illness, they spent many hours together helping her, then going ‘off for a drink together’, sharing their personal life stories and having ‘lots of laughs together’.

Seven months after Chantal took ill, she died. The events surrounding her death and her funeral remain a remarkable memory for all the family. Although she had kept relationships going between her own and her ex-partner Lionel’s families of origin, it was the first time that these two sets of family gathered together in a cooperative manner. Relationships between the two families had never flourished because Chantal’s birth family felt an ongoing disapproval of Lionel. Her three brothers who were still alive – including her brother in Ireland – and their families all attended her funeral (see Figure 5.2). This was also the first occasion where the majority of Verna’s family of origin came together with her affinal family. Eve remembered the period of Chantal’s illness and eventual death as a period that ‘really brought us together as a family. And the preparations for her funeral was something that gelled it all’. She gave a very moving account of Chantal’s funeral, and how the various strands of extended family members worked cooperatively to make the event a memorable one.

Chantal's funeral was this magnificent event, which was absolutely extraordinary. I mean they are an extraordinary family. And it was one of the most incredible days that I will always, always remember. Dolly [Eve's daughter-in-law] and I agreed we'd get there and make sandwiches, and this is even not consulting much with Verna, 'cause they were dealing with their mother having died. And then Maggie [Eve's daughter] turned up. Maggie is very practical, and she worked out that she would stay behind and look after all the little children that were there.

And then when we went back to the house and the funeral itself was fantastic, really moving, but a celebration as well. Wonderful! The girls [Verna and her sister Kate] carried the coffin with Chantal's brothers...Lionel [Verna's father] was too emotional to do it, but Jude [Verna's brother] did....and when we got back to the house, my family just automatically went into service mode, and doing all the making of the tea and the pouring of the drinks. This was Verna and Ken's house, and Lionel was there. It really shattered him. I can remember him [Lionel] sitting down in the corner and just looking open-mouthed at this event. Because Chantal's family were all shattered really by it, they couldn't do all the stuff. So my family, they just kicked in! We didn't plan it beforehand or anything, and they just all did. It was just wonderful, really.

After spending extensive hours with Verna and her siblings and hearing the endless stories about their two sets of family, I too agree that for the two separate family units to come together in such a cooperative way in the end is indeed 'wonderful'. I see this as a culmination of Chantal's hard work and the influence she has had on her families, so that whether or not her disapproving brothers had revised their opinion of her life choice over the years, in the end, they could join with other members of her extended family to mourn and celebrate the passing of their 'baby' sister. Thus, her funeral could be interpreted as a final reward for Chantal, for the persistent effort she put into the accommodative, adaptive, and innovative ways in which she did kinship, despite the conflicts and struggles she experienced in the process.

### **Verna and Ken marry**

By 2000, with Ken and Verna both working, their financial position improved. They moved out of their rented flat and into their first bought home. Seven years after coming together as a couple and living as a family and two years after Chantal's death, they decided to become legally

married. They invited as many of their relatives as possible from both sides of their families. Following Chantal's funeral, their wedding celebration brought together for the second time, members from both of their families of origin. Eve described the wedding as another cross-generational and cross-cultural experience, which she was 'delighted to be a part of'. It was another occasion where her membership into Verna's family gave her the opportunity to have new experiences that she might not otherwise have had.

She [Verna] dressed the boys in long black trousers, and black waistcoats and white shirts. But it was quite strange for me to see my grandson looking so much like a West Indian child. It was just such a wonderful occasion with Jonah standing there holding the rings. I mean he was happy doing that... Oh, yeah, and the food afterwards! There were all kinds of food. There was English food, West Indian food... for you know that Lionel owns his restaurant, so he had cooked all this delicious food, some of it I had never had before. I was so delighted to be a part of it all.

After the wedding, Ken and Verna reflected on the event. It made Verna aware of how little contact she had had with her mother's brothers and their families since her mother's death. She realised that it was her mother who had 'put all the work into keeping the family connections going. Mum created the family we are today, even what we have between us and my father's family, *she* created, not my father'. Ken also mentioned how struck he was to realise that, outside the nucleus of his birth family, it was his mother Eve who kept contacts and relationships going with his extended family of origin. Thus, since his parents' separation and divorce, he had had little contact with his father's brother and his family. After these reflections, the couple decided thereafter, following Chantal's example, to put more effort into maintaining family relationships in the future.

### **Current family relationships**

With Chantal – around whom family relationships had revolved – now gone, what family relationships did I observe during my fieldwork? Beginning with Verna and her siblings, it was clear that Verna was now the pivotal figure. As the eldest child, she had already been a 'second mother' to her siblings when Chantal was working days and nights, and now had become 'mother' in succession to Chantal. Her house has become the hub of family sociability for Sunday dinner, children's birthdays and Christmas, as well as much informal 'dropping in' and

exchanges of mutual help and childcare. The family also continued to have keys to each other's homes. At the time of my fieldwork, Verna was experiencing problems with her teenage son, so he was living with her sister Kate, and Verna felt he was 'safe' within the extended family.

There is a striking closeness between Verna's siblings, so much so that apart from their partners, there appears to be little space for other friends. Ken (Verna's husband) has become absorbed into this sibling set in preference to his own siblings, whom he only meets with three or four times a year. Verna has also welcomed their younger sister Kate's partner, despite hesitations about his unreliability, a trait that reminds them of their father Lionel. With Lionel himself and his partner Page, there are regular exchanges of visits between Wolverhampton and London. Verna still feels resentment about her father's unpredictable behaviour towards the family when she was growing up but, under Chantal's direct influence, she has decided to 'put the past behind and love him. Take him in not only for himself, but for my family'.

On the whole, there were certain members of Verna's family, such as her father's brothers Milo and Manzie, who, despite minimal ongoing contact, shared a mutual understanding that connections could be activated at anytime, whether just to 'catch up on life' or to request some form of help if necessary. The same was true for Ken and his siblings. There is also regular contact with Lionel's sister in Canada. On the other hand, there is only minimal contact with Chantal's siblings and Ken's siblings, showing how, in these white British families, the legacies of disapproval and divorce have resulted in long-term divided loyalties and fissures in kinship relationships.

### **The incorporation of Eve**

I was particularly struck by the place Ken's mother Eve occupied in their extended family. Although coming from a 'conventional middle-class white' English family, as we shall see, she has gradually adopted many of the creolised patterns of relationships that she first encountered in Verna's family. Eve, who had worked full-time until she retired the year before I conducted my fieldwork, had developed a very busy social life as an artist, and found managing time and space challenging between all the members in her extended family. Although she is very much involved in the lives of all her children and grandchildren, the degree of relatedness she has between them vary, due partly to the complications resulting from separation and divorce in her family, particularly with her son Lucas and his children. Eve told me that, on the whole, because of closer proximity, but also because she feels 'more comfortable' with Verna, she spends most time in family relationships and activities with Verna and Ken.



Eve's relationship with Ken's wife Verna is, in her words, 'special and wonderful'. She refers to Verna as 'my other daughter', a phrase she does not use in reference to her other daughters-in-law. Verna likewise, refers to Eve as 'my second mum', and talks to her more regularly on the telephone than does Ken. Furthermore, Verna and Ken have given Eve a key to their home, a privilege she does not have with her other children.

The close relationships between Eve and Verna's family are also based on the exchange of help and support. Although Verna and her siblings exchange the most help and support among themselves, as a couple, she and Ken do receive practical help in the form of babysitting and financial help from Eve. When the couple is experiencing relationship problems, it is primarily to Eve that they turn for emotional support. Her support does not end with Verna and Ken, but also extends to other members in Verna's family of origin, in particular to her sister Kate. Kate who, according to the siblings, has the most difficulty coping with the loss of her mother has occasionally gone to Eve for 'motherly' advice.

Although Eve has five grandchildren between her four children, it appears she is closest to Ken and Verna's son Jonah, her first grandchild in whose life she has played a very active role since birth. Jonah, who was seven years old at the time I met the family, was the only grandchild with whom Eve had ever spent time alone. From various accounts, she and Jonah had developed a 'special' relationship since he was four months old. Now that he is older, she takes him regularly for weekends as well as when his parents go away on holidays. She also takes him on special holidays and, in London, she takes him regularly to the cinema and to hear classical music at the theatre. Of her grandchildren, it is largely Jonah's photos that one sees pinned up in her home's hallways and on the kitchen walls. Eve attributes this 'special' relationship she has with Jonah above her other grandchildren to the willingness of Ken and Verna to allow her the 'responsibility' and 'freedom' with Jonah since he was a baby – a privilege she never had with her other grandchildren.

Eve also reports having a closer relationship with Verna's niece Ashley, Kate's daughter, than she has with her other grandchildren. Not only does she have more regular contact with Ashley, who lives close, but Ashley gives her 'great big hugs' and calls her 'Grandma', which makes her 'feel a part of Ashley's world'. Despite the different forms of relatedness between Eve and her grandchildren, she has included in her will all the small children in her extended family as grandchildren. This includes Ashley and Verna's first two children who are not her biological grandchildren. In her view, 'they all have full rights when I go and my things are divided up'. Thus, while Eve may wish she could

have closer relationships with her other children and their families, she places them within her own wider family in a creolised spirit of openness – that is, family inclusiveness despite conflict and limited contact – an attitude she has derived from Chantal and Verna.

### **Dealing with Chantal's loss and celebrating her memory**

In *Family and Kinship in East London* (1957), Young and Willmott argued that after a mother dies, 'the first and most obvious effect is that, since her children no longer visit her home, they see less of each other' (ibid.: 78). This argument is a generalisation from a large sample rather than an exploration of particular families. Even Young and Willmott later described the case of Mrs. Firth and her siblings (ibid.: 80), whose situation after their mother's death very much resembles that of Verna and her siblings. For although Verna's mother Chantal is dead, her essence remains alive not just in the lives of her children, but also in the lives of others who came into close contact with her. Furthermore, she has remained alive not just as a memory, but as an exemplary figure whose values continue to influence their behaviour. According to her children, Chantal remains 'a part of us all the time'. They are joined by their father every year in a special celebration on her birthday, rather than on the anniversary of her death. This, for them, is a symbol of her enduring presence.

### **Conclusions**

In Chapter 2, I argued that, although participant observation is a key element in anthropological fieldwork, oral narratives are also important, in that they offer an extra dimension to understanding what we observe. This account of Verna and Ken's kinship history and practice – and how it has developed over generations – could not have been constructed without a combination of fieldwork participant observation with retrospective life stories. It would have been impossible to understand how this family has arrived at its present kinship practice from observation alone.

Inevitably, some unanswered questions remain. For example, because Chantal herself has died, we are left asking precisely why she chose to ignore the disapproval of her own family of origin and to create this dynamic extended family? A second question is why Chantal is so present in the lives of her family even after her death? I believe that they continue to share the experience of her loss, because what they have learned from her is so crucial to them. They have learned innovative

ways of doing kinship, despite: a) family objections and differences in forms of relatedness; b) the challenges of time and space in maintaining family relationships; and c) the effects of break ups and new unions.

A third question relates most directly to the issue of creolisation: from where did Chantal's ideas of kinship practice come? There are very important aspects of this family's kinship that seem very similar to kinship practice in the Caribbean. Most striking is the acceptance of serial monogamy and willingness after a break up to forgive, move on and continue to accept an ex-partner within the kin network. Closely related is the treatment of siblings, half-siblings and step-siblings brought up together on an equal basis, as though they are full brothers and sisters. Other key features are informality of social contact and a willingness to give practical help to even relatively distant kin in crisis.

The key figures in the transmission of these practices are three women: first Chantal and, after her, Verna and Eve. It may at first seem paradoxical that Caribbean practices should be transmitted by three women, of whom two are white and one is of mixed heritage. Moreover, it was Chantal, who came from a white British family, from whom both Verna and Eve learned by example. Chantal probably did draw some attitudes from her own family of origin. After all, despite their disapproval, her brothers did maintain contact and give her some degree of support, albeit at a distance. She also retained an 'obsession' with cleanliness, according to Verna and her brother Jude, from her Catholic background. But there can be no doubt that a very large part of her kinship practice was learned through her membership in Lionel's migrant Caribbean family.

Thus, from the standpoint of creolisation, we can say that Chantal represents a key moment. In Lionel's family, the Caribbean kinship patterns can be seen as reformulations/reconstitutions in a new country. But Chantal, as a white woman, by taking them up and making them her own, was creating a creolised form of *British* kinship. She transmitted this creolised kinship both to her own next generation – above all, in Verna – but also, with Eve, to white British people beyond her own blood family.

**Key to Figures 5.1 - 5.3**

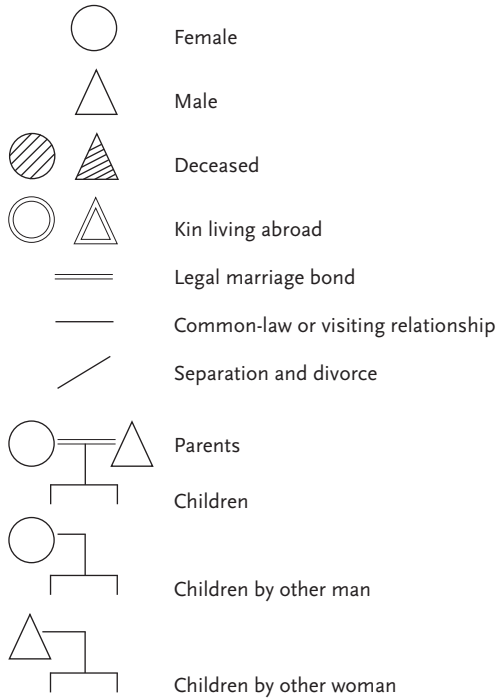

**Figure 5.1** *Ken's family of origin*

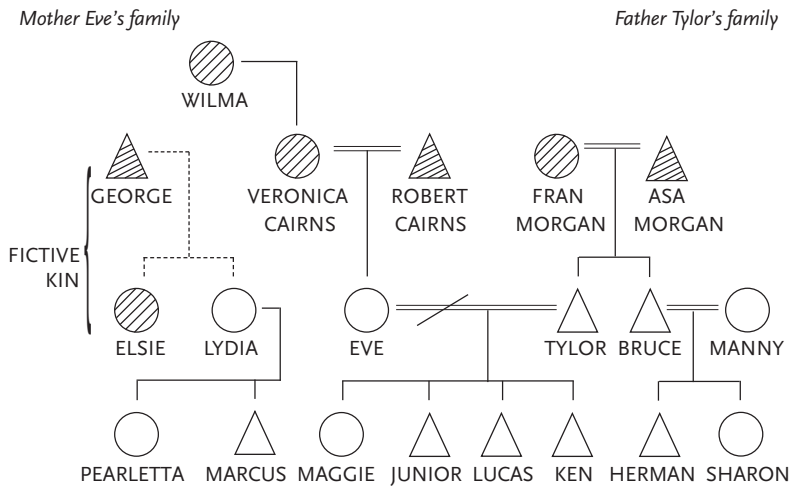

**Figure 5.2** *Verna's family of origin*

*Father Lionel's family*

*Mother Chantal's family*

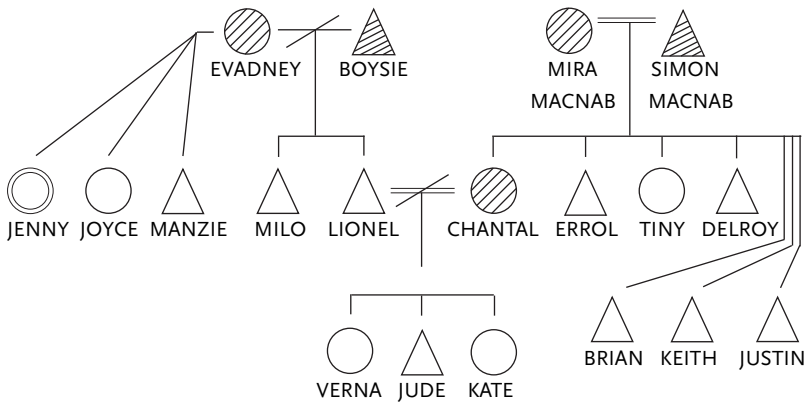
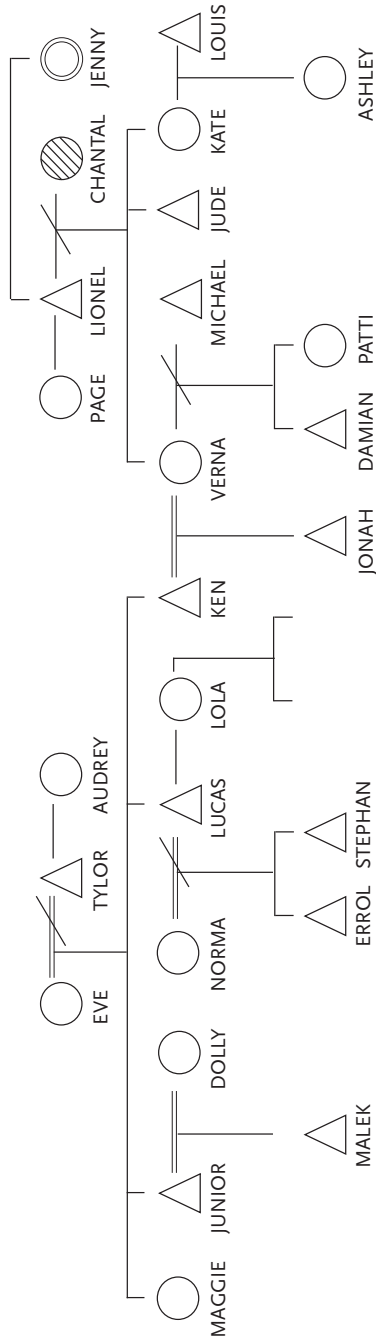

Figure 5.3 Verna and Ken Morgan's extended family



## 6 Mixed sociability and the growth of mixed African-Caribbean and white British families in London

The three ethnographic chapters have so far focused on particular extended families, highlighting the main themes of the book. However, in general, the accounts of people in my research conveyed a variety of experiences. Thus, in these next two chapters, the ethnography will explore more generally the social contexts in which these families emerged, as well as the ongoing modifications and negotiations through which they have responded to changing circumstances, both within the families and in the wider society.

Chapter 1 demonstrated how during the 1950s, outside of workplaces and schools, London had very few places where African-Caribbeans and white British people mixed socially (Glass 1961; Patterson 1965). Today, social mixing in London is widespread, particularly among the second- and third-generation African-Caribbeans and their white counterparts (see Back 1996; Hewitt 1986). In his study of 99 young people in a South London Youth Club, Back observed how

Young people living in Southgate are creating cultures that are neither simply black nor simply white. These syncretic cultures produce inter-racial harmony while celebrating diversity; they defy the logic of the new racism and result in volatile cultural forms that can be simultaneously black and white.

The result is the development of rich syncretic cultural forms that are available to young South Londoners, regardless of origin (Back 1996: 158; on 'multicultural' London see also Keith 2005).

Food is another cultural feature that can transcend cultural and social-class boundaries, and which also requires negotiations, especially within ethnically mixed families. In her study of the relationship between 'food, status and class' in Britain, James (1997: 75) concluded that, 'In Britain food has always served as a marker of class, and continues to do so'. She further argues that:

The embrace of both foreign food and the emergence of a food nostalgia did not represent an emergent gastronomic pluralism

in Britain in the early 1990s. Food, whether foreign or British, continued to speak to older class divides' (ibid.: 81).

However, James' conclusions are not surprising given that her research emphasis was on particular food items.

By contrast, Goode and colleagues (2003), in their investigation of an Italian-American community, look at changes in food consumption along two dimensions: 1) 'the choice of format' (the style of serving food, shaped by the particular social occasion and the structural constraints of the household); and 2) 'the choice of content' (the type of food generated by individual preferences, network specialties, family tradition and resources). They call this process of decision-making 'menu negotiation' (Goode, Curtis & Theophano 2003: 183).

This chapter will show that for the mixed-heritage families in my research, food is just one of many cultural processes that become transformed through cultural contacts in new places.

How have such transformations evolved? This chapter traces the growth of mixed sociability (that is, the social relationships between African-Caribbeans and the white British population) in London since the 1950s, based on the evidence of fieldwork interviews and observations. It maps the spaces and processes in the wider society through which mixed sociability grew and illustrates how such interactions set in motion the subsequent ongoing process of individuals' incorporation into mixed-heritage families.

### **The growth of mixed sociability in London: The starting point, the 1950s**

Based on her Brixton's 1950s research, Patterson (1965) evoked the 'depressing and unfriendly' ethos of London streets and the unwelcoming atmosphere encountered by the first wave of Caribbean migrants.

During the week these streets are full of hurrying, harassed entities, intent on getting to work on time or on escaping from the rain. At night or on a Sunday, the streets away from the city's entertainment centre are empty but for the occasional church-goer, the groups of raucous teenagers waiting for the cinemas to open, and the police. Few people in these London streets have the time or the inclination to stroll or to lean against a building, to smile or sing, or even to bid passers-by good-day.

In such surroundings the coloured migrant feels lost, uneasy, even rejected. If he in addition sees a chalked or painted sign 'K.B.W.' (meaning 'Keep Britain [Brixton] White') or 'Nigger Go



Home' scrawled on a wall, his feelings of insecurity, indignation and rejection are heightened out of all proportion to the actual significance of the sign as an index of widespread local feeling. The great majority of local people will not chalk up such a sign but equally they will not consider it their duty to remove it.

From the local point of view, the presence of large numbers of highly visible and often audible newcomers may serve only to reinforce derogatory preconceptions. Said one middle-aged artisan: 'I'd be frightened to let my daughter walk along Coldharbour Lane alone at night now – there are so many blacks about, the place looks like darkest Africa'... Some local people appreciate the newcomers' cheerful greetings to passers-by, but many resent the uninhibited interest which a loitering group of coloured men will usually show towards a personable female passer-by. (Patterson 1965: 215-216)

From other parts of London, Banton and Glass paint similar views of the social situation during the early stages of Caribbean settlement (Banton 1955; Glass 1961). Essentially, these earlier studies show that social relations between African-Caribbeans and members in the host society during the initial large-scale settlement of African-Caribbeans in London were mostly of a casual nature, occurring on public transport, in public places such as markets and stores, in cafes and pubs, at work and in schools (mostly primary) among the children. These casual contacts were limited, guarded and fuelled by curiosity on both sides yet, on the whole, not welcomed by the host society. However, despite these limited casual contacts, there were also informal social relationships, some of which developed into enduring inter-group friendships, couple relationships and mixed-heritage families.

Dusty Smith from Chapter 3 was among the first migrants to arrive in Britain during World War II as a volunteer in the Royal Air Force. As an eighteen-year-old youth from Jamaica, Dusty felt 'at the time as a member of the colonial Empire, very proud to know I'm coming to England in the Air Force'. From landing in Scotland in March 1944, he was immediately transported with other West Indians to a training camp in Wiltshire. After a few months of training as a dispatch driver, he was moved from camp to camp. At one camp, he recalled that, out of 3,000 men, 'I was the only black man there'. He reminisced about how 'very friendly and jovial' all his work mates were and how they often made jokes about him being the 'only white man' in the camp. On weekends when Dusty was off duty, he went to London in search of entertainment. He lived in the YMCA where, according to him, he experienced no problem in finding accommodation:

You see, in those days, once you had on a uniform, you're accepted. The trouble started when you're not in uniform. When we came here, we was all lads, you know, you had to put on a suit. They didn't care a damn what colour you are. They didn't! It wasn't important, because that uniform you had on was part of *their* [his emphasis] thing. When you get out of that uniform and have to live, and go out and get a job, get somewhere to live, that was really when the problem started.

The 'problem' indeed began for Dusty when he left the Royal Air Force after six years of service, disrobed himself of his uniform and, in 1950, went to live in Stepney – at the time one of London's 'coloured quarters' (see Banton 1955). During this period, the West Indian population was predominantly male. In Stepney, he found shared accommodation in a house with other West Indian and Indian men, who regularly played dominoes, card games and gambled. Dusty recalled how venturing outside for social activities created major suspicion among members in the host society, making him feel 'inferior' in a country for which he had just spent six years of his life in service. Not only would he and his other Caribbean male friends be rejected or treated poorly in the pubs, but, with very few Caribbean women around at the time, their only option was to socialise with 'white Englishwomen'. Although there were Englishwomen who were interested in socialising with them, according to Dusty, they were 'under pressure' from the locals. Socialising with an Englishwoman meant 'going around the corner', and the women were considered prostitutes if they were seen with a 'black man'. As Dusty explained: 'Yeah, that was the thinking: "You're no good going with a black man"'.

Seventy-year-old June also recalled the social atmosphere of London during the early 1950s. As a young Englishwoman who had a relationship with a Jamaican man at the time, she remembered being called a 'black man's whore' and having a really 'hard time' when they were out together in public. She believes that the hostility towards Caribbean people and the riots of 1958 were not simply about colour prejudice, but also deeply rooted in the fear of 'miscegenation', which she suspects, 'has to do with British male insecurity'. Thus, she looks back analytically, and sympathises with the conservative front-bench spokesman for defence. Enoch Powell's April 1968 'Rivers of Blood' speech predicted 'racial violence between black, brown and white peoples' (Goulbourne 2002: 37). In retrospect, June believes that underneath all the uproar over Powell's speech – given the hostility against 'black people', in general, and 'interracial' relationships, in particular – he should have been credited for his foresight and honesty regarding a situation that the 'general government and do-gooders and politicians' had

overlooked in the processes of fulfilling their own agenda: rebuilding Britain in the aftermath of the War. According to June:

From the government policy, it's amazing how blinkered they were. But then that's basically the British denial about sexuality. If you are going to bring a lot of people here to work, and they are mostly men, they too have their needs, but it's pretending that their needs don't exist...The men came to this country as workers, needing to lie down with a woman, and their women aren't around. What are they supposed to do?

June's experience has convinced her that a large part of Powell's fear – 'the black man would have the upper hand over the white man, taking the white man's job, and worse, taking the white man's woman' (Goulbourne 2002: 38) – conveyed the sentiments of most British men at the time. Nevertheless, despite the hostile social atmosphere during this initial period, social relationships between white British people and Caribbean people did develop in London in some spheres (as elsewhere in Britain where the Caribbean migrants settled), although not without struggles. I now turn to those social spaces more in-depth, exploring the changes in social interactions over time.

## **Sociability in the workplace**

1950s – 1960s

Because Caribbean migrants arrived in Britain first to support the War effort and, later, as labour recruits, their first social contacts with white British people were at work. Within the 34 families in my research set, four men came to Britain between 1944 and 1956 to work for the British Army, for London Transport or the National Health Service, and were later conscripted for two years of National Service. All four men reported having good relationships with their workmates in the army and, on the whole, also reported continued good relationships with their workmates in their respective jobs after leaving the army. Only one man, Owen, reported colour prejudice from a work colleague.

Owen had trained as an electrical engineer. After completing his National Service in 1961, he applied for work at a job centre where he was introduced by an army colleague and given a job working with Post Office Telecoms (later British Telecommunications), doing electrical cable wiring on various sites in London. His colleagues were of diverse nationalities and came from various regions within Britain. He remembered 'one English chap [Charlie] who came from way up north, who told me that there was no black people in that part of the world,

and that frankly, “I don’t like black people”. From Owen’s account, it appears that this ‘English chap’s’ view was based on stereotypes of Africans and peoples from the colonies. He spoke of stereotypes mainly having to do with ‘black people as animals and monkeys’ living in trees and their ‘uncivilised’ behaviour. Owen, however, would not be cowed and decided to be amiable to him. Over time when Charlie felt more comfortable with Owen, he asked specific questions relating to these stereotypes. Owen recalled how he would ‘set him straight on the facts’ by telling him that they were ‘myths’.

Although African-Caribbeans and British people worked side by side during these early years without much friction (see Glass 1961: 81-86), it appeared that on the whole, outside of the workplace, they had minimal social contact. This situation was further compounded in the late 1950s and early 1960s by the press reporting of the 1958 London riots, which effectively increased mutual suspicion between both groups (ibid.: 84, 147-211). Fred, a Barbadian, recalled that after National Service he went to work in a hospital and made very good friends with a co-worker, yet they never socialised outside of work. Gertrude, a Jamaican, who came to London in the early 1950s, worked as a nurse in the hospital, and she recalled that she would ‘sometimes have a laugh’ with her British work colleagues. However, they too never socialised outside of work. Furthermore, even now, she does not have even ‘one white friend’.

### 1970s – 1990s

By the 1970s, the post-War immigration from the Caribbean had largely come to a halt. However, among the relatively youthful migrant population that arrived between the 1950s and 1960s, there had been a steadily increasing birth rate. Thus, by 1971, the census estimated there were 244,000 British-born Caribbean people, the majority of whom lived in Greater London (Owen 2001: 64-91).

By the 1980s and 1990s, these children born to migrants had largely joined the job market. While some of the first-generation African-Caribbeans still had limited contact with their indigenous British workmates even into the 1990s, this changed for their offspring. With them, socialising now took place both within and beyond the workplace, leading to many friendships. Furthermore, many individuals from this generation had become intolerant of colour prejudice, so that if there were experiences of racism at work, it usually came from an older person. Thus, in 1987, when Carla (a second-generation African-Caribbean woman married to an Englishman) was refused a job on the basis that she was ‘black’, her English friend, the recruitment officer who recruited her for the job on the basis of merit, challenged the company in court, and Carla was eventually given the job.

## Schools and nurseries

1950s –1960s

Up until the late 1950s, the Caribbean child population in London was still very small because the early migrants were typically without partners. By 1957, the number of West Indian women had risen to equal that of the male migrants, but because many parents who migrated left their children behind in the care of their extended families, it was not until the latter part of the 1950s that their children began to arrive (Glass 1961: 4-6; see also Deakin 1969; Patterson 1965). However, it appears that, in contrast to the very limited mixed sociability of their parents outside the workplace during the time, this minority of young Caribbean children mixed with British children inside the nursery and primary school classrooms as well as on the playgrounds – and without much tension or uneasiness in relation to skin colour (see Glass 1961: 63-66; Patterson 1965: 239).

Indeed, the few individuals in my London research who were of primary school age during this period reported that their experiences in school were overall positive, both in terms of their relationships with their teachers and with their fellow schoolmates. Maggie, a second-generation Caribbean woman, recalled being one of three ‘black’ children in her primary school and the only one in her class. Maggie played with and made very close friendships with some of her English classmates. Although she and her friends never visited each other’s homes during primary school days, their friendships endured into adulthood.

Merna, an Englishwoman, also recalled playing, and making friends, with the only Caribbean girl in her primary school, Sonia. Merna remembered her ‘ignorance’ when she first met Sonia: ‘God, you’ve learned to speak English so quickly!’ To this, Sonia replied: ‘We speak English in Barbados you know!’ Excited about her new friendship with Sonia, Merna went home and told her parents. Her mother was ‘shocked’ at the news, and told her that she couldn’t play with Sonia because she was a ‘different colour’. Merna recalled being ‘very angry’ and ‘confused’ by her mother’s response, but was consoled by her ‘very liberal’ father who told her that she could be friends with whomever she liked, as long as her friends worked hard and stayed out of trouble.

A few Caribbean individuals reported that they felt that their classmates in primary school showed more ‘curiosity’ about their physical appearance and their lifestyles than prejudice. Julie, for example, recalled the battery of questions she received from her classmates during her first weeks in school: ‘What do you eat for supper?’ ‘How do you get your hair like that?’ ‘Oh look at your hands, why are they a different colour than the rest of your body?’ Once Julie ‘enlightened’ her classmates about her background and her physical features, ‘the novelty

wore off' and nothing more was said. Cathy, an Englishwoman, recalled going home and telling her mother about her 'black' primary school classmate whose hands were white inside, and wondering if that meant he was 'turning white'.

During this early stage of Caribbean migrant settlement in London, there was evidently not yet a large number of mixed-heritage children. In my study, there were two individuals born in the early 1950s (Polly and her brother Mark, the children of Dawn and Dusty Smith from Chapter 3) and two born in the late 1950s. Polly and Mark were the only individuals who reported blatant experiences of colour prejudice during their primary school years in the 1950s and 1960s. They were followed, name-called and stoned as they walked home from school. Polly was beaten by two girls in her primary school, and Mark was hit by an English schoolmate. In secondary school, Polly was called a 'half-caste bitch', though Mark reported less hostility, which he thought was due to the greater number of African-Caribbean students in his secondary school than in his primary school.

On the whole, these accounts support Glass' (1961) and Patterson's (1965) findings that relationships in primary schools between the West Indian children and their white classmates between the 1950s and 1960s were, in the main, friendly and without friction. What were their experiences as they moved on to secondary school in the 1970s and 1980s?

#### 1970s – 1990s

From her study conducted in 1970-1971 in Brixton, Benson concluded that the level of 'interethnic hostility' increased when children moved into secondary school, as they became more conscious of the role played by 'race and colour' in the society around them (Benson 1981: 43-44). The accounts of the individuals in my research – as well as those in secondary schools during the time of Benson's research – overall do not convey such a straightforward conclusion. From their accounts, their experiences appear to depend upon a number of variables such as: the African-Caribbean-student-to-British-student ratio, gender and whether they were of mixed parentage.

On the whole, African-Caribbean students who attended secondary school during the 1970s and 1980s reported more hostility from their white teachers than from their schoolmates. The most common accounts are of teachers challenging the Caribbean students' intelligence and requesting them to rewrite their exams. Many talked of teachers who tried to discourage them from pursuing areas of interest that would take them on career paths beyond sports and manual work (see also Bauer & Thompson 2006). Other accounts were of teachers

remarking on Caribbean students' physical features, thereby making them feel self-conscious. Sylvia, for example, recalls her science teacher using her very curly hair that she wore in an afro to demonstrate different types of fluffy clouds.

However, student-teacher experiences during this period were not all negative. Just over a third of my interviewees reported having positive student-teacher relationships, with some teachers providing more encouragement and influence than their own parents. For Maggie who came from a very strict disciplinarian home life, school became a 'refuge'. She remembered school as the place where teachers made her feel 'special' and where she had 'something to contribute'. Anna recalled how encouraging and influential some of her secondary school teachers were: 'They made me feel that I was there on merit, and steered me towards the subjects that would get me into a good university'. Thus, in 1989 when Anna got into the London School of Economics (see Chapter 3), she attributed a large part of her success to her 'white' secondary school teachers.

Pam, a second-generation African-Caribbean female, also gave a striking account of her Welsh home economics teacher who, after a few failed attempts at teaching traditional British cooking to a class of ethnically mixed students, actively encouraged mixed sociability among the students through experimentation with different 'ethnic' foods. In her school, where at least half the students were African-Caribbean, she recalled the first day when her home economics teacher announced that she would teach the class how to make 'toad in the hole'. Not knowing what that was, the African-Caribbean students, almost in unison replied, 'We are not making nor eating any toads!' On a second attempt, the teacher suggested 'Welsh rarebit', to which the African-Caribbean students replied, 'We don't eat rabbits, either!' Eventually, the teacher asked the students what they wanted to cook, and they suggested a variety of Caribbean dishes. Therein, the class was structured in a manner whereby all the children learned to cook both Caribbean and British foods. This story illustrates the transformation of a cultural process as a result of new cultural contacts and through negotiation – a process akin to the process of creolisation.

Some individuals who attended the same primary schools during the 1950s and 1960s maintained their friendships in secondary schools in the 1970s and 1980s, and sometimes also at universities in the 1980s and 1990s. Although at secondary school the number of Caribbean students had greatly increased – in some cases to half the student population – on the whole, the students did not socialise in segregated groups. This was partly because by now many of them had been used to socializing in their neighbourhood streets and on their estates. For example, when Anna went to university, she found it difficult to relate to students

who came directly from the Caribbean because, according to her, 'We weren't the same. I'd lived in London all my life'. Hence, her friends were fellow students (blacks and whites) who, like herself, had been born and socialised in 'multi-cultural London'.

Thus, whether a student had more 'white' friends, more 'black' friends or a mixture of both had largely to do with their common interests. Some took friends home or even on family holidays without any disapproval from their parents. For the few who couldn't take their friends home because of their parents' prejudice, the students rejected their parents' views and remained friends nonetheless.

Where there were reports of interethnic hostility in secondary schools, this essentially involved 'white' youths – boys mostly – calling individuals names such as 'gollywogs', 'wogs' and 'nigga' (on a South London youth club in the 1980s see Back 1996). Petra (a second-generation African-Caribbean woman who is married to an Englishman) recalled being racially taunted by a schoolmate who was a member of a gang of boys and whose parents were known British National Party members. The youth was eventually suspended from school for a week after Petra reported him to a sympathetic teacher. Some African-Caribbean men also reported experiences of racism in their secondary schools between 'black' and 'white' youth gangs. Among these boys, the experience of racism appeared to be strongly linked to the ratio of African-Caribbean to British students. Thus, as the years passed and the African-Caribbean student population increased, the experience of racism decreased. This was partly because, according to an African-Caribbean male named Gus, 'we weren't just sitting back and taking it anymore. In primary school we only had a few black guys in those years, and the white guys dominated. But once we started having more black guys in the school, the white guys begin to back off'.

Interestingly, most accounts of colour prejudice during the period of the 1970s to the 1990s were expressed by mixed-heritage children, mainly in secondary schools, in the form of frequent name-calling such as 'half-caste'. It appears that the issues had to do with, as one such individual put it, 'not being properly black or white', as the hostility came from both 'black' and from 'white' schoolmates.

It was also during this later period at the secondary school level that both English and African-Caribbean children, through their interactions, became aware of alternative patterns of behaviour to those they were raised with in their own families. For some, this was the context in which, through their 'interracial contacts', racist ideas they had been exposed to in their families of origin were interrupted, challenged and rejected (see also Back 1996: 73-98). Amanda and Maggie are two such examples. Amanda grew up in an environment where her English parents' main locus of sociability was the pub. She recalled being taken to



the pub with her siblings from a very early age, and ‘hated it! Absolutely hated it! I hated the alcohol, hated everything about it’. At secondary school Amanda made friends with African-Caribbean peers, with whom she socialised in their homes and at clubs. Through her contact with these friends and their families, she became aware that there was life outside the pub that did not have to involve drinking alcohol. According to her:

As a teenager, my dad was drinking more, and their whole social life was the pub. My black friends’ social life was mainly in their homes, laughing, chatting and listening to music. My friends and I also loved going to clubs to listen to music, but none of them drank, and I loved it. I loved to go out and not see people getting drunk. I can remember thinking: ‘I don’t want to go out with someone like my dad, who is going to come home drunk every night,’ and I associated going home drunk every night with being white, I suppose. Having the friends I had at school made me realise that social life doesn’t have to be all about the pub and drinking.

Although somewhat different from Amanda’s situation, it was also through her friendships at secondary school that Maggie became aware that there were alternative ways to parenting than those she experienced in her own home. Maggie grew up in a strict authoritarian household, where both her Caribbean parents worked full-time jobs and – outside the regular summer seaside holidays, where she and her siblings were given money to play the machines and the amusement rides – the children had no other form of ‘fun’ with their parents. According to Maggie:

We knew what each member of the family’s role was; we just knew that Mum and Dad was Mum and Dad, and that was it. We knew our place, and we did what we were told. We didn’t talk, didn’t play, and there was no cuddling and laughing about things. We sat quietly and behaved ourselves, otherwise we’ll have a smack.

Maggie attended an all-girls secondary school where the majority of her classmates were British. She made friends with many of them, but one special friend was Paula, who was also a neighbour. Maggie visited Paula’s home regularly, and spent most weekends with Paula’s family, because her friend’s home environment ‘was the sort of home environment that I dreamt of as a child. There were people playing board games, the children were doing things actively with the adults in the

room. They would not be intimidated or made to feel they were less than. It was a lovely environment’.

Amanda and Maggie’s situations are not described here because they typify British or Caribbean families, or even such families in the research. Rather, they provide examples that illustrate how second-generation African-Caribbean and British classmates became aware of alternative patterns of behaviour among families, through their interactions in secondary schools. It was partly this awareness that formed the basis for future patterns of behaviour among these individuals when they later became adults and raised their own families.

Interestingly, despite changes in some social attitudes in response to the 1980s riots (see Chapter 7), when African-Caribbean and white students reached universities in the 1980s and 1990s, on the whole, they continued to interact socially. Although, by now, many had been separated from their friends from primary and secondary schools, new relationships were created through liberal friendship alliances partly through sharing accommodation, but most often based on common academic and recreational interests. Some of these alliances were, as Gus put it, ‘so tight, that we never allowed outside influences to ruin our friendships’.

Overall, by the 1980s and 1990s, the African-Caribbean and white British children of the 1950s and 1960s generation had become young adults. This generation claims that, from their teenage years, they felt they had come to share what many of them described as a ‘common culture’. They were joining the same youth clubs, attending the same dance clubs, enjoying similar music, the same food, following the same fashions and having friends from diverse ethnic origins, as well as sharing similar anti-racist views (see Back 1996). As Ann, a third-generation African-Caribbean woman, put it: ‘Our lives became more similar’. As Jane, a 38-year-old white Englishwoman speaking of her second-generation Caribbean ‘high school sweetheart’ who eventually became her husband said: ‘The only difference between me and Richard is that growing up, my family was middle-class, and his family was poor’. This is a difference that she thinks would also be present had she married a working-class Englishman.

## **Sociability in neighbourhoods**

1950s –1960s

Unlike the apparently positive sociability that occurred in the workplace between adult migrants and their English workmates and between their children in schools during the 1950s and 1960s, neighbourhood sociability was of a different nature. My fieldwork accounts

suggest a mixture of hostility with developing friendships. As Glass (1961: 67) put it:

On the whole, English people have an entirely different attitude to their workmates than they have to their neighbours or would-be neighbours. While a man is prepared to work with coloured people, or even under them, he might still be most reluctant to accept the idea that they should come to live nearby. He is far more likely to be aware of their dark skin at home than in the factory.

To begin with, although many West Indian migrants who settled in Britain would have been considered middle-class in their countries of origin, upon arrival, the majority found themselves in working-class positions. Left with very narrow choices of places to live, they were housed largely by friends and families who had migrated earlier in areas close to the London labour market, such as regions stretching from Paddington, through North Kensington and Notting Hill, to Shepherd's Bush and Hammersmith, and also in Brixton, Stockwell and South Lambeth – though not concentrated in these areas alone (Glass 1961: 33-42; Goulbourne & Chamberlain 2001). These were widely scattered areas that had in common a stock of large but neglected Victorian housing, where migrants and transient lodgers from low-income groups could find affordable accommodation. The housing and living conditions of these areas have been depicted by earlier researchers (e.g. Glass 1961: 44-92; Patterson 1965: 171-189; see also Byron & Condon 2008: Chapter 4), and were vividly described by Pam and her mother Jess. As Jess recalled:

In those days, black people were segregated where they could live, 'cause there were a lot of places where they didn't accept black people. And where we were living... one big house, used to have up to five families... Sometimes you have one family in one room, you, your husband and three kids or whatever. Or sometimes you only have one or two rooms. And that's what me and their father and the two older children had. We had one room with two beds. Me and their father slept in one bed, and Pam and Dollard slept in the other bed, and we shared a six-by-six-size kitchen and a bathroom with three other families living in the house. That's what it used to be like back in the sixties.

At the time, some low-income British individuals and families living in the same houses with Caribbeans also shared in the general resentments about what they perceived to be the pressure they put on

housing. Consequently, the local attitudes and reactions towards Caribbean neighbours were seemingly more critical with increasing proximity. According to Patterson (1965: 180), such criticisms focussed on

differences in social and cultural patterns so noticeable as to arouse aversion and even fear, and on the immigrants' general failure to conform to the neighbourhood standards of house-proudness... and quiet and seemly behaviour.

Under these circumstances, it is not surprising that social contact between the migrants and the locals was limited. However, the accounts of neighbourhood sociability from people in my London research were, more generally, either neutral or unfavourable, depending on the person reporting. Susie, an 84-year-old Englishwoman whose three daughters married Caribbean men, recalled the period when the 'many people from different races' started moving into her area in East London during the 1950s and 1960s: 'Didn't take no notice of them. If they spoke, I'd answer. Just, "Good morning, good evening, good night"'. Furthermore, Susie said that, although she had no resentments towards the new migrants, because of the social atmosphere at the time, she believed that there were social pressures on 'white' working-class people like herself and her family from the 'white racists' to dissociate themselves from the migrants. She gave examples of the conversations she overheard at work and among her neighbours that conveyed negativity and disapproval towards the new migrants. This attitude was reinforced by her earlier memories of East End racism, especially against Jews. Already a young mother during the 1930s, Susie recalled how East London then was an area of Jewish settlement, and how Oswald Mosley and 'his fascist men in the black shirts used to cause all the fights and troubles, and put the swastika all over the walls. These were the white racists'. Hence, she had learned from her earlier experiences to keep out of danger.

Merna, an Englishwoman (mentioned earlier) who grew up in a middle-class neighbourhood in West London, recalled that there was one 'black family' living on their street that everybody knew, but didn't remember her parents making contact with them. Conversely, Julie, a second-generation Caribbean woman recalled growing up in North Kensington during the late 1950s and early 1960s, and not being allowed to play in the street and mix with the locals, because her mother feared for her life. Willa, also a second-generation Caribbean woman, showed me the eight-inch scar down her back that she received at age seven from two 'white males', while she was riding her bicycle along her neighbourhood street in East London in 1961. She was taken to

hospital for stitches, and the men who ran off were never charged. She believes that the incident left her with such a deep psychological wound that, outside of the 'white' members in her extended family, she has never been able to form close relationships with 'English people'.

Yet despite the above picture, there was some informal social mixing between the local indigenous British population and the Caribbean migrants during the period of the 1950-1960s. These were contacts with a small number of unattached Caribbean young males and white British women who met in nightclubs (Patterson 1965: 247). Contacts in these common – or neutral – spaces provided the opportunities for some interracial unions, which, in some cases resulted in interracial marriages and families. Dusty and Dawn Smith's case in Chapter 3 is one such example.

By the mid-1960s, with the passing of the Commonwealth Immigration Act of 1962, mass migration to Britain had reached a peak, but the Caribbean migrant population was experiencing high birth rates (Owen 2001: 65-66). Additionally, in terms of housing, 'the pool of generalised white working-class resentment that had been focused and intensified by the 1957 Rent Act, got dissipated by relocation, and by the new buildings stimulated after the 1964 Housing Act' (Phillips & Phillips 1999: 351). Caribbean migrants had begun to disperse, some to newly built council flats, but there was also a gradual upwardly mobile middle-class moving into existing white middle-class areas, and becoming homeowners (*ibid.*: 351). While some moved into their new homes as single families, many sublet rooms to other West Indians. As they began to disperse, there was a widespread belief among many local people that the presence of West Indians in their streets or neighbourhoods caused a devaluation in property prices (Patterson 1965: 171-189), and some actually moved to other parts of London less populated by the migrants, or even away from London.

The accounts of the people in my study convey a variety of experiences. In Chapter 5, we are given Eve's own account of her move from her London neighbourhood to a suburb in Sussex, because she and her husband feared that the value of their property would decrease, as people from the Caribbean started to move in during the 1950s. Donovan (a white British man) recalled that his otherwise 'liberal' parents weren't sure how they would feel if a 'black family' moved in next-door because of the impact it might have on property prices. Donovan questioned his parents: 'How can you say that? That's terrible!' To which his mum replied, 'I'd much rather live next-door to a nice black couple than a horrible white one, but it would still put property prices down'. As it happened, his parents didn't have to move because no 'black family' moved next-door.

For some local British people, the issue wasn't so much about property prices, as much as it was about living next to these 'strange people with their strange ways'. For Manny, reflecting on her mother Margo's attitude at the time, it appears that Margo, who worked in the local dry-cleaners, had no problem dealing with the 'foreign' clients, but living next to them was an issue. Manny recalled her childhood when Jews became the first migrants in her neighbourhood in North London. She remembered the 'general feeling of resentment' towards the new arrivals, especially during and after the war, not only because they were 'foreigners', but also because they were regarded as wealthy: 'The Jews had this, that, and the other. They had cars, they had houses'. From Manny's recollection, 'the Jews were the first people who were picked on because they weren't exactly the same as us'. According to her, by the time the Jews began to move out of her neighbourhood, the West Indians began to arrive in large numbers, and they were picked on as well.

I think mainly because they were different, not because of anything terrible that they'd actually done, but because people of my parents' generation were confronted for the first time with foreigners who didn't look like us, and they didn't know how to handle it. It was perceived as a threat to their way of life.

As it happened, in the mid-1960s a Caribbean family moved directly next-door to Manny's family. Eventually her mother Margo developed 'very close' relationships with her neighbours, and a special friendship with the woman Lolita.

By the time Manny's son Joseph was old enough for primary school in the mid- to late 1960s not only had more Caribbean people moved into their neighbourhood, but people from other nationalities, including Asians, had also moved in. Thus, according to Joseph, for most of his classes, the student body was 'a third white, a third African-Caribbean and the other third of various Asian ethnic groups', and he made friends among all these groups. Manny and Joseph lived at home with Manny's parents and, according to Joseph, the prejudices that his grandparents might have had were no longer evident when he was growing up. He was allowed to bring home his friends without any disapproval.

Lucy's story is somewhat similar to Manny and Joseph's. Lucy (a white Englishwoman) recalled that as a ten-year-old in 1965 when her Jamaican neighbour, Dudley, and his family moved next-door, her father, Charlie wanted to move out of the area. However, her mother Beth was adamant that they should remain. After a few casual encounters, Charlie, who needed some electrical work done to his house, discovered that Dudley was an electrician. Dudley fixed his electrical

problem and, when Charlie offered to pay him, he refused, stating, 'We are neighbours, man, no problem'. Subsequently, according to Lucy, her father became 'neighbourly' towards Dudley though, 'not that friendly, because even that was difficult for him'.

Lucy's family experience illustrates different views on the concept of neighbourliness. While her neighbour Dudley's understanding of what it means to have 'neighbourly' relationships implies reciprocity (see Mauss 1954), it appears Lucy's father does not share the same understanding. Charlie's understanding falls more in line with relationships between 'guests' and 'hosts' (see Benson 1981: 39-50; Patterson 1965: 246-257). In such 'guest-host' relationships, there is an acknowledgement of 'the distinctive ethnic identities of the individuals concerned, and the temporary and situational nature of their shared social activities' (Benson 1981: 48).

While some British neighbours remained and became friends or just 'neighbourly' with their Caribbean neighbours, others remained but kept their distance and some tormented their neighbours in an effort to drive them away. Jenny's family experience is relevant here (see also Dusty and Dawn Smith's family in Chapter 3). During the mid-1960s, Jenny's parents had managed to save enough money to buy a house in West London. They were the only 'black family' living in their neighbourhood during Jenny's entire childhood. She remembers it being, 'just hell! They [their neighbours] made our lives hell!' Her family received endless 'racist' leaflets through their letterbox, and their windows were smashed several times. The worst for Jenny was the morning she woke up to find her cat dead in front of her door with a racist note strung around its neck. Under these circumstances, it wasn't surprising that there was no socialising between her family and the neighbours. This confused Jenny, because being the only 'black' child in her school, she socialised with her 'white' schoolmates without any problems. However, at home, all the socialising was with family and other Caribbean people.

Despite these neighbourhood experiences, during the early stages, some of the most significant and intimate relationships developed from social interactions that occurred between neighbours from both groups. Seventy year-old Jada's experience is of relevance here. Jada, who during the time of my fieldwork was the sole white English member of the Windrush, a club for retired Caribbean elders, told me how she met her Jamaican 'sister' Dolcemina and subsequently became the member of a 'mixed family'.

Jada had grown up in South London, remained there and raised her family with her husband Lester. In the mid-1950s Dolcemina and her Jamaican partner bought a house a few doors down from Jada. At the time Jada was pregnant with her third child, and she noticed that

Dolcemina, who was pregnant with her first child, passed by her door everyday on her way to work. One day the two women 'bumped' into each other, and Jada invited Dolcemina into her home for a cup of tea. The two women quickly developed a close friendship, and when Dolcemina and her partner decided to marry before the birth of their baby, she asked Jada to be her bridesmaid. When Dolcemina was ready to deliver her baby, her brief labour prevented her from reaching the hospital on time, and Jada, who was a nurse at the time, delivered her baby at home. Consequently, the two women developed what Jada described as an 'inseparable bond to this day', and they consider themselves 'sisters'.

The situation between Jada and Dolcemina illustrates a relationship that is based on shared understanding – and contrasts with the experience we saw earlier between Charlie and Dudley. From a spontaneous invitation for tea, the two women developed a friendship and an eventual 'sisterhood' (according to Jada), which continues to operate on reciprocity and mutual obligation (see Mauss 1954). Their sisterhood was formalised with Jada becoming the godmother of Dolcemina's child.

#### 1970s – 1990s

In 1970-1971, when Benson conducted fieldwork in Brixton on twenty 'interracial households' and 'the impact of racial divisions upon their lives' (Benson 1981: vii), she described the relationships between individuals of different ethnicities in Brixton as relations between strangers, 'albeit strangers who might well live in the same street or work in the same factory' (ibid.: 48). Additionally, she characterised the nature of social interaction that did develop between individuals across ethnic boundaries, as interactions between 'guests, hosts and marginals' (ibid.: 48-50). As the previous section shows, this situation was the experience for some individuals in my London study during the 1950s to 1960s. However, I was also interested to determine to what extent such experiences were common from the 1970s onwards.

The scattering of the Caribbean population that began in the 1960s continued in the following decades, so that, by 1991, Caribbean people were found to be living in practically all the London boroughs – though some areas showed higher concentrations than others (see Owen 2001: 73). Thus, not only had African-Caribbeans and indigenous British people continued to work side by side, but there were now more of them living cheek by jowl. By the 1970s, the children of the first migrants had reached secondary school age. In all these contexts, social interaction between the two groups increased. There was also more social mixing between African-Caribbeans and their British neighbours. To a large degree, this contributed to the ease with which the children of



Caribbean migrants and their indigenous peers were able to socialise in their schools between the 1970s and the 1990s. Pearl (a second-generation Caribbean woman), born in 1975, offered a vivid image of life growing up on an estate in South London.

Where we lived, it was very mixed. There was no group that wasn't living in the blocks around, so it was very multicultural. And obviously, most of the kids that were on the estate where I lived, went to the same school, so it's like you knew somebody who lived up there at number 44, or across the way opposite you. You knew their family, you always knew someone or met someone that went to the school, and who had brothers and sisters that went to the same school, so it was like a massive area of different groups of people. When you live in blocks of flats, you tend to find that, with the kids, they all tend to bond together.

I've always been used to the mixture. I've never really had the problem of racism in my face, personally, from that era. I think there's one instance when my mum said that ... I was at nursery, and I came home crying, and she said: 'What you crying for?' And I said: 'Because Susie doesn't want to play with me, because I'm black'. And she just went, 'Right. Fair enough'. And she basically pushed me in front a mirror, and she goes, 'Yes, you are black. There's nothing you can do about it, so get on with it'. And that was that. She never made an issue of it.

I didn't understand what the deal about being black or being white was all about. And my friends ... my best friend is white, and I have black friends, but I also have white friends, and I never saw an issue with that. Never saw an issue with that. I wasn't brought up in a tribe of people, a collective of people who were all black. I've always had a diverse group of people around me. And as I said, my mum would never use race as an issue, and neither did my dad.

Evidently, the degree of social mixing in neighbourhoods relates to the local social composition. Pearl's experience is typical of individuals who grew up in neighbourhoods with people from diverse ethnic/cultural origins, which had become a very common situation. The social mixing that occurred was not just among the children playing out in the streets, but also among their parents in each other's homes. Furthermore, in many cases, the children were the catalyst for social mixing among their parents, because they brought their friends home, and their friendship contacts often initiated contacts between their parents.

In areas where the residents were predominantly white British, the situation was more complex. It ranged from no social exchanges

between the two groups, to minimal contact in the streets in the form of pleasantries – such as ‘hello’, ‘good morning’, etc. Here, too, however, in few cases, neighbours developed close friendships despite their initial attitudes towards each other. An example is Merna (a white Englishwoman), whose mother Lisa disapproved of her playing with her African-Caribbean friend in primary school in the late 1960s because she was a ‘different colour’. In 1980, at age sixteen, Merna met Floyd, her first ‘important’ boyfriend at a youth club, and her mother again disapproved because he was ‘black’. This created a conflict and Merna left home when she was seventeen. Floyd’s Uncle Peter, who had married an Englishwoman, also lived in the neighbourhood, and they frequented the same pub as Merna’s mother. Over time, Lisa and Peter became such ‘close friends’ at the pub, that by the late 1980s, when Merna was able to introduce her African-Caribbean partner to her family, Lisa had become more tolerant of non-white people.

## Leisure and social activities

### 1950s – 1960s

Despite a minority of ‘anti-coloured’ organisations with slogans such as ‘Keep Britain White’ during the initial period of Caribbean settlement, the official attitude of ‘Keep Britain Tolerant’ could be summed up as supporting ‘interracial harmony’ (Glass 1961: 193). Furthermore, attempts were being made to promote tolerance. By the late 1950s, a few upwardly mobile West Indians had joined long-established organisations such as churches, political parties, trade unions and student organisations, as well as sports, jazz and other social clubs (*ibid.*: 195-195; Patterson 1965: 240-254). After the 1958 riots, there emerged ‘interracial’ social organisations set up both by ‘white’ and ‘black’ sponsors aiming to integrate West Indians into British society. However, with a few exceptions, whereby activities such as jazz, dancing, cricket, dominoes and billiards attracted some West Indian migrants, these organisations were not successful. And despite the ‘interracial tag’, only a few ‘white’ members participated (*ibid.*: 242-243). This could partly be related to the degree of welcome ‘white’ people felt they received at these clubs. Karen for example, recalled frequenting a West Indian club in the mid-1960s as a teenager with three of her friends, and not feeling welcomed ‘as the only white persons there’.

On the other hand, as Patterson notes, many migrants had radiograms and preferred to listen to their own forms of jazz and calypso music at home, or in one of the ‘coloured’ clubs that were then mushrooming (*ibid.*: 240). Similarly, for my research participants, social mixing took place largely in ‘black’ clubs and in the form of house parties

at Caribbean homes because, as one couple said, 'this is where we felt safest'. Indeed, up until the late 1970s, house parties were the prime locations from which many enduring friendships and also mixed relationships developed (the Smiths house in Chapter 3 provides a good example). Thus, house parties may be considered primary seedbeds for germinating the dynamic and complex family forms I came to observe during fieldwork. Jada (a white Englishwoman), for example, became part of a mixed-heritage family through her encounter with a Jamaican man, Harold, whom she met at a house party hosted by her fictive sister Dolcemina and Dolcemina's husband.

Dolcemina's husband George had brought his very large sound system with him from Jamaica to London. In London he played music at parties in his own house, and in the homes of other Caribbeans. The couple hosted parties as a means of supplementing their income. Jada enjoys dancing, and she went to numerous parties with Dolcemina and found the experience 'very romantic and dramatic'. One night in 1962, she met Harold, who had arrived that day, 'fresh off the boat from Jamaica'.

Harold had left his two boys in the care of relatives, with the intention of later having them join him in London. Upon arrival he went to live with Dolcemina and George whom he had known from Jamaica. Harold soon became friends with Jada and her family also, and at Christmas she invited him to join her family for dinner. By now Jada and her husband Lester had eight children. After dinner, when the family retreated to the front room to open Christmas presents, she noticed that Harold was missing. She found him crying in the kitchen and asked him why he was crying. He replied: 'I wonder what my kids are doing today?' That night she consoled him by telling him that she would do whatever she could to help get the children to England by the next Christmas. This was the beginning of what became a deep personal friendship between them. After Harold left, Jada called a 'family conference' with her husband and their eight children to discuss what they might do to help Harold. She persuaded her family to help sponsor Harold's sons.

Still working as a manual labourer and living in one room of his friends' house, Harold was unable to save up enough to pay for his sons' passages, let alone provide them with accommodation. However, between Jada, her husband Lester and Harold himself, the three saved enough to bring the boys to London in time for the following Christmas. Upon their arrival, the boys lived with Jada and her family, an arrangement that was supposed to be temporary until Harold saved up enough to get a bigger place. However, after a few months, it became apparent that Harold would not be able to move into his own home any time soon. Jada decided to keep the boys and foster them.

Jada's children were already accustomed to mixing socially with their Caribbean neighbours. Having the boys living in the family home required some adjustments, yet from several accounts, the initial adjustments among the ten children posed the least challenge. It was the relationships between the children and their parents that proved more challenging. Harold's paternal role had now also been extended to Jada's other eight children and to his sons. Harold and Lester both became 'Dad' and Jada became 'Mum'. This situation was perplexing for the children, but eventually they did establish relationships with their parents in terms of parental roles. Jada's family story thus illustrates how, between the 1950s and 1960s, despite prevailing public opinion, African-Caribbeans and white British individuals did come together through innovation and experimentation to form lasting friendships and mixed-heritage families.

#### 1970s – 1990s

By the 1970s, with the drop in Caribbean migration to Britain, there was also a decrease in public racism. Additionally, a series of Race Relation Acts (1965-1976) legally banning racial discrimination in public places (see Goulbourne 1998: 101-103) resulted in more recreational spaces that were accessible to both blacks and whites, such as dance clubs, local pubs and youth clubs. However, as Chapter 7 will show, the social climate of the 1980s (on a series of riots between young blacks and the police see Hiro 1991; Solomos 1993) brought a resurgence of hostility from whites towards blacks. Meanwhile, there was black resistance towards forming alliances with whites, with some from both groups disapproving of mixed relationships and marriages.

Nevertheless, while some blacks became 'militant' – influenced by Black Power and Afrocentrism – and only socialised among their own group, others saw segregation as supporting racist dogma, and continued to socialise in ethnically mixed public spaces. For some individuals, this caused problems both from whites and blacks. Albert, a white Englishman, remembered his favourite nightclub in London's East End, which he and his two 'black friends' frequented during the 1980s. Although this club was ethnically mixed, according to Albert:

We'd get in problems with black guys because they didn't like them being with me, or we'd get into problems with white guys because they didn't like me being with them. But, you know what, that was their problem, because I believe racism has only ever caused pain. It can eat you alive. I want no part of it.

Some young black adults defied their 'restrictive Victorian upbringing' because they felt this model 'did not fit' in 1980s London entertainment culture (for example, punk and the New Romantics). These individuals found themselves socialising in social spaces that were mainly inhabited by their white counterparts. In doing so, some were seen by their African-Caribbean families and friends as 'abandoning' or, as Becky (a second-generation African-Caribbean woman who was raised by white foster parents) put it: 'rebellious against my black culture'. Others felt the need to abandon the notions of group identity that they felt had been imposed upon them, even though their agencies of socialization were by now influenced by both African-Caribbean and white British communities. During the 1980s, Jenny, for example, who had been studying to become a social worker, was working as a community service volunteer with homeless people around London's West End. She embraced the 'alternative culture' she had found through her work, much to the 'embarrassment' of her family. According to Jenny:

Working in the West End had a profound effect on me. I got attached and fascinated by the gay scene. I'm not gay myself, but I love that world. It was seedy, it was going against the norm, it was friendly and unpretentious. I love the lifestyle. I love the gay men I came across, as well as the lesbians – there were black gay men, but the majority was white, so I was mixing mainly with white people. I felt comfortable being in that setting. It was so far removed from my rather restrictive and conservative upbringing.

I think my parents' generation is so conservative. In my family when I was growing up it was all different. My parents' siblings all came to England and they all lived together and had the same friends. My dad was in a steel band with my uncles, so they hang out together. The women would be talking and the men would be playing dominoes. There wasn't many clubs in my mum and dad's generation so there would always be parties in our house. My parents' house was the house to have parties. The parties would be with all their friends and all the people that came from Barbados with them.

And there was I, I was a punk, this black woman with dyed blonde hair, these amazing zipped clothes. I was a real rebel, and my mother couldn't cope, my brothers were just embarrassed by me...call me a 'whore' for going out with a white man. I'm talking about in the early eighties. You didn't see that many black women who adopted that kind of alternative lifestyle, and many places I would go, I would be the only black woman there...I was into my punk music, then I became a New Romantic with

Duran Duran, and went to all these very sort of eighties clubs, dressing up in these sort of New Romantic make-up and boots... I looked like a slut, I think, on some occasions, with my fishnet tights and boots [laughs].

I just didn't relate to my parents' generation from the Caribbean. I wanted to get away from West London, 'cause everybody was... you know, I would walk down the road, I could see my aunt, I could see ... you know, it was so intense! People would see me down our street and tell my mum, "Oh, I saw Jenny with this white man you know!" To which my mother would respond, "You sure is Jenny?" And they would say, "Yeah, 'cause Jenny is the only black girl around with gold hair".

When Jenny met and 'fell in love with a white man' named James, her mother was very disapproving of the relationship. Her mother would say: 'Jenny, don't you bring a white man in dis house you hear me!' Her brothers' reaction was: 'What you doing to with a blood claat [very unpleasant Caribbean swear word] white man?' Of James they asked: 'What you doing to my sister?' Her family's behaviour made it impossible for the relationship to continue.

In retrospect, Jenny felt that her family had 'just reason' for their resistance to her white boyfriend, because of the experiences they suffered at the hands of white racists in the 1950 and 1960s. Hence, she acknowledges the existence of racism, but her own experiences of mixed sociability at the time did not equip her to understand their behaviour towards her boyfriend. Jenny did eventually leave home and, like Becky, by 'abandoning' her 'black culture' for an alternative 'white culture', she said that she experienced prejudice from the 'black community'.

Although individuals like Albert, Becky and Jenny were aware of the existence of racism in London/Britain as young adults, through their mixed socialisation, they have managed to interrupt the reproduction of racist ideas (see Back 1996: 123-169). As Becky said, 'racism is wrong no matter who it is coming from'. Hence, they denied the importance of colour in forming friendship relationships. Moreover, other white and black individuals continued to visit mixed dance clubs, local pubs and youth clubs and continued to form friendships and relationships. Consequently, by the 1990s, statistics showed the highest percentage of interethnic group partnership to exist between second-generation African-Caribbeans and their white British counterparts, with the largest numbers in London (see Chapter 1). On the other hand, as Chapter 7 will show, due to the racism of this period, some people – especially individuals in mixed relationships who are visible targets for racism – remained cautious about the places they went for entertainment. They

tended to form friendship alliances and socialise either with liberal people or with people in similar situations like themselves.

In sum, this section has shown how mixed sociability between African-Caribbeans and white British people could result in innovative forms of relationships, whether originating from juxtaposition as children at school, as colleagues at work or from encounters as neighbours and through leisure activities. It was within these slowly growing interactions/experimentations that mixed relationships developed, such that, from the 1970s (and earlier for a few), there began a gradual increase in mixed-heritage families among African-Caribbeans and white British individuals in London. Furthermore, this process of social mixing has continued despite continuing social prejudice discouraging its development. For each time new intimate relationships evolve, contacts are made with the individuals' wider family and friends, which often set in motion further mixing. And with the arrival of children and grandchildren, a further incorporation takes place into the wider mixed-family network.

This cumulative process of family incorporation is not unique to the mixed-heritage families in this research. What is striking about these families is the nature of the process of incorporation. To begin with, individuals have had to struggle to devise strategic and innovative ways to overcome societal or familial prejudices at the start of their relationships. Equally, for the kinship network to function, individuals have also had to negotiate and adjust in order to accommodate differences in cultural and familial upbringing and expectations. Moreover, these strategic and innovative practices often maintain family and kin relatedness even after separation and divorce. I move on now to describe mixed sociability as I experienced it during my fieldwork in 2002-2003.

## **Current sociability**

### *Sociability among neighbours*

Most of the families in my research had become established by the 1980s. During my fieldwork, I was forever struck by the dynamic, borderless and flexible degree of social interactions, social exchanges and forms of family relationships that existed among individuals in the families as well as among their friends. To begin with, it was unusual to arrive into a neighbourhood and not find it peppered with a mixture of peoples from diverse national origins – Caribbeans, British, Africans, Asians, etc. As I moved through front doors and into back gardens and yards, I was further struck by the number of families without dividing fences running between their property and that of their neighbours, who were often either African-Caribbeans, white British, Asians or

some combination thereof. Not only were there no boundaries between many properties, but a few neighbours exchanged services such as gardening and lawn mowing.

Lucy, for example, is an English mother with three children of English parentage and two children of mixed English and African-Caribbean parentage. She lives with her family in north-west London on a corner lot, with elderly African-Caribbean neighbours to her right. The scene in her back garden is not common among others I saw: even families without dividing fences usually maintain some division such as separate flowerbeds. Between Lucy and her neighbours, however, not only is it impossible to find even a shrub that demarcates their property boundaries, but they have jointly constructed a shared back garden and a barbecue pit. Additionally, there is a brickwork path leading from her back door to her neighbours'.

To an outsider, the scene conveys an instant sense of familiarity between neighbours. On the weekends when I visited, I experienced a constant bustle of activities with Lucy or her son mowing the merged lawn, while her two younger daughters and the neighbours' grandchildren ran in and out of both houses in play. Naturally, my curiosity led me to inquire about the extent of the relationships between neighbours. Lucy explained that the lack of a fence between the houses means that both families can enjoy the whole space. She said that growing up as an only child in her middle-class family made her feel that 'there was something missing: the love and the warmth of people around. But I've built that up now, I have found that right here with the people around me'. Not only is Lucy familiar with her immediate neighbours, but as we walked along hers and the neighbouring streets, she appeared to know everyone she passed with a similar kind of familiarity. I asked her how she came to know the people in her neighbourhood, and she explained that there is a 'strong community spirit' in both streets. This 'community spirit' apparently blossomed a few years back when individuals in the neighbourhood got together to protest against commuter parking for the nearby train station.

Thus, instead of past situations whereby some British neighbours moved away from their 'strange' Caribbean neighbours, the relationships I observed among neighbours were not those 'between migrants and hosts' (Patterson 1965: 215-224), but relationships that were in constant 'rhythms of exchange' (Stack 1974: 40-44). Not only do neighbours socialise in each other's homes, but nearly all the families share spare house keys mutually with their neighbours 'for emergency situations'. For many, it is to neighbours that they first turn in cases of emergency. Relationships between neighbours, particularly those living on estates, extend far beyond leisure activities and helping out in occasional emergency situations, to regular exchanges of childcare, picking



up children from school, small food items, and small money loans. I first became aware of this depth of exchange relationship between neighbours on my second visit to Petra's home on an East London estate.

Petra is a second-generation African-Caribbean woman who lives with her English partner and their three children. One Tuesday morning I arrived at her house and found her alone with her sixteen-month-old baby. Her two older children were at the nearby primary school. At around three in the afternoon I remarked that I should be leaving so that she could get her children from school. She told me that there was no need to rush, because it was Pearl's (pointing across the road) turn to pick up the children from school that day. When Pearl, a white Englishwoman, arrived with her three children and Petra's two from school, I soon learned that there was a network of young families living on the estate, who lived away from their extended families of origin. They looked out for each other and helped each other as a regular practice. Since my experience with Petra, I have subsequently observed this practice among other families, especially those living in council housing.

#### *Leisure activities*

Outside of the social interactions among neighbours, there is, for some families, neighbourhood activities that are set up and run jointly by British and African-Caribbean individuals, as well as other locally organised community/neighbourhood activities. These include: a children's weekend activity group in the local West London community centre of which Lucy is actively involved, a Church of England monthly bazaar in East London that Lorna, a first-generation migrant Caribbean woman runs with her white committee members, the volunteer organisation in Central London in which Owen is an active member, and the women's group in South London to which his wife Babette belongs.

I was particularly struck by my experience at a party held at the Windrush, a club for retired senior African-Caribbeans. Jada became the only white English member of the Windrush Club several years ago through her activities on a local project, conducting life story and reminiscence work on artefacts and foods that Caribbean migrants brought to Britain. The members of the Windrush were so impressed with the outcome of the project (in the form of a booklet) that they invited her to join their committee. She declined on the grounds that she wasn't Caribbean. Though after much persuading, she became a member and is now a very active club fund-raiser and events organiser.

In mid-December 2002, Jada invited me to the Windrush's annual Christmas luncheon. I arrived there expecting only to see the seniors,

but found instead three generations of African-Caribbeans and white British people packed in a room filled with long tables and chairs. Many of these seniors were the same people Jada had told me about earlier: people she danced at house parties with in her youth, the men who offered her drinks and the women with whom she visited maternity clinics and waited outside schools for their children. According to her: 'these were the people with whom I've grown up and raised our children together for the last 45 years'. There were the seniors' children and grandchildren, their friends, and the local councillors. Many of the children of the Caribbean migrants had now become members of mixed-heritage families, and had brought with them members of their extended families. Most people seemed to know each other. After lunch, the tables were cleared away and some old Caribbean music was produced. A couple of songs later, Jada and an 80-year-old Jamaican woman named Selma began to dance. The synchronised rhythmic movements of the elderly women conveyed a sense that they had danced before, and that Jada was familiar with Caribbean music. After their dance I asked Selma which of the two had taught the other to dance. She replied: 'Who knows! Jada has been one of us for so long now, it's hard to say'.

The experience of this event was for me, akin to that of a film that had been fast-forwarded 50 years into the present. I felt as though I had experienced – in one day and in one large room – the culminated development of social relationships between people that had taken place over decades, across generations and through social and personal struggles. I wondered how it must have felt for the Windrush Club members who had lived the experience from the beginning up until the present. However my impression of the event, based on the accounts of the past, was that these were happier and more comfortable times for them.

In the main, in the current context with no colour sanctions on recreational spaces (see Chapter 7), the people in my research said that they feel more secure in most places. However, because prejudice and discrimination do continue, they tend to be selective in their choice of places for leisure activities. They continue to have house parties – and their friendship networks consist of individuals in similar positions to their own – because this is still where they feel most comfortable.

### *Sociability in schools*

While I did not make observations in any secondary school, I did my observations in primary schools, which occurred when I accompanied mothers to collect their children. The schools I visited had a very ethnically mixed student population. Mothers from all ethnic backgrounds chatted casually and friendly with each other while they waited for their

children, and as the children rushed through the doors – many holding hands – they cheerfully bade each other goodbyes. From the sleepovers and home visits among children in the same schools, it was evident that children made important friendships with their schoolmates.

### *Mixed-family sociability*

Mixed families in themselves provide an important context for mixed sociability. For example, in the majority of the research families, there are at least two individuals from both African-Caribbean and white British backgrounds who have partnered with individuals from the other group, thus expanding within their own families the possibilities of mixing between the groups. In Kelly and Patrick's family, for example, the former and three of her sisters have married white British men and the latter's uncle is also married to an Antiguan woman. Hence, the families that I encountered were made up of intricate webs of connections and complex forms of family sociability and relatedness, something that all the ethnographic chapters in this book have thus far illustrated in varying degrees. Here, however, I will offer a more general view of mixed family sociability as I observed it.

Overall, factors such as growing family size, cultural differences, colour prejudice, family conflicts and individual lifestyles can place limits on cross-family sociability. However, some families do manage to bring together extended relatives from both their African-Caribbean and white British families, thus enabling extensive social mixing. During my fieldwork, outside of the usual family interactions within homes, I attended numerous family functions, including one funeral, three weddings, four christenings, numerous birthday parties, house parties and Sunday dinners – events where family members come together in large numbers. For example, Rose, a white British woman, and her husband Raleigh, an African-Caribbean man, regularly have house parties with their extended families from both sides. In Chapter 3 we find Dawn and Dusty's granddaughter Anna's wedding providing a snapshot of sociability across families and generations at a single event. Another remarkable event that I experienced – that exemplified the ongoing social interactions between friends and across families over time and generations – was Jada's 70th birthday party.

Jada's house is the hub of family sociability. I came to know all her children, her grandchildren and many of her friends on my numerous visits to her house. However, arriving at her birthday party and finding the house brimming over with over 50 people (most of whom were her 'family') was overwhelming. There were her husband, her eight birth children and their families, her two fostered Jamaican children and their families, their Jamaican father and his English wife, her sister

with her Italian husband and their son and his family, various friends, including some members from the Windrush Club and her fictive sister Dolcemina who had returned from her retirement in Jamaica specially for Jada's birthday celebration. On the whole, there were four generations of people at the event who had been mixing socially for over 50 years. People moved among each other with ease and familiarity, while some gave speeches and sang songs in celebration of Jada's birthday. Also remarkable was the variety of cuisine present – British, Italian, Polish and Caribbean. This event reflected the strong alliance that is possible between individuals as a result of social interactions over time, despite various ethnic origins and social sanctions.

### *Sunday dinners*

Although the many family events and get-togethers gave me some insights into family dynamics and forms of relatedness, it was at open-door Sunday dinners that I was most consistently able to observe sociability in action. This is because Sunday dinners are weekly events for most families. Therefore, in this context, I could supplement my observations with the family histories I was told, for a deeper understanding of the continuities and changes that were occurring within the current family practices.

The frequency of social contacts among family members always depends on geographical propinquity. For members who are more geographically scattered, contacts are less frequent and family get-togethers are often planned around birthdays, holidays and summer picnics. However, almost all the families with members living nearby come together at least weekly, usually on Sundays for socialising and eating food. As with Gobi's family in Chapter 4, although Sunday dinner – lunches or teas for some – was an element of family life during most people's childhoods, among their current extended families, the practice has continued, albeit with modifications made in order to accommodate individuals' lifestyles, family size and other family obligations. Hence, in contrast to the past practices of families coming together at the same time and sharing food at the same table (i.e. commensality), the practice has now taken a more flexible and individualistic approach. Although members converge in a home as a family, the formal aspect of sitting down and eating food at the same time has been removed and replaced with a more laid back approach, whereby individuals come at various times that suit them, help themselves to food – often finding available space to eat with a tray on lap – and leaving at their convenience. The family reminiscences and sharing of weekly events that occurred around the table in the past now take place among individuals meandering between little groups from room to room. Additionally, in contrast

to past stories of children having to behave and often being 'bored' at the dinner tables, sociability has become such that the children now segregate from the adults and play among themselves in a more relaxed fashion.

Family size has contributed largely to the new approach to Sunday dinners. As the family expands, for many, it becomes no longer possible to meet at 'Mum's' or 'Nan's' house, and now negotiations and adaptations are constantly being made to accommodate not only for family size, but also family obligations between different strands of the extended family. Raleigh's parents migrated from the Caribbean in the mid-1950s, and they had ten children. Although his mother Clare is 'not very religious', she took the children to church almost every Sunday and, after-church Sunday dinner has always been a tradition in their home. When I met the family, the Sunday dinner was still being practised but, due to the growth in family size and Clare's advanced age, the event had been modified to accommodate the now large number of individuals. Instead of Sunday dinner at Clare's house, the event now rotates between four homes. One week it is held at Clare's house, another week it is held at Raleigh and his wife Rose's house and the next two weeks it takes place between two of Raleigh's sisters' houses. These are the people with the largest amount of living space. Thus, on any given Sunday, one might find between 25 and 35 individuals at the event.

Another modification, due to family size, was in the food provision. Instead of Clare preparing the entire meal as she did in the past, everyone now contributes to the provision and preparation of food. Contribution to food provision is a common feature across my research families, the result of growing family size. Modifications are also made in the kinds of foods that are cooked and consumed in order to accommodate different palates (see Goode et al. 2003). To begin with, many first-generation migrant Caribbean people have continued to cook largely Caribbean cuisines. Those who have partnered with white British people have taught their partners to cook Caribbean foods and, among the second generation, we find the first migrants teaching their daughters-in-law to cook Caribbean food.

Although the migrants' children have largely maintained a preference for Caribbean foods, they have also adopted other national cuisines – such as British, Italian, Indian, Chinese and so on – often combining elements from them into new, distinctive creations. As with other forms of cultural modifications, such food practice could be perceived as a form of creolisation, a practice that has also been occurring in the Caribbean for centuries. As we move into the third generation, this shift to include a wider variety of cuisines has become even more evident. Thus, at Sunday dinners, while there may be various Caribbean

foods such as rice and peas, ackee and salt fish, curried and browned meats, fried plantains and dumplings, one will also find cabbage and mayonnaise salad, various pasta dishes, mashed potatoes and English bakes and puddings, as well as combinations of them thereof in interesting distinctive dishes – and this, whatever the social class of the families (for contrasting view see James 1997). Sunday dinners thus provide one of the most vivid settings for observing family sociability and for understanding the continuities, modifications and changes that occur in families as a consequence of mixing between groups, as well as a means towards the effective functioning of the extended family. It is here, too, that the degree of family cohesiveness – and the extent to which family relatedness continues after breaches – may be deduced.

### Summary and conclusions

This chapter has traced the emergence and growth of mixed sociability experienced by the mixed African-Caribbean and white British families in my research from the 1950s until 2003. One of the crucial factors in this development appears to have been their school experiences. According to my interviewees, at secondary school it was not from other students but from their teachers that they most often experienced discrimination. Furthermore, by secondary school, the Caribbean migrants' children and their white British peers had come to share what some termed a 'common culture' in terms of language, music and leisure activities, to the extent that many of them were able to discern and reject the discrimination and negative views in society – and for some, within their own families.

These accounts correspond with Back's (1996) findings in his study conducted in the mid- to late 1980s at a youth club in South London. Here, Back found a complex relationship of 'inclusion and harmony juxtaposed with differentiation, exclusion and racism' (Back 1996: 98). However, despite these complex and ambiguous relationships, Back also found that a 'syncretic' (or what I would term 'creolised') working-class youth culture has also developed that was 'neither black nor white but somehow a celebration of shared experiences' (ibid.: 98). This 'syncretic' youth culture, according to Back, 'constitutes a volatile working-class ethnicity that draws on a rich mixture of South London, African American and Caribbean cultural symbols' (ibid.). Back makes particular reference to the transatlantic connections of music cultures of South London – Caribbean, North American and South Asian. Furthermore, as with my interviewees, Back found that despite the prevalence of racism in the locality, on the whole, 'young people did not passively reproduce the ideologies of their parents. In the adolescent community, an inclusive localism

is formulated where it is wrong to exclude people on the basis of colour' (ibid.). Thus, despite racial prejudice, with increased mixing over time, individuals have come together in friendships and intimate relationships, often resulting in complex forms of family relatedness.

Additionally, within some contexts/spaces of social interactions between African-Caribbeans and white British individuals, the chapter illustrates some of the different understandings individuals have regarding the nature of their relationships. Some people have shared understanding about 'neighbourliness' and friendships, and share in spontaneous and reciprocal relationships (Mauss 1954). Others do not share a similar degree of mutual understanding, and relationships become more formal as in relationships between 'guests and hosts' (Benson 1981; Patterson 1965). Shared or unshared understandings between individuals in a context of mixed sociability depend on a number of variables including the nature of interracial contact, the period of time over which relationships are maintained, the history of the relationships and the attitudes individuals hold towards such relationships. These factors could determine whether or not racism is reproduced in a context of multi-ethnic and multicultural existence.

The chapter also shows that in a context of mixed sociability, black and white identity 'is defined as a reaction to racism but also as the creative, process of self-reconstruction' (Back 1996: 146). This was particularly evident during the 1980s and 1990s among the young black and white adults who had grown up together in the same neighbourhoods and attended the same schools. While some of their white parents continued to hold racist ideologies, and some of their black parents continued to segregate themselves, these young adults were able to formulate their own notions of identities or social selves, while abandoning or 'vacating' public notions of identity (ibid.: 240).

Also evident are the different innovations and experimentations that are necessary in a mixed ethnic and cultural context in order to accommodate difference. An example may be found in Jada's family, whereby family practices are worked through in innovative and experimental ways, in order to accommodate ten children and three parents of different ethnicities. A second example comes from Pam's Welsh home economics schoolteacher, who incorporated different foods in her class in order to accommodate the children from diverse ethnic origins.

Finally, with regards to family life, because of growing extended family size, cultural differences, family expectations and obligations, family practices are constantly being adjusted and transformed in order to accommodate family members and achieve a reasonable functioning of the kinship network. One such example is the modification of custom at Sunday dinners. Contrary to the predominant emphasis of James (1997) on class, my research shows that food cannot only be

analysed in terms of social class, but also in terms of history, social relationships, ethnicity and cultural transformations. By contrast, Goode and her colleagues (2003) found in the Italian-American community where they researched, that food content was a matter of varied individual and family choice and negotiation. This seems much closer to the processes which I observed among the mixed-heritage London families. For members in these families, 'menu negotiations' take into account many factors including ethnicity, history, age/generations, diversity of individuals, lifestyles, family size and individual preferences. Thus, as with other aspects of their lives, cuisine also has experienced a form of transformation that can be seen as a process of creolisation.



## 7 Mixed heritage, racial prejudice and social positioning

Chapter 6 has mapped out the growth of mixed sociability experienced by the families in the research set from the 1950s to 2003. We have seen how, despite public and often personally experienced racial prejudice, individuals have come together in friendships and intimate relationships, for some resulting in the formation of mixed families. We have also seen how over time, with increased mixing and cultural exchanges, the children and grandchildren of the African-Caribbean migrants and their white British counterparts have come to share similar interests. Given this evidence, how has the rise in mixed sociability in London in the past 50 years influenced the experience of racial prejudice of individuals in these mixed-heritage families? This chapter aims to address this question, while exploring the strategies family members have used to counteract prejudice through the generations. Additionally, it examines mixed-heritage individuals' understanding of their social positions within their families and the wider society, as well as their agency in constructing and establishing their positions in British society. Thus, it reconsiders Benson's suggestion that, 'for the mixed-race child...there were problems inevitably arising from an ambiguous ethnicity' (Benson 1981: 134). First, however, I take a look at the concept of racism itself.

### **'Racism': Real or imagined?**

Racism becomes an everyday life and 'normal' way of seeing. Its banality and invisibility is such that it is quite likely that there may be entirely 'politically correct' white individuals who have a deeply racist perception of the world. It is entirely possible to look at racism at the level of ideology, politics and institutions... yet possess a great quantity of common sense racism... Outside the area which is considered to be 'political' or workplace...this same white activist (feminist or solidarity worker) probably associates mainly or solely with white middle class people. That fine line which divides pleasure and comfort from politics is

constituted with the desire of being with ‘people like us’.  
(Bannerji 1987: 11)

This quote echoes the experiences of many Londoners, yet the debate over racism as an ideological construct versus racism as material reality continues among social scientists. American race relations literature, as well as the experience of the apartheid system in South Africa and the rise of Nazism in Germany, strongly influenced the race relations analysis in a number of other societies. This included Britain, where the field of race studies was established during the 1940s and 1950s (Solomos 1993: 16). First coined by the American anthropologist Ruth Benedict, ‘racism’ was defined as ‘the dogma that one ethnic group is condemned by nature to congenital inferiority and another group is destined to congenital superiority’ (Benedict 1943: 97). For Benedict, racism referred to ideas that defined ‘ethnic and racial groups on the basis of claims about biological nature and inherent superiority and ability’ (Solomos 1993: 17) – Nineteenth-century ideas about race and progress.

In Britain, early attempts to theorise race and racism were dominated by two central themes.

First, the patterns of immigration and incorporation into the labour market of black and other ethnic communities. Second, the role of colonial history in determining popular conceptions of colour, race and ethnicity in European societies. (Solomos 1993: 18)

During the 1950s and 1960s, a number of early studies under the new ‘race relations’ rubric were carried out, with the main focus being on interaction between the ‘immigrant’ and the ‘host’ communities in employment, housing and other social contexts, but little theorising about racism (see Banton 1955, 1960; Glass 1961; Patterson 1965).

By the late 1960s, the theorisation of race and racism picked up steam when social reforms were put into action in the aftermath of the Civil Rights Movement, urban violence and unrest, and the emergence of Black Power ideologies and forms of cultural nationalism that helped to reshape ‘race’ politics in the US and other parts of the world. In Britain, social transformations around the issues of race that emerged during this decade focused on issues of migration and settlement (see Back & Solomos 2000; Solomos 2003; Goulbourne 1998). Banton’s *Race Relations* (1967) and Rex’s *Race Relations in Sociological Theory* ([1970] 1983) illustrate the trend in research and debate since the 1960s. Banton employed a global and historical approach to compare ‘race relations’ in Britain with societies in the Americas and South Africa. He focused on the situations that arise from cultural contact, attitudes to the concept of ‘race’ and the social relationships individuals

construct on the basis of “racial” categories’ (Solomos 1993: 18; Banton 1967).

For Rex, the study of race relations was concerned with situations whereby the existence of certain ‘structural conditions’ interacted with, and influenced actors’ definitions in ways that ‘produce a racially structured social reality’ (Solomos & Back 2000: 5). Some of these conditions included ‘conflict over scarce resources’,

harsh class exploitation, strict legal inter-group distinctions and occupational segregation... cultural diversity and limited group interaction, and migrant labour as an under-class fulfilling stigmatised roles in a metropolitan setting’). In other words, ‘race is utilized in everyday discourse as a basis for social action. (ibid.)

In effect, it produces differences that carry unequal access to certain ‘goods’.

Both Banton’s and Rex’s works were later critiqued by Miles (1989), who opposed the existence of a sociology of race, arguing that the concept of race – and the very noticing of skin colour – had become collectively shared and disseminated as popular ideologies, partly because of the long history of Western cultures’ elaboration, articulation and application of these ideas – a ‘conceptual inflation’ (Miles 1989: 41-68). For Miles, ‘race’ is an ideological construct that disguises the real economic relationships in society, lacking any theoretical basis for analysis. Hence, from a Marxist position, Miles takes the object of analysis from ‘race’ to ‘racism’, insisting that ‘racial differentiations are always created in the context of class differentiation’ (Solomos & Back 2000: 8). However, as Solomos and Back point out, one danger of Miles’ position is that ‘it can result in a kind of class reductionism that ultimately limits the scope of theoretical work on conceptualizing racism and racialised social relations’ (ibid.). This point is of particular importance to the individuals in the mixed-heritage families in my research. For among them, not only ‘working-class’ but also ‘middle-class’ and ‘professional’ individuals have been victims of racism.

Miles has made a major contribution to the scholarly debate on ‘race relations’ by shifting the analysis from ‘race’ to ‘racism’. His definition of racism as an ideology and the arguments he sets forth in support of his definition are very convincing, especially in ‘his insistence that “races” are created within the context of political and social regulation. Thus, “race” is above all a political construct’ (Solomos & Back 2000: 8). Additionally, and very significantly, another great contribution by Miles is his claim that racism articulates with the ideologies of sexism and nationalism and is historically specific. However, with his focus on class and capitalism (both of which are social processes), he ignores the

mental processes that might sustain ideology. He is less clear on how ideology might articulate with and influence political and economic conditions, or how stereotypes can serve social functions and sustain oppressive power relations. By focusing on truth and falsity, Miles neglects the actuality of ideological practice. As Lichtenberg (1998: 48) notes:

Even if we were to agree that all racism is 'in the head,' however, overtly racist attitudes and beliefs do not exhaust its content. Less-than-conscious attitudes and belief still play an important part in our mindsets. And even if individually such attitudes seem insignificant, collectively they add up to pervasive habits of behaviour that can bring injustice to a whole group of people.

These are material, real concerns that, when addressed more closely, do not support Miles' argument that racism is a 'false' explanation and representation of social processes/actions.

In North America, a number of social scientists (see Lichtenberg 1998; Omi & Winant 1986; Ng 1993; Sniderman & Piazza 1993) have shown the interrelationship between politics, power and racism – the material reality of racism – and would counter Miles' argument by stressing the notion of 'commonsense' and its usefulness in demonstrating how ideological processes are not merely located in people's minds or in theory.

They are embedded in people's daily practices as the normal ways of doing things; in other words, ideology including racist and sexist ideology, is taken for granted and normalized. (Ng 1993: 57)

Thus ideology is forceful and effective in that it has visible results, particularly for the victims of racist ideologies. This is evident, for example, when a black male driving a fancy car is stopped by a white police officer because the officer, drawing on racial stereotypes, assumes the car is stolen or the black male is a drug dealer.

Finally, ideology can become material – a reality – by fixing individuals into positions within hierarchies (Lichtenberg 1998).

Systems of ideas and practices have been developed over time to justify and support this notion of superiority. These ideas become the premise on which societal norms and values are based, and the practices become the 'normal' ways of doing things. (Ng 1993: 52)

Thus, ideological representations can become embedded in institutions and manifest in a range of actions in everyday life. From this viewpoint, ideology is not just about ideas or beliefs, but concerns the practical conduct and real existence of human beings. For example, in the 1993 British case of the racist murder of the black youth Stephen Lawrence, the trial resulted in the acquittal of five white youths believed to be involved in the murder, partly because of the suspected bungled investigation by the Metropolitan Police Service. For this reason, the inquiry (MacPherson 1999) into the case concluded that the Metropolitan Police Service was affected by a culture of 'institutional racism', particularly in terms of canteen talk and stereotyping of possible offenders, which was propelling most officers into racist practices, as opposed to merely a black sheep minority of individual racists (MacPherson 1999: 20-35). Thus, as Lichenberg (1998) notes, 'racism is not [just] a matter of what's in people's heads but of what happens in the world' (*ibid.*: 43).

In Britain, there have been some important studies since the 1980s exploring the role that ideology and political discourse play in contemporary processes of racialisation (see Gilroy 1987; Back & Solomos 2000; Bulmer & Solomos 1999; Solomos 1993). Essentially, what these current investigators do is not simply to reinstate the previous conceptions of race. Although they share Miles' concern 'to understand the dynamics of racism' (Mason 1999: 20), they do challenge traditional treatments of class in British sociology and reflect significant changes in the wider political and theoretical environment (*ibid.*). Gilroy, for example, argues for the need to view the 'race' concept seriously, because 'the actions of organizations of the urban social movement around "race" may themselves assume symbolic significance' (Gilroy 1987: 236). In effect, the more recent debates offer evidence that supports the notion of racism as material reality. For example, Solomos points to the complexities of racially motivated attacks on black people in Britain. Although far right-wing groups are not always directly involved, the impact that they have on the everyday lives of many black people in the country is very clear. The widespread nature of these attacks as well as everyday forms of racial harassment have been confirmed by a number of surveys by the Home Office, the Commission for Racial Equality and local authorities (Solomos 1993: 191).

These more contemporary authors argue that we need to 'avoid uniform and homogeneous conceptualizations of racism' (Solomos & Back 2000: 20). They point to the 'new racism' or 'cultural racism' in contemporary Britain within the political culture and in everyday life. This is evident in the policies and attitudes towards immigrants, refugees and asylum seekers and, above all, on the focus on the perceived threat to 'British culture' from Islam. The focus is increasingly on 'the mythic

“British/English way of life” in the face of challenges posed by the incursion of “foreign influences”. Thus highlighted is the ‘need to situate racism and ideas about race as changing and historically situated’ (ibid.). From this perspective, Solomos and Back rightly point out that the question of whether or not race is an ‘ontologically valid concept’ is irrelevant. What is more important to understand is ‘why certain racialised subjectivities become a feature of social relations at particular points in time and in particular geographical spaces’ (ibid.). This is certainly a question that is relevant for individuals in my study: what roles have racist ideologies played in people’s everyday lives and personal relationships?

From her research carried out in Brixton between 1955 and early 1958, *Dark Strangers: A Study of West Indians in London* (1965), Patterson argued that ‘xenophobia’ (i.e. an intense fear or dislike of foreigners or strangers), did not properly describe British attitudes to outsiders.

The term’s derivation stresses an element of fear and implies a consequent aggressiveness that do not seem dominant in the contemporary British attitude, strong as it is. ‘There’s a foreigner. Let’s heave a brick at him’, is no longer the general reaction in Britain. (Patterson 1965: 207-208)

Instead, Patterson argues that ‘xenophygia’ – flight from strangers – might be a more precise term, as it stresses ‘aversion to and avoidance of outsiders’. Hence, the general reaction, ‘There’s a foreigner. Let’s keep our distance,’ which does not relate only to people outside of the UK, but are also characteristic of relationships within the society – for example, between the English and the Scots, the Northern and Southern English, between counties, villages, boroughs and even streets – still operates among the residents in Brixton (ibid.: 208). In Patterson’s view, the situation in Brixton was not a ‘colour or racial situation’, but an ‘immigrant-host situation, in which the newcomers’ visibility serves mainly to draw attention to the problems inevitably found in the early years of immigrant absorption’ (Patterson 1965: 9-10). In effect, what Patterson has done is deny the presence of racism in British society.

However, in light of the evidence of other studies conducted around the same period as Patterson’s (see Chapter 1), as well as the accounts of individuals in my London research, I would argue that both xenophobia and xenophygia describe British attitudes towards the West Indian migrants. For while some British people did keep their distance, for example, by not letting accommodation to the Caribbeans (see Chapter 3) or moving away when Caribbean neighbours moved into their

neighbourhoods (see Chapter 5) – that is, xenophygia – some West Indians did indeed get bricks (and knives, and bottles) thrown at them – that is, xenophobia. The 1958 riots could be argued as evidence of xenophobia in British society at the time. As Glass (1961) points out, the summer 1958 riots in London took place beyond the fringes of the ‘coloured settlements’ – unlike the Nottingham riots of that same year that occurred in an area densely settled by ‘coloured people’ – and ‘the worst offenders were from housing estates and districts that were almost wholly white’ (Glass 1961: 133).

As in Nottingham, the large-scale disturbances in London, too, were preceded by a series of apparently sporadic assaults on coloured people. But in London it was not the retaliation of a few coloured men which sparked off the crowd outbursts, nor was there a definite chain of incidents during the turbulent days. ‘Nigger-hunting’ simply spread and collected an increasing number of partisans – active forces and passive spectators – simultaneously in several districts. Although no one was killed, the actual violence, and even more the cumulative threats of violence, produced an atmosphere of menace and fear which closely resembled that of a text-book race riot. (ibid.: 134)

As we move from the 1950s and 1960s into the next decades, Patterson’s argument holds even less strength. From her research in 1973 on Jamaican Migrants in London, the anthropologist Foner concluded that: ‘It is the racial stereotypes that most English people believe in and the discrimination that blacks must constantly face that make blackness a stigma in England’ (Foner 1979: 42). Based on beliefs that were still being reinforced by the media, by government actions and by ‘respected public figures’ during the 1970s, Foner states that ‘racial distinctions are built into British cultural definitions, and those who hold unfavorable views about black people are normal rather than exceptional’ (ibid.: 42 citing Lawrence 1974: 198; see also Lowenthal 1972: 224). Given these conclusions, it is not surprising that there was an ‘aversion to intermarriage or miscegenation among a large section of the British population’ (Patterson 1965: 248; see also Banton 1955, 1959; Hill 1965).

As part of a large survey in three different areas of North London exploring colour prejudice in Britain in the early 1960s, Hill (1965) investigated 36 cases of ‘racially mixed’ marriages in London. In 1961, Reverend Hill stated in a broadcast talk on BBC Caribbean Service on Commonwealth Day that, ‘Provided they were in other ways, compatible, I would be happy for my daughter to marry a coloured man’ (Hill 1965: 218). His statement was published by the British Press, and

provoked seven days of 'mostly foul and abusive' correspondence through his letterbox. Among these were the following:

Your statement in a newspaper that you would not mind your daughter marrying a black man seems to me so indicative of the low social conditions in England at present that I feel I must expostulate. Even horses, cattle, dogs, and cats are mated and bred to be of pure race. How much more should man 'made in God's image' be strict in preserving our white heritage! Why lay the possible onus and curse on your child of breeding mongrels and half-castes and bastard children; a race of unhappy creatures who have ignored God's and Nature's rules...You ought to take it as your duty to try to improve the level of life in England not to visualise a half-caste breed, who in such cases always take the worst in each other – so England's disaster would be complete... (an Englishman resident in Switzerland)

Interbreeding is evil and nobody could be proud of half-caste children. You've got a decent English heritage yourself, why plan to encourage your poor little lassie to breed children everyone is ashamed of? The idea of everyone being a wretched khaki colour with thick lips and flat noses in the future is abhorrent to all right-thinking Englishmen... All men are not born equal. There are centuries of evolution behind the whites and you cannot expect the blacks to attain in a few years an equality which isn't there (a Manchester woman).

We can integrate fellow Europeans, the Irish and even certain oriental races who have light skins, or 'European type' features. But God chose to make the Negroes very distinctive so that they cannot be integrated. It is not for you to tamper with God's handiwork! (A Middlesex man). (ibid.: 218-220)

The hostile correspondence led a week later to an attack on Hill's house, with slogans such as 'NIGGER LOVER' and 'RACE-MIXING PRIEST' painted over his doors and windows. Although there were some letters of support, Hill's survey in North London revealed that 91 per cent of the population disapproved of mixed marriages between 'white' and 'coloured' people (Hill 1965: 209). Individuals among the local white population who had no objection to working with 'coloured people' or having them as neighbours, also expressed strong disapproval of mixed marriages (ibid.: 209).

Since these early investigations, although there has been no in-depth research specifically on mixed white and African-Caribbean families in Britain, some insights into changing public attitudes may be gleaned from the British Social Attitudes Surveys (BSAS) and surveys carried



out by other institutes on ethnic minorities in Britain. For example, the Policy Studies Institute (PSI 1997) surveys reported that the percentage of white people who thought most white people would mind if another white person married a non-white person fell from 75 per cent in 1983 to 33 per cent in 1996 (Madood 1997: 314-318). A more recent survey at the Institute for Public Policy Research (IPPR, commissioned by Alibhai-Brown 2001) supported the latest BSA report, and also showed that, while 33 per cent of whites thought that most people in Britain would mind if one of their close relatives married an African-Caribbean, 74 per cent said that they themselves would not mind (Alibhai-Brown 2001: 83). The PSI survey also reported that 84 per cent of African-Caribbeans said that they would not mind a close relative marrying a white person, while 15 per cent said that they would mind (mostly 35-49 year olds). In both the PSI and the IPPR surveys, there was an age factor, with older people minding more than younger. Overall, the surveys showed that currently in Britain, South Asians are the most disapproving of mixed marriages.

While quantitative data can provide useful indicators of changes in social attitudes, with regards to sensitive issues they can also be unreliable – as people may avoid responses that may offend. Hence, with regards to emotive issues such as those dealt with in this book, it is often through more in-depth qualitative inquiry that more reliable information might be gained. That said, by using the survey data as a point of departure, what have been the experiences of the people in the mixed African-Caribbean and white British families in this research? And how have they changed over time? As we shall see, negative attitudes to mixed families have been reduced, but have not totally disappeared.

### Early families

The case of the Smith family in Chapter 3 provides a good example of a mixed family who suffered from the attitudes similar to those described above during the 1950s and 1960s. But while this particular family's experience of racism within the wider society was severe, their families of origin nevertheless embraced their union. However, most of these earlier families were not as fortunate as the Smiths. For the majority of them, hostility came not only from the wider society but also from individuals within their extended families.

To begin with, because of the social atmosphere during this period, many couples did not go out together in public so as to avoid becoming visible targets of racism. Merna recalled having to 'run for our lives' from a group of white youths in West London as she and her Caribbean partner walked home one evening in the late 1960s. On their

wedding day, Dawn and Dusty Smith went separately to and from the church in North London to avoid racist abuse. Furthermore, because the wives were predominantly white British women, they suffered the most. They became visible targets for racist verbal abuse when out with their children, primarily from white people shouting out things like 'Nigger lover', 'black man's whore' and 'Have you got a monkey in the pram?' In Jada's family, no one was spared the experience of racism. While she suffered verbal abuse, her children were victimised at the local school (Jada raised ten children: her eight 'white' children and her two 'black' foster children). The white teachers told Jada that her 'black' children were 'hopeless' in the classroom: 'These chappies are great on the sports field and therefore weren't worth the effort'. Meanwhile her 'white' children were taunted by peers who called their mother a 'tart' who must be 'sleeping with a black man'. Many white wives also experienced strong disapproval and ostracism from members in their families of origin. Over time, however, through a combination of increased interactions in families and in public places, and through the birth of children, some family members began to change their attitudes.

### **The 1970s and 1980s**

The 1970s were a period of pause with less public racism. There was less new Caribbean immigration and no public outbursts such as the 1958 riots. On the other hand, for some individuals, disapproval from their white families of origin persisted. The 1980s saw a further and, in some ways, surprising change. While, on the one hand, disapproval by fellow family members had lessened and some relatives reconciled, on the other hand, the drop in public racist expressions of the 1970s was reversed in the 1980s. During this period, public hostility came not only from the white community – including increased discrimination from the police – but also from the African-Caribbean community. After having experienced a less hostile phase during the previous decade, couples and families had gained enough confidence to venture out in public together, but the social climate of the 1980s incited a resurgence of hostility towards mixed relationships and marriages. While hostility from the black community came primarily in the form of 'unpleasant stares' and disapproving comments, physical abuse came mainly from the white community. Merna, who, in the late 1960s, had to 'run for our lives' while she was out with her African-Caribbean partner, had remained in West London where she grew up. During the 1970s, life seemed 'calm', but one evening in 1981 while walking home with her partner, they were 'badly beaten up' by a group of five 'skin-heads' who used broken bottles and sticks. The couple had to be

hospitalised. Due to this 'traumatic experience', they left the area and moved to a more 'mixed' area in West London.

Not everyone could move away so easily, due both to a lack of economic resources and the housing shortage. Karen, a white Englishwoman, was one such individual. In varying degrees, Karen and her family endured eleven years of 'suffering' at the hands of her 'white racist' neighbours in her South London home. She has been with her African-Caribbean partner since the mid-1960s and had also experienced racism during that period. In the 1970s, the couple moved to South-East London to raise their family. While she ignored the racist taunts during the 1970s, by the 1980s, the situation changed to violence. Here is her story:

When I first had my daughter we lived in South-East London [in the 1970s], and when I used to push her in the pram, this particular family, which was a staunch National Front family used to give me leaflets which said, 'Have you got a monkey in the pram?' and stuff like that to me, because she was mixed race. And so I used to ignore this type of thing, and really not give them any credence at all. And then as my children got older, the taunts went on in different ways.

When my oldest son was then sixteen [in the mid-1980s], I'd gone out with a friend, just to go down and get some milk, and it was on our way back that this particular family started to say abusive things to us. So my friend said, 'Let's go and speak to their mother about this'. So that's what we did, and that was probably our first mistake, 'cause as we went to knock on the door, there was more abuse shouted [at us]. So as we turned away, they threw a really heavy piece of equipment at my friend's head, which was cut, and one at my back – which resulted in us both being in hospital.

And that just resulted in, really, weeks of torment from this family. And even though we knew the family who did it, because we couldn't say, 'Yes, this particular one threw this, this particular one', the police didn't do anything about it. And I was in fear. My daughter was only about eight or nine at the time, and she used to walk home from school with my other son, and I used to worry that they would be waiting for her down the end of the road while I was at work. So it was awful! And they'd come and knock on the door, banging on the door, trying to get us out of the house. So that was pretty hideous, actually. That wasn't a very pleasant experience. It was a council house I was in, so they moved us here [South London] in 1989.

The lack of police intervention was a common experience for many families who suffered abuse. On the other hand, police harassment was also a common experience. This harassment appears to have intensified during the 1980s. White women especially reported being constantly stopped by the police, *only* when they were with their partners or other 'black people'. How might the rise in public hostility towards mixed African-Caribbean and white families during the 1980s be explained? Moreover, why was there hostility now from the African-Caribbean community?

The 1980s were a period of social and political unrest in British society, and London, in particular, experienced its share. The unemployment crisis that had begun in the late 1970s intensified with the new Thatcherite government, such that by the end of 1982, Britain had experienced its highest unemployment rate ever (Marwick 2003: 228; Rosen 2003). This resulted in especially high levels of unemployment for migrants who performed unskilled jobs in declining industries. While many South Asians turned to self-employment – mainly to small enterprises such as newspaper shops and neighbourhood groceries from limited initial investment (Rosen 2003: 93-94) – the economic recession appeared to have weighed most heavily on 'black youth' (Marwick 2003: 230). From a combination of unemployment and its resulting frustration as well as intensive policing – some argue provocation/harassment on the part of the police – in black communities (*ibid.*; see also, Phillips & Phillips 1999: 351-366; Hiro 1991: 81-96; Solomos 1993: 147-158), a series of riots erupted in Britain between April 1980 and 1985. In London, the riots began in April 1981 in Brixton, culminating in 1985 in Tottenham.

Unlike the 1958 riots, the 1980s riots were 'not between races, but between groups of mainly young blacks and the police' (Hiro 1991: 81). Both black and white youths participated in the rioting and looting (*ibid.*: 86; Solomos 1993: 154). White participation was also explained in terms of unemployment and deprivation in the inner cities. On the whole, the factors that emerged as dominant causes of the 1980s riots 'in popular opinion were an amalgam of poor social conditions and police misbehaviour' (Hiro 1991: 91; see also Solomos 1993: 154-158).

If the urban unrest of the 1980s was not primarily related to 'race', how then might the white hostility towards individuals in mixed families be explained? One possible explanation is that earlier attitudes of whites towards African-Caribbeans might have been re-ignited among racist individuals (such as skinheads and members of the National Front, who attacked Karen's family) by the reporting of the riots. For although these were not really race riots, 'a quarter of the population, predominantly white, held blacks responsible for the troubles' (Hiro 1991: 92).

With regard to emerging black hostility towards individuals in mixed relationships during the 1980s, it appears a key factor was the rising influence of revolutionary 'black consciousness' among second-generation African-Caribbeans. Unlike the situation in the 1958 riots whereby the newly arrived migrants were intimidated by white racists, by the 1980s, their children had become young adults, and had begun, since the 1970s, to assert their place in British society. Although the Black Power Movement that began with the Civil Rights struggle in the US in the 1960s had some impact on the migrants at the time, visits to Britain by prominent Civil Rights and Black Power activists such as Martin Luther King, Stokeley Carmichael and Malcolm X most effectively raised the consciousness of the Caribbean community as a whole. It was during this period that 'blackness' and 'being black' became an idea that Caribbeans felt could define them and reconnect them to their African roots (Phillips & Phillips 1999: 231-236). Hence, in 1970, the Black Panther Movement and the Black Unity and Freedom Party were set up in London, with branches in other parts of the country. These groups advocated Pan-Africanism and African liberation, calling too, for radical change along class and racial lines in Britain and the rest of the world (Goulbourne 1998: 65).

Thus, it might be argued that this new sense of 'Black Pride', black solidarity and self-affirmation influenced disapproval of mixed marriages and mixed families by members from the Caribbean community. Some African-Caribbean women in my study spoke of disapproval they experienced from African-Caribbean men in the form of comments such as 'Sell out' or 'You are diluting your race/community/culture'. Some white women experienced verbal abuse from African-Caribbean women such as 'Have someone of your own'. From such standpoints, for African-Caribbeans to form mixed relationships with white people was seen as a rejection of Black Pride. Likewise, as some of my African-Caribbean peers have told me, they see mixed marriages and mixed families as an action of 'lightening up' by 'marrying up'. It is deemed a sharp contradiction to the efforts of the Black Power Movement of eradicating the internalised negative legacies from slavery and colonialism that exist among 'black people' (see Fanon 1963; 1967). Nevertheless, despite the increased hostility during the 1980s and the efforts of black radicals, mixed relationships resulting in mixed families continued to increase in London – ironically, many of the black radicals formed mixed families themselves. However, as we shall see, prejudice against these families continues today.

## Mixed families today

### *Racism within families*

As we move into the contemporary context, there appears to be a decrease in the experience of racism and disapproval within the wider family. Chapters 3, 4 and 5 illustrate examples of families where disapproval existed but, with increased association over time, acceptance and close relationships have developed between individuals. While some parents are not too keen on the idea of intermarriage for their children, the birth of grandchildren has continued to be a major factor contributing to family acceptance. In the 1980s, when Jenny married her English husband, her Trinidadian mother and her brother disapproved to the extent of severing all contact with her for nine years, on the grounds that she was 'sullyng the family blood'. When Jenny's first child was nine years old, she decided to reconcile with her mother, but their relationship could only begin to be rebuilt after her brother – whom, according to Jenny, is her mother's favourite child – had a child with an Englishwoman. Jenny's mother has since become a very active grandmother to this child.

For some families, relationships appear smooth on the surface, and only from individual conversations may apprehension or disapproval be detected. Effectively, what disapproving individuals have done is strategically suspend their opinions – at least within the family – for the sake of running the family network harmoniously. Becky and Rodney's family provides a good example. Both Becky's African-Caribbean mother Willa and Rodney's English mother Patsy expressed apprehension about becoming members of a mixed-heritage family. Willa was introduced earlier in Chapter 6 as someone who, in 1961, had been hospitalised from an attack by two white males. Hence, her apprehension as a member of a 'mixed-race' family had been informed by her earlier experience. From observations, however, it is difficult to detect any anxiety in Willa. She relates well with her son-in-law, has regular contacts with Becky and Rodney and their daughter and, on the Sundays when Rodney works and can't attend dinner, Willa sends food home for him by Becky.

Becky has no knowledge about her mother's anxiety. On the contrary, she believes that her marriage is 'not an issue' for her mother. Willa, on the other hand, told me that although she has reservations about mixed marriages, 'my motto is that if a man takes care of your daughter and he cares for her, you have nothing to say but good things. She is happy, and no mother can ask for more than that. He is like my son really'.

Rodney's mother Patsy is also apprehensive about his marriage to Becky. Contact between Patsy and her son's family is quite frequent

and she is fairly active as a grandmother to their child. However, while Rodney believes that his mother is 'delighted' about their family – based on her behaviour – and Becky sees her relationship with Patsy as 'very close', Patsy paints a more ambivalent picture:

I'm very glad they [Rodney and Becky] have come together, but having the baby, that worries me. I am not very happy being a grandmother to a mixed-race child. No, I don't agree with it. For Rodney and Becky I have no problem but, generally speaking, I don't agree with the mixture. I don't want everybody being brown. I think people should keep their identity. I think it's very, very important, actually. Maybe there'll be no problems, because things are easing up so much, but... I personally don't think it's an ideal situation. You don't want to lose cultures, you know! No, I think it's very important that people keep their culture. I think people should mix socially... In some ways, that's why we don't get a lot of trouble in this road. We are so mixed we are not a ghetto. I think you need to mix, but I'm not sure about intermarriage, I'm really not.

Despite her ambivalence, Patsy provides regular childcare for her grandchild. Additionally, she introduces Becky as her 'daughter' and maintains that she has a closer relationship with her than with one of her own daughters who is an 'alcoholic' and an 'irresponsible mother'. Effectively, what the two mothers have done is to find ways of suspending their own apprehensions regarding mixed families and to adapt to the choices made by their children – for the sake of maintaining family connectedness. As Patsy points out, 'it's his [Rodney's] choice. I'm not married to her [Becky], and I wouldn't risk losing my child over his partner'. Hence, as in other aspects of family relatedness, here we find the women investing tremendous effort in doing kinship, even at the expense of their own beliefs.

Finally, with regards to experiences of racism within families where strong disapproval remains – without any willingness on the part of the disapproving individuals to adapt – parents devise means of protecting their children from the experience of racism. Mary (a white Englishwoman), for example, has been very familiar with racism in her family since she first met her African-Caribbean partner Jessie in the 1960s. However, over time, her maternal family changed their views and accepted Jessie and their children, but her paternal relatives remained estranged. Her paternal grandfather died years after her children were born, and was never told of his grandchildren. It was when her grandmother became ill that she was told of her grandchildren. Apparently, Mary's relatives kept the knowledge from both grandparents

because 'they thought it would kill them'. Before her grandmother died, she requested to see Mary's children, but Mary declined her wish because, as she put it, 'I felt that her racism was too entrenched, and I wanted to spare them the possible look on her face'. Though, when her grandmother died in 2001, she took her sons to her funeral. Although in Mary's case there was no reconciliation with her paternal family, her strategy of avoidance was devised as a means of protecting or, as she put it, 'sparing' her children from racism. According to her: 'there is enough out there that they will have to contend with as mixed-race boys who will be treated as black in our society, so they don't need to experience it in their family also'.

### *The wider society*

As in the 1980s, in the current environment, these mixed families have continued to experience racism from individuals in the wider society, from both blacks and whites. On a number of occasions in public places, I observed racism towards members of the families in my research, ranging from disapproving stares to unkind comments. However, one particular event stood out as a prime example of how little some people's attitudes have changed towards mixed-heritage families.

Petra, a second-generation African-Caribbean woman lives with her English partner and their three children in East London. On a Thursday morning in August, I went to visit Petra and her children. As it was a nice sunny day and the children were off on summer holidays, she seized the opportunity of my company to help take the children on a day outing. We decided to go to Greenwich. There, we strolled around the market for a while looking at the different stalls and then sat on the patio of a nearby pub for lunch. Petra's youngest child, who was twenty months at the time, was sitting in her stroller. At the table next to ours was a couple I assumed (based on their spoken accent) to be English, and the woman started a conversation with Petra, seemingly admiring the baby in the stroller: 'Oh, how old is the lil' 'un?' she asked Petra. 'Twenty months,' replied Petra. 'Oh, I bet she speaks different languages because of her dad,' said the woman. 'No, she only speaks one: English. Why?' Petra replied. The tone of the conversation changed instantly, as the woman began to express her opinion about 'mixed marriages'. 'Oh, I don't agree with all these mixed marriages and children being born this colour, and half that, and half the other...' Petra responded: 'You know what lady, that is your opinion, and you are very much entitled to it, but what makes you think my children and I would like to hear it.' The situation became somewhat uncomfortable, and Petra and I asked for containers to pack the rest of our food, and we



went to the park where we finished our lunch with the children. On the way to the park, Petra told me that it was because of such experiences that she feels it important to educate her children about race: 'That woman was fine until she found out that my child was half-white. Any other race would have been fine, but not her race, God forbid! What is the problem with these people?'

Such a public display of racism, although it still happens, is not the most typical contemporary experience. One couple described two incidents of physical abuse in public: one in 1989 when a white male was struck by a black male as he and his partner walked holding hands in East London; the other was in 2000 when they were attacked by a black male in a market in West London. More common are disapproving stares and unpleasant comments from both blacks and whites. Furthermore, among the current generation, it is primarily when people venture outside their neighbourhoods that they experience racism. In sum, although experiences of racism for individuals in mixed families have continued through the generations, for most of them, the intensity of incidents has lessened, reflecting the changing political and social climate. At the same time, the strategies that individuals use to cope with racism have also changed.

### **Dealing with racism**

Among the earlier families, because of the hostile social attitudes towards African-Caribbeans and mixed marriages at the time, a strategy of avoidance was taken to cope with racism. One strategy for couples was to avoid being seen together in public. Because of the general lack of social support during the earlier years, when racism was encountered in neighbourhoods or in the general public it was largely ignored by the victims. The Smith family endured all forms of racism, from having human excrement thrown on their front door to having swastika graffiti and 'Get out you Black bastards' written in black all over their front door. The family's reaction, according to Dawn, was simply to 'wash it off! What else could you do?' Similarly, when women encountered racist comments while out with their children, they usually ignored them.

The older African-Caribbean men also spoke of their strategies for coping with racism. Dusty Smith, despite the neighbours' reaction to his family, felt that if 'I behave myself as how I see people are behaving around me, then, eventually, people would change their attitudes'. Thus, by not playing loud music and keeping his surroundings tidy, he was 'fitting in like a jigsaw puzzle'. By the 1970s, Dusty was indeed 'respected' by his neighbours. The men in his local pub who refused to serve him or drink with him in the 1950s and 1960s later came

knocking on his door for him to join them. Humour was another tactic some of these older men used to cope with racism. Owen, for example, laughed at the 'absurdity' of his workmate who thought he came from a tree like monkeys, before proceeding to educate him on such matters.

For most of these earlier families, their main strategy for dealing with social racism was to socialise with others like themselves. According to Fred: 'We all stayed in our own little world, 'cause it's safe, it's familiar, and you want to be with people you can relate to'. This applied to family as well as to friends. Karen (a white Englishwoman), for example, once heard her best friend's husband, whom she had also been friends with for many years, say: 'If my daughter went out with a black man I'd put her in her coffin'. Karen, who at the time had a 'black' partner, left immediately and has not socialised with those friends since.

The experience of public racism still continues though different in intensity and in kind. Despite the resurgence of racist experiences in the 1980s, individuals among the families today have since become more active in dealing with racism than those from the earlier families. Since the 1960s, public housing policy and also individual initiative have resulted in a much wider geographical dispersal of Caribbean migrants so that more live in mixed neighbourhoods, thus increasing the likelihood of social mixing. Secondly, successive Race Relations Acts (1965-1976) have legally banned racial discrimination in public places, in housing and in employment, thus affording more social rights to Caribbean migrants and their children (Goulbourne 1998: 101-103). Thirdly, the 1981 disturbances in London resulted in a situation whereby migrants could finally have their voices heard by local and national governments (*ibid.*: 66). Given these developments, not only do individuals in the current generation of families have more choices in terms of housing, areas to live, schools to send their children and places of leisure, but they have also become more empowered – partly due to their own agency – and less willing to be passive recipients of racism. Thus, as individuals and as families, they have devised several strategies as means of counteracting racism, which enables them a more comfortable existence than the generations before them.

### *Neighbourhoods and schools*

To begin with, due to the growth in mixed neighbourhoods in London, families now have a wider selection of tolerant places to raise their families than did the earlier families. The majority of them have consciously chosen to live in mixed areas. Of the couples and their children in this study, all except one live in ethnically mixed areas. We saw earlier how, after two racist incidents, Merna moved from the West London area where she grew up to a more ethnically mixed area. A

white Englishwoman named Lucy, who said she grew up in a 'very small British middle-class community and didn't know anything else about anybody else in any part of the world' also said that, after travelling as a young adult, she 'realised that there was a world of different cultures and people besides what I knew'. When she married her first English husband, she decided to raise her family in an area of London with 'mixed cultures', and she encouraged her children to 'mix'. Her daughter Magda conveys the views of many families in the current generation. According to her, growing up in an ethnically diverse area is a 'natural thing, that's all I know'. Magda, who has an African-Caribbean partner and a child herself, 'cannot imagine living anywhere that is predominantly white. I feel he [her son] needs to be able to mix socially with people from all cultural backgrounds, 'cause I don't want him to grow up with a narrow mind'. Adam, another man who grew up in a small Welsh community, feels that raising his 'mixed race children in a white neighbourhood where they never see another black face would be irresponsible'.

Rose, a white Englishwoman who grew up in East London in the 1960s, was used to having Caribbean neighbours and friends at her school. After marrying her African-Caribbean husband, she remained in East London to raise her family. In the 1980s when the council was demolishing her estate, they decided to re-house her family in a new housing association scheme. When she went to the council office to choose a home, they told her, 'You can't have one of those houses because they're for Asians and minority groups'. However, when Rose, who said she 'wasn't buying any of that racial thing' – meaning she didn't want to be segregated from non-white families – told them that her family was part of a 'minority group', she was given her choice of home. Rose's situation illustrates how, even in the current context, individuals in mixed families still have to struggle against institutional racism in order to create the life they wish for their families.

The one family who chose to live in a predominantly white area illustrates the unease that this decision can bring. Alice and Buster, who are both school teachers, bought their house in 2002 from a work colleague in South London. After moving in, they realised that, except for the occasional 'three or four black persons' on the high street, Alice was the only non-white person in their immediate neighbourhood. Their neighbours on the right were very welcoming, but the neighbours on their left were, according to Buster, 'not very friendly'. After about six months these neighbours moved away, having lived in their home for over 30 years. They told Buster – though he never asked – that the reason they moved had 'nothing to do with neighbours'. When Alice and Buster recounted the incident to the friend from whom they bought the house, however, they were told, 'Oh they have strong views when it comes to

black and white and that sort of thing'. Buster and Alice remained with their family, and a Jamaican family moved into the vacated house. They now feel more comfortable because they now have good relationships with their neighbours on both sides.

Some families are motivated to live in ethnically diverse areas also because of the ethnic diversity among the children in the schools. This strategy of choosing ethnically mixed areas in which to live and send their children to school is a way of counteracting racism, and has proved very effective for many. On the whole, it is in these areas that the least racism is experienced among recently settled families.

### *Places of leisure*

Families are also selective of the places they choose for leisure and social activities. Thus, they talked about going to places that cater to a diverse mix of people. Fortunately, most clubs and places of leisure in London no longer discriminate as they did in the past. However, some people spoke of feeling uncomfortable when they visit relatives living in small towns and villages outside of London, because some of the local white people look strangely at them. For some, it is the behaviour of some service people in some small towns towards their black family members that they find uncomfortable: two people spoke of being ignored by white bartenders. It is for such reasons that Sid only visits his family in the small English town where he grew up out of 'a sense of duty'.

Similarly, as a tactic for avoiding becoming targets of racism, some couples avoid overt display of affection in public. Having had two racial attacks in the past five years while they were holding hands in public, Carla and Joseph have since avoided any form of physical contact in public. With Pearl and Bert, although they have never had any racist experience as a couple, she avoids expressing affection in public because she is conscious of the disapproving looks she receives – especially from 'black men' – and is concerned for Bert's safety.

### *Friends*

Participants in my research also socialised with people who are similarly in mixed relationships or mixed families and individuals who are accepting of their situations. These are people with whom they can share common experiences, common interests and common political views. Some individuals lost their adolescent friends once they became involved in mixed relationships. Jenny, an African-Caribbean woman, lost some of her childhood friends when she married her English husband, because she refused to respond to their battery of questions:

'What are you doing with a white man, girl?' 'Can't you find a black brother?' Jenny has remained friends with one woman who disapproves of her family situation, but her strategy is to socialise with her alone and avoid any mention of her husband. Some white individuals sever their friendships with other whites because they cannot accept their constant stereotypical comments and racist jokes.

### *Challenging racism*

Unlike individuals in the pioneering families who were largely intimidated and who ignored or walked away from racism, among current families today – and even now some of those earlier pioneers – individuals will more often than not challenge the racism they encounter. By confronting racism, they feel that they are educating others and facilitating an end to the perpetuation of racism. As Lorna put it, they are saying to people: 'We deserve to exist in this society the same as you without your hostility and intimidation'. In effect, as individuals who have come together from different cultural and ethnic origins to form family units, through modes of resistance to racism, they are asserting their sense of belonging in British society.

We were introduced earlier to Petra as she confronted the woman in Greenwich who expressed her views about 'mixed marriages' and children born of such marriages. I was also with Gloria and her family one Saturday afternoon in Kew Gardens when she responded to what she felt was a racist incident. As we sat having tea, one of her sons called out, 'Mummy! Mummy!' A little white girl sitting next to us turned to her mother and asked: 'How can that be his mummy? He is black and she is white!' Her parents began to giggle, and Gloria turned to them and asked, 'Are you going to explain to your daughter they [her sons] got a black dad and a white mummy, that's why they are brown children?' Without replying, the family left. Karen, who has had her own past share of racist encounters as a white member of a mixed family, continues to experience racism as she plays with her grandchildren in her neighbourhood park. She recalled the time a white mother turned to another white mother and said: 'It's the children I feel sorry for'. Karen turned to her and said: 'My children have a lot of love. What is it you think they don't have?'

Katrina's neighbours went a bit too far with their expressions of racism. Katrina, a white woman, lives with her second-generation Caribbean partner and their three children in South London. In 1999, after being repeatedly taunted by her neighbours, she woke one morning to find sprayed all over her door 'Katrina stinks of nigger'. She knocked on the neighbours' door, and the mother came out and tried to argue with her. Katrina 'dragged' the woman outside, 'beat her up and

threw her inside her house' and left. She then reported the incident of the painted door and her reaction to the police. The case was dealt with by Katrina's family getting relocated by the council. There were other stories of individuals challenging people in public who made unkind comments about them, especially when couples were out together. Even Dawn, the white woman married to a Jamaican man (see Chapter 3) who in the 1950s to the 1970s 'ignored' racist encounters, now challenges them. She finds her views constantly being challenged by neighbours of her own age (for example, on the local bus), disapproving of 'mixed-race people'. The conversations never get far, however, as Dawn soon tells them that their views are also directed at her, and she has spent too many years having to cope with their racism.

Some parents spoke of challenging racism in their children's school. One remarkable story is that of Merna, a white Englishwoman, herself a schoolteacher, who said she is familiar with racism even at an institutional level. She showed me a letter (dated from 2000) that was the consequence of her reaction to her son's reports of racism at school. Although Merna and her children live in an ethnically diverse neighbourhood, most of the white and non-white children attend the local Catholic school. Her older son Julius attends a different school and is one of two mixed-heritage students in his year. After several incidents of racial bullying, Julius told his mother who, in turn, went to the head teacher to complain. The head's reaction was that 'children will always pick on other children's *weaknesses* [her emphasis]'. To this Merna replied, 'My son's colour is not a *weakness*. How dare you!' The head apologised and Merna demanded action. The head acted by sending a newsletter to the homes of all the children stating: 'We can't dictate to you what you do at home, but we will not put up with any racism in our school'.

Some people reported being 'shocked and surprised' when they experienced racism from friends. Cathy (a white Englishwoman), was 'shocked' when an old family friend whom she knew from Oxford, 'a well-educated, and well-cultured woman', asked her shortly after her daughter married a Barbadian: 'When is some good news going to come out of your house?' Cathy replied, 'My daughter has married the man she loves. Aren't we all entitled to do that? The fact that he is black is irrelevant!' According to Cathy, leaving Oxford for London has 'opened up' her mind, and 'I pity people who still hold those views'.

### *Dealing with racism within families*

Finding strategies for dealing with racism within families proved most challenging. Unlike the above situations in which individuals feel justified in confronting racism, partly because of the knowledge that there

are public policies in place to defend them (for example, under the Race Relations Act), there are no policies in place for racial discrimination in the private sphere. On the whole, as one man named Barry pointed out, 'people carry on badly in every family' – and racism may be considered an aspect of this. We have seen how some family relationships dissolve because of racist attitudes. When this happens without an attempt at reconciliation, it is usually because, as a strategy, parents try to shield their children from racism. Conversely, when some parents become aware of racism within their families, they confront the individuals with those views, and try to reach some compromise whereby they may coexist as relatives, without their attitudes being revealed to the children.

With some individuals, there are contradictions between the specific experience of belonging to a mixed-heritage family and their general attitude towards such mixing. Patsy says she has 'no problem' with her son's marriage to his African-Caribbean wife and, from my observations, she relates well to her daughter-in-law and is an active grandmother to their child. Yet, she also said that she 'disagrees with inter-marriage' and 'little brown babies'. Jenny's Caribbean mother ostracised Jenny and her family for nine years because she disapproved of her marriage to an Englishman, but has subsequently become an active grandmother to her son's child by an Englishwoman. These women have effectively made adaptations for the sake of relating to their children and grandchildren.

### **Educating children about 'race'**

Finally, because of the challenges these families face, some parents feel it necessary to educate their children about 'race' as another strategy for coping with racism. Those who do so say that, although their children are 'mixed', due to the pervasiveness of racism in British society, being 'part white' will not defend against racism directed at blacks, because society ignores the white part of them. Essentially, by educating their children about 'race', they try to instil in their children a positive self-identification in a society that might try to negate this.

There is an interesting difference in the approach the African-Caribbean and white British parents in my research use in educating their children about race. While, in the main, the African-Caribbean parents educate from a historical and political stance, based on their awareness of the various socio-cultural constructions of colour, the white British parents educate from a more individual position. For example, Richard, a second-generation Jamaican, teaches his sons that, although they are 'mixed-race', society will see them as 'black' because,

historically and politically, that has always been the case. Richard tells his sons:

People are going to see a black boy when you go to find a job, when you walk down the street, when you get stopped by the police. Therefore, while I want you to feel comfortable about where you belong and how you identify yourself, you also need to know the history of black people in this country.

On the other hand, Merna, as an Englishwoman, teaches her sons that they should embrace their 'dual-heritage'. She says to them:

Never see your colour as a weakness. If someone is going to look at you certain ways because of the colour of your skin, that's their problem. Don't try hard because of your colour. Try hard for you, because you want to succeed in life.

The difference between these two parents' approach might be explained in terms of the historical experience of racism. Racism for African-Caribbeans in Britain has been an ongoing *experience*, so that their attitudes are informed by their experience. For many whites, racism remains something that is *observed* and, only after becoming part of a mixed family, have some white individuals experienced the impact of racism (see Rosenblatt et. al. 1995; Lichtenberg 1998).

Some parents feel that there is no need to educate their children about race. Their rationale is that, although they realise that racism pervades the society, they believe that raising the issue might prove counterproductive. Hence, they rely on their children to focus on the positive racial attitudes they encounter from family and friends. However, other researchers have suggested that, in order for mixed-heritage children to develop a positive self-identification, discussions about 'race' produced more positive outcomes in the long run (see Wilson 1981; Tizard & Phoenix 1993, 2002). My observations and the narratives told by mixed-parentage adults and children support this view. I was visiting Petra one afternoon when her nine-year-old son Junior came home from school, complaining of bullying from another pupil who called him a 'half-chat monkey'. When Junior wanted to know what the term meant, the explanation turned into a half-hour discussion that culminated with educating his younger sister about differences in skin colour, using coloured crayons and a notebook to illustrate different shades of brown. This scene demonstrated the emerging awareness of the socio-cultural construction of colour in London, even among the very young.



This basic lesson in understanding racism and colour distinctions in a context of mixed sociability was missed by Verna and her siblings Kate and Jude (see Chapter 5) in their upbringing. Growing up in their village community in the Midlands in the 1980s, these siblings felt that they 'didn't fit in because it was full of white people'. In their schools, they were called 'Blackistani' by their white peers and were 'always made to feel different'. This was during the height of the Black Pride renaissance and, according to Jude, 'while white people were treating me different 'cause I'm not white, black people were treating me different 'cause I'm not black'. In retrospect, they felt that, had their parents been less 'neutral' and educated them about the importance of skin colour in this society, they might have been more equipped to cope with the hostility they experienced. Thus, although Verna and her sister Kate believe that 'race' has become less of an issue for their children in the current context of 'multicultural' London, they do respond to their children's queries regarding race in a manner they believe will help their children learn about the issues from historical and political perspectives.

Essentially, by educating their children about racism, parents are informing them about the history of their kinship. This is done in the historical and political context of Britain, in general, and of London, in particular, thus instilling in their children a sense of belonging as citizens within their society. Moreover, although parents feel that their children should be aware of racism and how people might treat them based on the colour of their skin, they believe that it is also important for them to embrace their dual-heritage (see also Caballero et al. 2008). Collectively, these strategies for coping with racism over time and generations have been instrumental in facilitating the *positive* identification and sense of belonging among the children in these mixed African-Caribbean and white British families. This has been another significant change that occurred between the earlier families and the contemporary ones. This final section of this chapter partly illustrates how this change came about.

### **Locating the self in the context of mixed sociability**

The presence of racially mixed persons defies the social order predicated upon race, blurs racial and ethnic group boundaries, and challenges generally accepted proscriptions and prescriptions regarding inter-group relations. Furthermore, and perhaps most threatening, the existence of racially mixed persons challenges long-held notions about the biological, moral, and social meaning of race...

The increasing presence of multiracial people necessitates that we as a nation ask ourselves questions about our identity: Who are we? How do we see ourselves? Who are we in relation to one another? ...Resolving the identity crisis may force us to re-examine our construction of race and the hierarchical social order it supports. (Root 2004: 143)

This extract by Root refers to the 'biracial baby boom' in the US that began about 30 years ago, after the laws against miscegenation were repealed in the state of Virginia in 1967. However, in the British situation, too, the same questions might be asked: 'Who are we? How do we see ourselves? Who are we in relation to one another?' But before exploring these issues among the research families, let me make a note on ethnic identity.

As with the concepts of race and racism, ethnicity is a contested concept. Is ethnicity something stable that is essential or fundamentally given or guaranteed in the distinctions between groups of people – 'primordial bonds' or attachments (Geertz 1973: 255-310 cited in Jenkins 1999: 89), or is ethnicity fluid whereby, through 'self-ascription', individuals or groups choose to shift or alter their ethnic identification depending on the circumstances (Barth 1969: 14 cited in Jenkins 1999: 89)? The debate among earlier scholars was never quite clearly defined, as both positions overlapped in many ways. Geertz, for example, recognised that 'The general strength of such primordial bonds, and the types of them that are important, differ from person to person, from society to society, and from time to time' (Geertz 1973: 259 cited in Jenkins 1999: 89). For his part, Barth, while rejecting the idea that ethnic groups are definable by some cumulative inventory of cultural traits that their members share, recognised the power and stability that may be inherent in ethnic identifications: the 'organizing and canalizing effects of ethnic distinctions' (Barth 1969: 38, 10 cited in Jenkins 1999: 90).

Whereas the earlier generation of anthropologists and other social scientists viewed ethnicity as cultural reproductions, more recent scholars have taken a more holistic approach. They now look at culture, history and politics, as significant factors in social relations that influence individual or group identities (see Cohen 1996; Hall 1996a, 1996b). As Hall (1996a: 4) notes:

Identities are never unified and, in late modern times, increasingly fragmented and fractured. Never singular but multiply constructed across different, often intersecting and antagonistic, discourses, practices and positions. They are subject to a radical

historicization, and are constantly in the process of change and transformation.

Thus Hall (*ibid.*) suggests:

We need to situate the debates about identity within all those historically specific developments and practices which have disturbed the relatively 'settled' character of many populations and cultures, above all in relation to the processes of globalization', [which Hall argued] are coterminous with modernity, and the processes of forced and 'free' migration which have become a global phenomenon of the so-called 'post-colonial' world.

It is within this framework that the 'new ethnicities' identified by some recent scholars may be analysed (see Back 1996; Hall 1996b). 'New ethnicities' that account for '*difference* and diversity' (Hall 1996b: 161-163) – both culturally and subjectively – and that are situationally defined, may be strategically or tactically manipulated, capable of change at both the individual and collective levels (Jenkins 1999: 89). It is also within this framework that the new ethnicity among the mixed-heritage individuals in my London research finds relevance. For, as I will show, their ethnicity is 'not an essentialist, but a strategic and positional one' (Hall 1996a: 3). Along with other kinship processes, their ethnicity may be viewed as a form of creole ethnicity. Because as with other processes of creolisation, their 'mixed' ethnicity developed through a process of becoming, through innovative strategies over time and in their local context.

### **'Mixed-race' children and new ethnicities**

The psychological adjustment of 'mixed-race' children has been a popular area of concern in the US and in Britain. The popular view had been that neither the black nor the white community accepts children born from mixed marriages and they therefore develop identity problems because of their ambiguous social positions (see Gordon 1964; Benson 1981). Thirty-nine years ago (1970-1971), Benson conducted research on mixed couple families in London. Based on reports from parents about their children's 'identity' and from incidents Benson witnessed herself, she concluded that many of the children had 'identity problems' (Benson 1981: 143). 'For the mixed-race child... there were problems inevitably arising from an ambiguous ethnicity' (*ibid.*: 134), and more than a third of the 'mixed-race' children 'were reported by their parents to have problems related to their ethnic identity, which typically took

the form of attempts to deny or negate the fact of their colour' (ibid.: 142), and to 'define themselves as white' (ibid.: 141).

Benson's work had special credibility – because she was of mixed heritage herself – but as we shall see, her argument was almost certainly mistaken for a number of reasons. First, with a sample of 27 children ranging from a few months to over twenty years old – without any indication of the ratio of older to younger children – the reliability of her conclusions are questionable. Secondly, and I believe most importantly, her conclusions regarding their 'identity' were not based on the children's own accounts, but on the anxieties of their parents and upon her own impressionistic observations. Therefore, one could argue that her evidence was scanty and without sound empirical basis (Wilson 1987: 16). Thirdly, her result could reflect the social-political time when her research was conducted for, indeed, there was some time lapse before subsequent studies reporting 'positive identity' among 'mixed-race' children (see Wilson 1981; Tizard & Phoenix 1993, 2002; Caballero 2007; Caballero et al. 2008). However, this argument is not totally plausible, as a contemporary to Benson also reported positive identification among 'mixed-race' British children (see Durojaiye 1970).

The 34 mixed-heritage families from my London research whom I came to know, included 29 adult children of mixed heritage over the age of twenty and 43 between the ages of one-and-a-half and nineteen. Of those who were born between 1950 and the early 1960s (contemporaries of those in Benson's research), only one person, Lolly, reported having problems with her ethnic identity. Lolly was born in the early 1960s to an English mother and a Barbadian father. When she was eight her mother had a stroke and the family moved to a town in a neighbouring county away from London to be near her mother's sister for help and support. Although Lolly lived in this town for just two years, to her, it felt like 'ten', and these years remained the strongest in her memory because they were 'just horrible'. As the only 'black' child in her school and in their neighbourhood, she was 'constantly being called names for being black'. Thus, because of the racism, she wanted to be 'white' so she wouldn't look different. After two years of hostile experience, the family moved back to an ethnically mixed area in London, and Lolly began to feel 'comfortable' again with her skin colour. Unlike Lolly, the rest of the children from that period reported having 'no problem' with their skin colour.

For example, Polly (born 1950) and her brother Mark (born 1951), grew up in a neighbourhood in North London where there were no other children like themselves, and where their family experienced harsh racism (see Chapter 3). However, their experiences of growing up in what Polly calls a 'multicultural home' with many people from various ethnic backgrounds influenced their positive self-image. She said:

I never thought or wished I wasn't mixed. I just accepted it, because I had this happy upbringing in a multicultural home where I could mix with people. And the people in the house always validated me and always used to say, 'Oh, you're so pretty. When you grow up you're gonna be lovely'.

In her brother Mark's words, 'I never thought of myself as a black person or a white person, I just thought of myself as a person. I have a white mother and a black father. Everybody had a mother and a father, it just happened one was white and one was black in my family'.

Of the children born after the 1960s, there were only two, Verna (born late 1969) and her brother Jude (born 1979) (see Chapter 5), who, like Lolly, felt uncomfortable with their skin colour. Verna and her siblings grew up in a predominantly white neighbourhood in the Midlands. They, too, experienced racism from the community. Verna recalled that she 'wanted to be white, because I lived in a white area'. For her brother Jude, being the only 'black kid' in his school where the teachers and his peers treated him 'differently', his desire was to be neither 'black nor white, but to get the hell out of there', because 'I just knew that I didn't fit in'. However, as I will show, self-identification is fluid and changeable, being influenced by the socio-political changes in society over time.

The accounts of 'ambiguous identity' by Lolly, Verna and Jude point to the lack of open discussions of racial issues in their families as being a strategy to counteract racism. None of their parents educated their children on issues of 'race', and for these children, their experiences of ambiguity regarding their skin colour were more intense when they lived in predominantly white areas. In contrast, among the other children of that period, issues of 'race' were regularly discussed in their families. Additionally, it appears that living in a segregated neighbourhood might encourage feelings of ambiguities, since these individuals all lived in white neighbourhoods.

The construction of identity is a complex process. As Hall points out: 'Identity is always a question about producing in the future an account of the past, that is to say it is always about narrative, the stories which cultures tell themselves about who they are and where they come from' (ibid.: 1991: 5). While 'race' is one element that individuals will explore in constructing their cultural identities, other factors such as nationality, ethnicity, gender and class are also significant. As James (1999: 39) states: 'These factors change over time with individual's changing awareness of self, others, and the social system, through interactions and in response to social change'. For children of mixed African-Caribbean and white British parentage, 'black and white are both

elements in their racial identity, which can be played up or down according to context' (Wilson 1987: 36).

Thus, we find, for example, Lolly and Verna positioning themselves differently at different times, in order to adapt to the changing contexts within which they find themselves through the decades. Up until the 1990s, Lolly felt as though she was 'floating on a little island in the middle of the Atlantic, because I'm neither English nor Bajan [Barbadian], I'm just on that island'. As we saw earlier, when she lived in the town outside London she wanted to be 'white' because everyone around her was white. When her family moved back to London in the late 1970s she felt more comfortable as a mixed-heritage individual. However, by the 1980s when the Black Pride movement picked up steam in Britain, she wanted to be 'black'. This period was also a 'difficult' period for Lolly because, depending on where she was and with whom she was speaking, she found herself grappling with 'racial' and national identification. While in England she felt 'embarrassed to say I'm English to a white person' and, because of comments from whites such as 'You're alright for a black person' – which she felt were 'denial of my white English heritage by white people' – she was inclined to see herself as 'black'. On the other hand, saying 'I'm English to a black person' meant that she was 'ashamed of' and 'denying' her Caribbean background. However, on visits to Barbados, she felt that calling herself Barbadian 'was a joke' to the locals who positioned her as 'an Englishwoman'. Additionally, forming intimate relationships with 'black men' during the 1980s and early 1990s posed a challenge for her, because she felt that she was 'not black enough for them. I've been brought up too English, and haven't got the black culture'. Lolly has a son with an Englishman, and thinks the situation has become 'a lot easier for kids nowadays'. A judgment she makes based on her own observation is as follows:

I think more people are mixed now, which is a good thing, because if you've got someone in your family of colour, then you're unlikely to be racist. If you love someone, a grandchild or whatever, then maybe your tolerance could influence the people around you.

Lolly feels no longer that she is 'floating' on an island and, according to her, 'now I actually love being me. I love my skin colour, very happy with it'. Moreover, she identifies herself as a 'mixed African-Caribbean and white British person'. Her teenage son identifies himself as a 'mixed-race British' person.

Verna's perception of herself also changed in parallel with the social and political changes in Britain during the last few decades. As with

Lolly, during the 1970s and early 1980s when Verna lived in a predominantly white neighbourhood, her experience of racism made her wish she were 'white' so she could 'fit in'. As a young adult in the mid-1980s, she moved to Wolverhampton where she came into contact with more African-Caribbeans and, from her account, she 'became a militant black then'. At the time, 'Wolverhampton was very, very black and proud, and in fact, I tried to deny I even had a white mother to some people. I was slightly embarrassed, because I wanted to belong. I struggled and suffered for it'. Since moving to London in the early 1990s, she has come to embrace her dual heritage and, according to her, 'I am who I am now. Now I am really happy being mixed, and I feel at my most comfortable living in London'.

Lolly's and Verna's situations illustrate how individuals' sense of identity – who we are, and where we come from – may be internalised during primary socialisation when externally imposed categorizations become major contributors to ethnicity (Jenkins 1996: 91). However, whether through external categorisations or self-ascriptions, perceptions of the self are products of local contexts that undergo continual change over time and under particular social and/or political circumstances (Hall 1990, 1991; Jenkins 1996; Wallman 1983).

Since Benson conducted her research, many public developments have encouraged a more positive sense of belonging and self-esteem among blacks and people of mixed parentage in Britain. Because most neighbourhoods are less ethnically segregated, there has been increased social contact between Caribbeans and whites and, to some extent, an 'increasing liberalization of white attitudes', which may 'reduce the stigma attached to being black or of mixed parentage' (Tizard & Phoenix 1993: 3). Additionally, the influence of Black Power has helped to empower mixed-parentage individuals, but they have reinterpreted Black Power ideas to fit their own experiences. Thus, as Tizard and Phoenix (1993) point out from their study, 'a sizeable proportion of young people reject, or are unaware of, the view' that they should see themselves as black, just because 'the rise of the black consciousness movement led to a renewed insistence on the "one drop of black blood makes a person black" rule' (ibid. 3). I have found similar attitudes among young people of mixed parentage in my London research families. Thus, Olive, born 1958 of an English mother and a Trinidadian father, rejects the notion of the 'one drop rule', on the basis that she had no experience of racism growing up, and was raised primarily by her white mother. According to her:

If I say that I'm black, then I deny the fact that I've got a white mother, and I won't do that because, at the end of the day, my biological father left us, and my mother was the one who looked

after us. So why should I deny her that? If I was going to deny any part of me, it would be him. It is obvious that I am mixed.

Polly's experiences in her home environment also informed her positive self-identification and self-esteem. What the Black Pride Movement contributed was pride in her 'frizzy hair' and more 'black clubs' for dancing, where she could dance with the expressiveness that she knew from her family, instead of feeling like 'a square peg in a round hole' while dancing to the Beatles and the Rolling Stones at her all-white school dances. Thus, on the one hand, the influence of Black Pride has helped Polly feel positive about her own physical appearance but, on the other hand, it has not led her to deny her white ancestry.

The data from my London research suggest that, in the current climate, children in London born of mixed African-Caribbean and white British parentage do not feel torn between the black and the white communities. And although identity is not always a matter of *total* free choice, individuals do have a *certain amount of choice* about how they define themselves (Wilson 1987). Thus, mixed-parentage individuals in my research families have chosen to construct their own identification categories such as 'brown', 'mixed race', 'mixed heritage', 'mixed parentage', 'African-Caribbean and white', 'mixed Caribbean and English' or 'half West Indian and British', which, for them, have become adequate idioms for locating themselves within the society, thus providing them a *positive* sense of belonging and self-esteem. It is the need for this positive sense of belonging that has impelled some to become active agents in transforming the way in which they had been defined by the state.

Through their struggles and strategic manipulations, they have made a significant step in releasing themselves from the institutional structures of 'racial' categorisation that existed up until the 2001 census and coerced them into what Lolly called a position of 'half-denial [denial of the white side]' through inclusion in the 'Black-Other' category of the 1991 census (see Appendix I). Since then, through their strategies, they have effectively located themselves between their African-Caribbean and white British heritages, thus validating their existence and declaring their visibility in British society.

In 2001, the category for 'Mixed race' with its four sub-groups – 'White and Black Caribbean', 'White and Black African', 'White and Asian' and 'Any other mixed background. Please describe' – was introduced for the first time in official statistics (see Appendix I). Although, in the 1991 census it was estimated that there were 230,000 people of 'Mixed race' in Britain (a figure disputed, with the correct figure being over 290,000), 'the preparation for the 1991 census explicitly rejected a "Mixed" category' (Owen 2004: 245-7; see also Appendix I). Instead, the only option for people of mixed African-Caribbean and white British



parentage was to identify under the 'Black Other' category (see Owen 1996). By contrast, after the 2001 census, the Office for National Statistics reported that more than 677,000 people in the UK described themselves as being of 'mixed ethnicity' (see also Aspinall 2002, 2004, 2008, 2009a, 2009b; Caballero 2007; Caballero et al. 2008; Song 2003, 2007, 2010a). Mixed-heritage people are the third-largest ethnic group in England and Wales; the largest mixed ethnic group is of white and black Caribbean extraction.

The inclusion of the new 'Mixed' category in the 2001 census was partially due to the agency of mixed-heritage individuals in Britain. Many in my London research spoke of the 'frustration' they felt in the past with the ethnic question on census forms and job applications. Many said that they deliberately ignored the 'Black Other' category and drew a line merging the 'White' and 'Black Caribbean', so indicating the 'mix'. Some wrote 'Mixed' on their merged line. Polly conveyed the satisfaction of many like herself, with the new category.

These tick boxes that they try to get you to fill in, luckily now, they have come up with a better category. I've got two job applications on which they've finally put 'Black Caribbean and White'. That's one of the tick boxes on the form. At last somebody's got it right... as opposed to 'Other' or 'Black Caribbean' or 'African', then 'White and Irish' or 'Other'.

Well before they had this box that said 'Black Caribbean and White', I used to tick the Irish box and 'Black-African/Caribbean' box, and then I used to draw a little line to make them merge into one, and I'd write 'Mixed', just to get them to read something for their monitoring purposes... But it seems that it's worked over the years [laughs]... I don't know if it's just in this country they realise, cause there is a high proportion of people that are mixed African-Caribbean and white.

The efforts of Polly and others like herself have indeed been recognised at a national level, as an Office for National Statistics report revealed. Reporting on consultations on the ethnic group question, a number of points were made supporting the need for an explicit 'Mixed' category. 'These included demand from the mixed race population, the growing size of the group, and users' needs' (Owen 2004: 246). The report stated:

The 'mixed group', known from the full census classification and the Labour Force Survey to be one of the largest ethnic groups, is regarded as a strong candidate for inclusion, based on the group's happiness to describe themselves as such and the

increasing numbers in this group are not currently met by identification through free-text responses. (Aspinall 1996: 50 cited in Owen 2004: 246)

Essentially, people of mixed heritage wanted to be able to identify themselves as such. This positive identification with being 'mixed' supports the findings of my research and the more recent study of Tizard and Phoenix ([1993]; 2002) of 'black' and 'white' 'mixed race' adolescents in London, and contrasts with Benson's (1981) suggestions that such individuals experienced ambiguous identities. Nevertheless, mixed-heritage people continue to encounter 'denials' at an institutional level. An example of this is the story Bert (a white Englishman) told me of his son's confusion over the questionnaire he was given at school in 2003 from the Local Education Authority. The questionnaire required students to evaluate their teachers' performance, along with filling out a tick box about their own ethnicities. They were given two choices at the bottom of the form: 'black' and 'white'. Bert's son refused to tick the box because he considers himself 'mixed'. The situation was taken up with the education authority, and an apology was given.

In sum, the mixed African-Caribbean and white British population have, through the ongoing process of mixed sociability, emerged as one of the largest ethnic groups in Britain today. Far from denying any part of their heritage, they have fought and struggled to carve out a place in British society where they can finally be acknowledged for who *they* feel they are. As we have seen, the two older individuals (Lolly born 1961, and Verna born 1969) in my study who reported feeling ambiguities during their childhood and adolescence no longer have those feelings. Polly, at 53, the oldest mixed-parentage individual in my research conveys the sentiments of many like herself in the current environment.

I'm just very, very happy with who I am. I love everything about my identity. I love the mix, I love the Caribbean mix, the Irish mix, everything. I love it all. I'm just so *happy* [her emphasis] to be who I am.

## Summary and conclusions

Given the experiences of individuals in this research, the data suggest that Miles' (1989) notion of racism as an ideological construct is not sufficient for analysis of contemporary lives. As I have shown, although ideological representations might be embedded in people's minds as well as in institutions, they become manifest in practical conduct in the everyday lives of individuals. Furthermore, given the changing face of

racism in Britain in the last 50 years (for example, away from the focus on 'race'/colour to a focus on culture/'cultural racism'), I agree with those scholars who emphasise the need to 'situate racism and ideas about race as changing and historically situated' (Solomos & Back 2000: 20). With this approach, we are better able to understand why certain groups of individuals (racialised or otherwise) become targets in particular geographical contexts and at particular points in history.

Although experiences of racism continue to occur in the present, the data suggest that, by comparison with the earlier situation, for individuals in my research there is significantly less open expression of racism and colour prejudice. This evidence could be related to the emergence of a 'new racism' that has been identified, with the switch in focus being from threats caused by other 'races' to those by 'foreign influences' on the 'British/English way of life' (Solomos & Back 2000:20). Conversely, many second- and third-generation African-Caribbean individuals and their white British contemporaries in this study said they have become 'culturally similar'. This illustrates how, in a particular context, over historical time and through changing social processes, the 'other' (African-Caribbeans versus the Africans or, more recently, Muslims) may become closer to 'us' (white British).

For individuals in these mixed-heritage London families, the typical expression of racism has changed from physical attacks to verbal abuse. Both contributing to, and resulting from, this change is the increased social mixing over time between African-Caribbeans and white British Londoners, both in the city as a whole and within their own families. Neighbourhoods are less segregated. Dance clubs are no longer just 'black clubs' or 'white clubs', but places where people from diverse ethnic groups socialise. From my observations, it appears that the difference in the proportion of individuals from different ethnic groups at any given place of leisure owes more to class and cultural capital than to colour or ethnicity. For example, at Latin, African or Caribbean events, the participants are usually of a more diverse mix than those at a classical concert or at an art gallery (though here it depends on the theme of the exhibition). Additionally, although there were a few reported incidents of physical attack in the last two decades, on the whole, there have been changes for the better in the frequency, intensity and kind of racism in public.

The changes in intensity and kind of racism experienced by people in my research have not only occurred as a result of the socio-political changes in Britain from the 1950s to 2003 (the year I completed the research), but also because family members are often themselves active agents in effecting change. Among the younger generations, an increasing number have become less passive recipients of racial hostility, and have devised strategies to cope with and combat racism. They have

deliberately chosen where to live, to send their children to school and to go for entertainment, usually choosing places where there is a mix of people from diverse ethnic backgrounds. They have also been selective in their choices of friends, by either socialising with people in similar family situations or people who are tolerant of their situations. Additionally, it appears that individuals in contemporary families are more willing than the earlier families to confront racism both within their families and in the wider society.

Finally, as a strategy to protect against racism and to prepare their children for possible racist encounters, most parents now educate their children about race. Their reasons for doing so reflect their awareness of the various sociocultural constructions of colour that still exist in twenty-first century British society, with parallels to such constructs in the Caribbean from the slave period to the present (see Henriques 1968; M. G. Smith 1965; Lowenthal 1972; Hoetink 1985; Alleyne 2002; Moncrieffe 2004). This, too, could be seen as another adaptive strategy and a significant aspect of the creolisation of kinship in the London context. Within some families there are individuals who still hold racist attitudes or are still disapproving of 'mixed-race' families. However, as a strategy for maintaining family connectedness, these individuals suspend their beliefs – usually for the sake of their children and grandchildren – in order to adapt to their family situation.

While it was suggested that, in the past, individuals in mixed relationships, in mixed families and of mixed-parentage had ambiguous identities (Banton 1960; Hill 1965; Benson 1981), over time, with the growth of mixed sociability, this 'problem' appears to have been ameliorated for most individuals. For the children of mixed parentage, in particular, ambiguity seems to have been replaced by a new pride in their mixed heritage. Hence, this research finds common ground with the subsequent conclusions of Wilson (1987), Tizard and Phoenix (1993, 2002), Back (1996) and Caballero and her colleagues (2008). Essentially, as with these studies, my findings suggest that the children of African-Caribbean and white British parents do not want to deny any part of their heritage. Moreover, they have become active agents in creating their own 'mixed' ethnicity in contemporary Britain, as a way of asserting their sense of identity and belonging. In effect, through their own agency, they have brought to fruition what Wilson asserted two decades ago: for children who live in 'multiracial' areas, 'the concept of being mixed race may provide a viable identification in its own right which gives the child a sense of belonging and self-esteem' (Wilson 1987: 36-37).

This emergence of 'mixed' ethnicity in London could be compared to the emergence of 'creole' ethnicity(ies) that emerged in the Caribbean (see Burton 1997; Besson 2003; Hintzen 2002). From the complex

interaction of 'race', class and culture among the Europeans and the African slaves and their descendants, emerged 'Euro-Creole', 'Afro-Creole' and 'meso-Creole' ethnicities in the Caribbean over five centuries (Besson 2003: 171, 1997: 42). The Euro-Creoles are the European settlers (the elites) and their white European descendants, the Afro-Creoles, are the African slaves and their descendants, and the meso-Creoles are the descendants of the Europeans and the Africans through 'miscegenation'. Of particular relevance to the 'mixed' ethnicity among the London families is the 'meso-Creole' ethnicity, which emerged through 'opposition, resistance, miscegenation and creolisation in changing social contexts' (Besson 2003: 171).

As with the meso-Creoles in the Caribbean, the mixed African-Caribbean and white British individuals in London have, through an ongoing process of creolisation, struggled to have their 'mixed' ethnicity acknowledged in a society where individuals are often positioned and treated according to socio-cultural constructions of colour. In the Caribbean, there are structural and cultural ambiguities regarding the meso-Creoles, despite their phenotypically mixed appearance. For although they may be of mixed parentage, whether they are classified by the wider society as 'coloured' or 'black' is determined by their social-class positions. Thus, a middle-class meso-Creole may be phenotypically 'black' or 'coloured' though regarded as structurally and culturally 'coloured' (hence the local saying 'money whitens'). At the same time, a meso-Creole peasant cultivator who is phenotypically 'coloured' is seen by the wider society as structurally 'black' (Besson 2003: 172). However, in her study in West-Central Jamaica, Besson (2003) found that the meso-Creole peasant cultivators regard themselves as 'mixed', and have strategically asserted their ethnicity within capitalist class relations through their focus on family land and strong transnational kinship ties. This provides them with resources to maintain a certain standard of living – reflected in their farms or small plantations and in modern housing purchased, built, improved or rented with earnings from either Jamaica or overseas. (See also Hintzen 2002 for the case of mixed Asian Indian and Afro-Creoles ethnicity in Guyana and Trinidad, called 'Douglarization'). The situation among the mixed-heritage individuals in these London families finds parallels with the meso-Creoles in the Caribbean. As with the meso-Creole peasant cultivators, mixed-heritage individuals in this London research also regard themselves as 'mixed' and have employed different strategies to challenge nationalist constructs and to redefine their racial and national identities.

Finally, the new 'mixed' ethnic identities that these mixed-heritage individuals have constructed in 'multiracial/multicultural' London have implications both for anthropology (and the social sciences in general) and beyond the academy to wider public debates. For anthropology, it

adds depth and range to theoretical debates about structure and agency: the capacity of human beings to strategically and innovatively intervene in their own lives and determine the formation of their social realities (up to a point and with varying degrees of success), in the context in which they live and the social relationships in which they participate. With regards to wider public debates, the construction of a new 'mixed' ethnic category by these individuals points to the need for 'a new cultural politics which engages rather than suppresses *difference*' (Hall 1996b: 162; his emphasis). Thus, 'mixed-race' individuals have *chosen* to be recognised as *visible* and responsible agents whose hopes, desires, opinions, experiences and actions matter in the society in which they live and participate.

## 8 Conclusion

The study of kinship has been of particular interest in the history of anthropology. While African-Caribbeans have been making kinship in Britain for the last half-century, they have not been investigated as part of the fabric of British kinship. Moreover, they have, since their arrival in the 1950s, also been making kinship with their white British counterparts, though these mixed kinship relationships have also gone uninvestigated. What have we learned from my exploration of this ongoing and un-researched aspect of contemporary British kinship from the 34 mixed-heritage African-Caribbean and white families in London?

To begin with, a study of this kind has methodological implications that differ from the traditional anthropological perspective (Chapter 2). While participant observation is crucial to anthropological inquiry, conducting a transgenerational study of this kind was only possible through the combination of historical data, oral narratives, in-depth life story interviews and participant observation. The narratives and personal life stories not only gave me important insights into how individuals interpret their social relationships in the present, but also, importantly, into their past life experiences that have shaped their current lives. They offered me a “window to the past” that allows for the exploring of life courses and events that have already taken place, and therefore no longer can be experienced by the investigator’ (Besson & Olwig 2005: 2). Historical accounts of London since the early Caribbean migrant settlement depict the general context of migrants’ experiences, both at local and institutional levels. However, they offer very limited knowledge of the migrants and their families who are subjected to these structures, their experimentations and innovations in carving out a life for themselves against the constraints they faced. It was through the oral histories that these aspects of their family lives could be understood. Besides the limitation of participant observation alone in conducting transgenerational research, conducting anthropological research in a dense urban centre such as London meant modifications to the traditional method of living with participants and becoming immersed in their daily lives. Thus differing circumstances defined differing methods.

The mixed African-Caribbean and white British families in London have emerged through an ongoing process of social interactions and

relationships over the last 50 years. The roots of these families go back to casual social encounters and interactions in a hostile environment. Moreover, for many African-Caribbeans and individuals in these mixed-heritage families, racism has not been simply an ideological construct that reside in their minds. Their experiences show that the concept indeed has material reality. In parallel with this development, there have been changes in the wider social environment, such that, although racial attitudes still exist, the intensity and the nature of racism have also changed. This points to Back's (1996) assertion that 'there is no one monolithic racism but numerous historically situated racisms' (ibid.: 9). Thus, there is currently a 'new racism' that has been conceptualised both in 'political culture and in everyday life', shifting the focus from 'race' (or the strangers among us who look phenotypically different, as in the earlier decades of Caribbean settlement in Britain) to 'ethnicism and cultural differentiation' – or 'foreign influences'. This 'new racism' poses challenges to the 'British' way of life (Solomos & Back 2000: 20, 22), and could partly explain the changes in the nature of racism experienced by individuals in my research.

However, despite the hostility, some of these social encounters developed into friendships and intimate relationships that led to the formation of mixed families. Indeed, it has been through inter-group contact, especially among the second and third generations of African-Caribbeans and their white peers, that we mainly find a breach in the cycle of racism (see Chapter 6). For although some white parents still held racist ideologies and some black and white parents did not share similar understandings regarding neighbourliness or other forms of behaviour, among their offspring, we find strong friendship alliances with shared interests and ideologies, to the extent that they now feel that they have become 'culturally similar'. Thus Jenny, who, in retrospect, understood her family's disapproving reaction to her white friends and husband on the basis of their hostile experiences in London, as a youth, she felt the need to 'vacate' (Back 1996: 94) a situation she felt was accepting and sustaining racist ideology. She escaped to a place where she was not confronted with racism and where her friends shared similar social and political interests. We also find the migrants' children becoming agents of change in their multiethnic/multicultural spaces. For example, it was due to the resistance of the African-Caribbean students in Pam's home economics class at secondary school that the teacher experimented with different ethnic foods, thereby encouraging mixed sociability between the students.

Among the mixed families themselves, there has been an ongoing dynamic process of modification involving family conflict, rejection, violence, adaptation, accommodation and innovation/creativity in order to survive as families and kindreds. There are many features in their



kinship patterns that are features neither wholly British nor wholly retentions of family forms brought over by first-generation Caribbean migrants. These include patterns of residence, their complex kin relationships within and beyond households, patterns of marriage, parenting and informal child fostering. Other features include the use of kin terms based on personal experience rather than on descent and the inclusion of kin based on the quality of a relationship rather than on blood. Also of significance are continuities of relationships even after endpoints such as separation and divorce, lifelong bonds of three and four generations of blood and non-blood kin, exchange networks linking kin members – locally, nationally and transnationally – the centrality of women and the significance of children (and fathers) in linking kin networks.

In the current London context, these have become innovative developments of kinship, creating a different system that incorporates elements and influences from both cultures. For example, from British sources, these include attitudes to marriage (the much higher proportion of legal marriages than in the West Indies), childrearing (less disciplinary practices), leisure activities (participation in football), housing (council tenancies) or eating patterns (afternoon tea). Other developments appear to be new in terms of both cultures, for example, the active role of men in childrearing in mixed families. Whatever their sources, these mixed forms ultimately belong to the local context in which they have been transformed: adaptive structural features as part of a resilient response to changing social, political and economic conditions. In my view, they are family forms that have developed through a process akin to the process of creolisation.

Creolisation as a concept, although originated in the Caribbean to describe cultural and social processes of resistance and survival, is potentially fruitful in analysing the process of kinship among the London families. Unlike hybridity, which as a concept connotes movement and mixture (usually of biological entities), creolisation also refers to conflict and structural inequalities. So while creolisation is about mobility and mixture, it is also about violence, tension and conflict – ‘a process of *contention*’ (Bolland 2002: 38). Running through the book are many examples of these processes of creolisation. These began with the uprooting of the migrants in the early 1950s and their arrival in a largely inhospitable environment. Of those who did nevertheless form intimate mixed relationships, even after defying society’s disapproval, some were confronted with the disapproval of family members. Thus, from the very beginning, these families found themselves in conflicting webs of social rejection, injustice and inequalities, to which they have had to devise modes of response, which, in effect, become new modes of doing and making kinship. Hence, as with the process of creolisation, their

kinship is a process that is not fixed, but is dynamic, conflictual and complex, constantly undergoing transformations in order to bring meaning and some sense of normalcy to their lives.

Such transformations of kinship include some specific forms of family socialisation and relatedness that are very much akin to Caribbean creole family patterns. It is particularly striking how non-Caribbean white mothers are also instrumental in adapting and transmitting these creole family patterns. So 'traditions' are no longer just survivals maintained by first-generation migrants, but are also replicated, innovated and invented not only by their descendents, but by the white British kin who become their partners.

Regarding forms of marriage, Leach (1961), drawing on his Sinhalese data, showed that because marital institutions may take various forms and serve various functions in different societies and cultures, they should therefore be analysed in a particular social and cultural context. He further demonstrated that different forms of marriage may coexist within the same society. Thus the 'complex' marriage/conjugal system which is elaborated by three types of marriage: "extra-residential" or duolocal visiting relations, "consensual cohabitation" or coresidence, and legal marriage' (Besson 2002a: 283; Barrow 1996), which have been features of creole families for centuries, are also practised by the members in these London families. As with Caribbean creole families, these types of marriages among the London families sometimes coexist, resulting in a dual marriage among some couples. In Chapter 5, for example, we saw Lionel living between Chantal and their children and another woman. Similarly, in another family, Seta, who was legally married to Mary, also maintained a second home with another woman, Cleo, with whom he had two children. Interestingly, although Seta was a responsible 'husband' (to both women) and father to his sons, his wife Mary was unaware of his other home for 25 years. Mary, who herself had no children, later willingly accommodated Seta's sons as members of her family – another creole family adaptation of family inclusiveness that extends beyond blood and is often 'for the sake of the children'.

Other characteristics of the London kinship system that find parallels with Caribbean creole kinship system include the range in household composition: single parent (mother or father), female-headed and extended, sometimes including non-blood relatives, and relationships forged through half-siblingship and 'outside children' (Besson 2002a: 277; Barrow 1996; Alexander 1996). Resulting from these various household forms is the existence of bilateral kinship networks with extensive kinship ties that extend transnationally to the Caribbean and North America and other parts of Europe, with flexible boundaries and kin members offering help and support when needed – also features of Caribbean creole kinship system (see Bauer & Thompson 2004, 2006;

Thompson & Bauer 2000; Besson 2002a, 2002b; Chamberlain 2005, 2006; Horst & Miller 2006; Levitt 2001, 2002; Olwig 2005, 2007).

Bilateral kinship networks have long been recognised as an aspect of Caribbean creole kinship (see Barrow 1996; Clark 1999 [1957]; Besson 2002a; Olwig 1981a; Smith 1988). This bilateral kinship system that recognises an individual's parents, the individual's full and half-siblings, parents' siblings and half-siblings, grandparents, cousins that extend far beyond the first, second or third cousins and sometimes including fictive kin, is not typical of British kinship system (see Firth et. al. 1970; Young & Willmott 1957). Yet, among these London families, it is a basic feature. The lack of in-depth anthropological studies of contemporary urban British kinship makes it difficult to pinpoint with any certainty the continuity of British derivations in these mixed family patterns. I have suggested some instances above. A further confusion is that the tendency of change in British family patterns, for example, towards cohabitation, serial monogamy and children born out of wedlock (see Mansfield 2006) points strongly in the direction of Caribbean creole kinship patterns.

Leach's perspective that marital institutions may take various forms and serve various functions in different societies and cultures can also be usefully applied to the London families in my research. This perspective can show how an individual's conjugal system should be analysed in its own particular social and cultural context, for example, as a product of its London context (a British creation) even though it resonates with Afro-Creole characteristics. To begin with, the degree of social and conjugal mixing between African-Caribbeans and the local white majority is very different, and much greater in London where nearly half of younger African-Caribbean people have white British partners at all social levels. In the Caribbean, by contrast, the white population is a small minority and nearly all elite. Thus, although minor degrees of colour mixing are normal, 'interracial' relationships and marriages among the black majority and the white minority are often among the middle and upper social classes (see Henriques 1968; Smith 1988). Secondly, the collective households consisting of kin and non-kin that we find in early families (African-Caribbeans and mixed families like the Smith family in Chapter 3) and some contemporary families, as in Gobi's family (Chapter 4), are unique to their situation in London. In the Caribbean, such extended kinship arrangements would be found in 'yards' on family land consisting of various houses (see Besson 2002a, 2002b) as opposed to one dwelling. A third feature that is unique to these London families is the manner in which the white British women become carriers of both African-Caribbean and British cultures.

A fourth feature found among the London families that resonates with creole Caribbean families and is worthy of a concluding comment

is child fostering. In the Caribbean, child fostering (sometimes called 'child-shifting' or 'child loaning') is an *informal* practice that is perceived as a domestic 'responsive strategy' (Gordon 1987: 442) to economic and other pragmatic circumstances, whereby a child is relocated from less secure homes to more secure ones, often within the bilateral extended kinship network, but sometimes to homes where the child does not have biological ties (see Barrow 1996; Besson 2002a; Clark 1999 [1957]; Goody 1975; Gordon 1987; Olwig 1981b; and among Afro-American families (Stack 1974)). In Britain, by contrast, the practice of bringing up a child – whether through adoption or fostering – that is not biologically related to a parent usually involves a strict and sometimes difficult legal procedure. Yet, in the London context, the practice is adopted or, as Gobi put it, 'inherited' by white British women (Chapters 3 and 4).

Although women are crucial in forming and maintaining kinship relationships, children and fathers are also central in making kinship. Among the London families, it is ultimately through the elaborate strands or links of full and half-siblingship (primarily through the fathers) that the family becomes extended. Furthermore, despite separation, divorce death or migration, kinship bonds are maintained transgenerationally (primarily through the agency of women) in order that the sibling relationships are maintained.

Collectively, as with the Caribbean creole kinship, the features found among these London families are adaptive strategies conceived in an environment of changing social and cultural forces, including processes of violence, conflict, and tension. They maximise 'ties of conjugality, consanguinity, and affinity' (Besson 2002a: 281) with the wider family ties, creating bases of identity and mutual aid. Moreover, given their London context, they challenge previous notions about British kinship (Firth et al. 1970) and what is 'truly British' (James 1997).

Finally, as a process, creolisation continues among the current generation of mixed-heritage families. For, although the earlier families have struggled and devised innovative strategies for survival, their children continue, though in different ways, to become agents in securing a place, and of belonging, within British society (Chapter 7). It is particularly among these mixed-heritage children that the notion of ethnic identity as a stable entity is challenged. As part of the process of creolisation, ethnic identity or social positioning is not a fixed process, but a dynamic one that undergoes 'unstable points of identification or suture that are made in the discourses of history and culture. Not an essence but a *positioning*' (Hall 1990: 226). It is a process of becoming rather than being (Hall 1996a: 4). In their local context, they have used the resources of history, language and culture to experiment and to innovate their own construction of ethnic identity. They have challenged the

externally represented ethnic categories so that their own representations of themselves may be acknowledged, thereby demonstrating that identities are not always about external representations, but may also be constituted from within (ibid.).

With particular reference to the census, we find, even at an institutional level, that the children who are the products of these families are ‘coming-to-terms-with [their] “routes” [their ancestry]’ (ibid.), and actively claiming their mixed-heritage ‘roots’ on British soil. We are seeing the emergence of a ‘mixed’ ethnicity comparable to the emergence of ‘creole’ ethnicities in the Caribbean (Besson 2003; Burton 1997; Hintzen 2002). Effectively, these children who are the products of mixed African-Caribbean and white British parents have illustrated that identity, including ethnic identity, is constructed through human sociability, is situationally and locally defined, may be strategically manipulated and is capable of change at both the individual and collective levels (see Jenkins 2004).

In sum, I see the process of kinship in these London families as bearing a close resemblance to the process of creolisation. As with the process of creolisation, their kinship processes are processes of becoming that occurred over time and through generations, and evolved against the constraints they encountered along the way, into their own dynamic transformations. And as with creolisation, through the rejection, borrowing and mixing of cultural elements from both Britain and the Caribbean, they have innovated their own forms of family in the local context, thus asserting their claim of belonging in London.

### **Implications and practical significance**

The research purpose, design, analysis and interpretation of this book are qualitative and exploratory. In conducting the research, I did not set out to prove or disprove a hypothesis. I undertook this research in order to *explore* a phenomenon of a group of people about which very little is known, in order to become familiar with their social lives or ‘life-worlds’ (Berg 1995) and to gain insight and understanding about them. Because I am interested in their social lives or life-worlds, my focus is on the meanings individuals assign to experience. Thus, I am interested in how individuals in mixed African-Caribbean and white British extended families arrange themselves and their settings and how they make sense of their surroundings through social structures, social roles, symbols, rituals, etc. In other words, I am interested in emotions, motivations, symbols and their meanings, empathy, behavioural routines, experiences, the various conditions affecting their routines and settings and other subjective

aspects associated with the evolving lives of individuals within this group.

The use of qualitative techniques provided a means of accessing unquantifiable information about the people I spoke to and observed, as well as those people represented by their personal narratives (some either alive but absent, or no longer alive) through letters, photographs, diaries, etc. Qualitative techniques allowed me to share in the understandings and perceptions of the people I studied and to explore how they structure and give meaning to their daily lives, as well as make sense of themselves and others. Analysis of such qualitative data allowed me to discuss in detail the various social contours and processes individuals in these families use to create and maintain their social realities over time and across generations.

Many of the evidence in an exploratory research such as this one are directly observable and, as such, may be viewed as objective (Schwartz & Jacobs 1979). Nevertheless, 'certain elements of symbolism, meaning, or understanding usually require consideration of the individual's own perception and subjective apprehensions' (Berg 1995: 10). Therefore, my conclusions may well lead to other perspectives and interpretations. Because it is original research, it provides a vantage point for more precise research problems for further studies and interpretations. Thus, I believe that this research has methodological, empirical, theoretical and practical implications and significance.

In terms of the *methodological* implications and significance of this research, there has been a big gap in kinship studies in cities. I suspect that one of the difficulties is the lack of appropriate anthropological techniques to handle the complexities in urban kinship research. Anthropologists have traditionally studied homogeneous 'whole cultures' and have been very hesitant to engage with cultures that are mixed or in the process of mixing with other cultures, both for conceptual and for methodological reasons. This research introduces some modifications to traditional anthropological techniques of participant observation to enable the study of complex urban families with members scattered across the city. Individuals within these families do not exist in bounded 'communities'. They have busy lives, and spending extended periods of time within their homes observing, interacting and participating in their daily activities is impossible. Therefore, other methodological tools such as the use of the telephone, emails and joint leisure activities at participants' convenience had to be employed.

'Mixed-race'/'mixed-heritage' families are one of a number of family forms that are becoming more prominent in the modern globalised world (such as step-families, gay families and transnational families). *Empirically*, this research has a number of implications that could be taken up in future research.

1. It provides data that can be used for comparison on mixing with other groups, as well as for comparison with mixed-race families and with same-race families not just in Britain but also beyond.
2. It is new British urban kinship research. Mixed-race/heritage families like same-race/heritage families are sites of support and strength as well as conflict and pains. Therefore, I believe that they warrant social science inquiry and that research on such families adds a new perspective on British kinship and encourage theoretical debates about them.
3. It provides research that highlights the significance of children and siblings in creating the links between extended families. This is an area of research that has been ignored or given little emphasis in British kinship studies.
4. It provides research that offers insights into the dynamics and functioning of female-headed homes with multiple-race children.
5. It provides current research on mixed sociability (social interactions between African-Caribbeans and white British people) not only in terms of families, but also in terms of neighbourhoods.
6. It provides an in-depth cross-generational study of kinship. By analysing families in terms of their history across generations, I believe this study has opened up an area of research that offers promising ways of looking at continuity and change within families, in order understand how they arrived at the here and now. It also offers a way of understanding the influences and concerns that they had from the past, including, when for some families, the iconic figure is no longer alive.

This research also has *theoretical* implications and significance. Firstly, it addresses the argument that rigorous and limited family norms have given way to a wide range of experimental and innovative family forms (Giddens 1992) in a changing global society such as London, reflecting the more general theoretical debate between structure and agency. Secondly, by employing the concept of creolisation as a theoretical framework for analysis, I have shown how a theory that was developed in post-colonial Caribbean contexts has relevance in a Western post-imperial ethnically diverse context. Particularly with respect to family structures carved out of situations of continued conflict and adaptation, as a result of migration and globalisation. Furthermore, like individuals and cultures, theories also migrate (Sheller 2003).

Finally, I believe this research also has *practical* significance. Fifty years ago mixed African-Caribbean and white British extended families were uncommon, but today there are many of them particularly in London. In many ways, however, they have remained uncommon in the ways they create their social worlds and in the questions they still pose

for individuals and for the society. Thus, these families demonstrate the hard work that is required for survival in a context that is still ambivalent about their existence. Thus, their survival strategies may have wider social implications in a multicultural/hyper-diverse/intercultural society such as London. Their solutions achieved through communication, experimentation and innovation could hold important clues for politicians, institutions and city planners of hyper-diverse intercultural cities who are interested in creating 'racial harmony' and 'community cohesion'. A possible solution that may be deduced from their examples points to the creation of more public spaces that encourage mixing between groups, where individuals could come together to share common interests and realise some common values, for example, in art, music, sports, literature, etc. Providing more inter-racial/cultural public spaces has the potential to reduce the strain associated with mixed-race relationships/marriages/families, and thus more generally enhance positive race relations.



## Bibliography

- Abenaty, Francis K. (2003), 'Family and Social Networks among St. Lucian Migrants in Britain: The Birmingham Connection', *Community, Work & Family* 6 (1): 17-28.
- Abrahams, R. D. (1985), 'Our Native Notions of Story', *New York Folklore* 1: 37-47.
- Alexander, Jack (1996), 'Love, Race, Slavery and Sexuality in Jamaican Images of the Family', in Christine Barrow (ed.), *Family in the Caribbean: Themes and Perspectives*, 182-202. Kingston: Ian Randle Publishers.
- Ali, S. (2003), *Mixed-Race, Post-Race: Gender, New Ethnicities and Cultural Practices*. Oxford: Berg.
- (2007), 'Gendering Mixed-Race, Deconstructing Mixedness', in Jessica Sims (ed.), *Mixed Heritage: Identity, Policy and Practice*, 7-9. London: The Runnymede Trust.
- Alibhai-Brown, Y. (2001), *Mixed Feelings: The Complex Lives of Mixed-Race Britons*. London: The Women's Press Ltd.
- Allan, Graham (1999), *The Sociology of the Family*. Oxford: Blackwell Publishers.
- Allen, Carolyn (2002), 'Creole: The Problem of Definition', in Verene Shepherd & Glen Richards (eds.), *Questioning Creole: Creolisation Discourses in Caribbean Culture*, 47-53. Kingston: Ian Randle Publishers.
- Alleyne, M. C. (1985), 'A Linguistic Perspective on the Caribbean', in S. Mintz & S. Price (eds.), *Caribbean Contours*, 155-180. Baltimore: The Johns Hopkins University Press.
- (1988), *Roots of Jamaican Culture*. London: Pluto Press.
- (2002), *The Construction and Representation of Race and Ethnicity in the Caribbean and the World*. Kingston: University of the West Indies Press.
- Amit, V. (2000), *Constructing the Field: Ethnographic Fieldwork in the Contemporary World*. London: Routledge.
- Arensberg, C. M. & S. T. Kimball (1968), *Family and Community in Ireland*. Cambridge: Harvard University Press.
- Arthur, S., D. Snape & G. Dench (2003), *The Moral Economy of Grandparenting*. London: Institute of Community Studies.
- Aspinall, P. (2002), 'Collective Terminology to Describe the Minority Ethnic Population: The Persistence of Confusion and Ambiguity in Usage', *Sociology* 36 (4): 803-816.
- (2004), 'The Conceptualisation and Categorization of Mixed Race/Ethnicity in Britain and North America: Identity Options and The Role of The State', in Jayne O. Ifeunigwe (ed.), *Mixed Race Studies*, 255-260. London: Routledge.
- (2008), 'The Categorization of African Descent Populations in Europe and the USA: Should Lexicons of Recommended Terminology Be Evidence-Based?', *Public Health* 122: 61-69.
- (2009a), "'Mixed race", "Mixed Origins" or What? Generic Terminology for the Multiple Racial/Ethnic Group Population', *Anthropology Today* 25 (2): 3-8.
- (2009b), 'Concepts, Terminology, and Classifications for the "Mixed" Ethnic or Racial Group in the United Kingdom', *Journal of Epidemiology & Community Health*. Online First, [www.doi.org/10.1136/088294.1-7](http://www.doi.org/10.1136/088294.1-7).

- (2009c), 'The Future of Ethnic Classifications', *Journal of Ethnic and Migration Studies* 19 (1): 1417-1435.
- Back, L. (1996), *New Ethnicities and Urban Culture: Racisms and Multiculture in Young Lives*. London: Routledge.
- Back, L. & J. Solomos, (2000), *Theories of Race and Racism: A Reader*. London: Routledge.
- Bagley, C. & L. Young, (1979), 'The Identity, Adjustment, and Achievement of Transracially Adopted Children: A Review and Empirical Report', in G. K. Verma & C. Bagley (eds.), *Race, Education, and Identity*. London: MacMillan.
- Ballard, R. (1994), *Desh Pardesh: The South Asian Experience in Britain*. London: Hurst.
- Bannerji, H. (1987), 'Introducing Racism: Notes towards an Anti-Racist Feminism', *Resources For-Feminist Research* 16 (1): 10-12.
- Banton, Michael (1955), *The Coloured Quarter: West African and West Indian immigrants in the East End of London*. London: Jonathan Cape.
- (1960), *White and Coloured: The Behaviour of British People towards Coloured immigrants*. New Brunswick: Rutgers University Press.
- (1967), *Race Relations*. London: Tavistock.
- (1987), *Racial Theories*. Cambridge: Cambridge University Press.
- Barn, Ravindar (2001), 'Caribbean Families and the Child Welfare System in Britain', in Harry Goulbourne & M. Chamberlain (eds.), *Caribbean Families in Britain and the Trans-Atlantic World*, 204-218. London: MacMillan Education Ltd.
- Barnes, C., P. Thompson, G. Daniel & N. Burchardt (1998), *Growing Up In Stepfamilies*. Oxford: Clarendon Press.
- Barrett, S. R. (1994), *Paradise: Class, Commuters, and Ethnicity in Rural Ontario*. Toronto: University of Toronto Press.
- (1997), *Anthropology: A Student's Guide to Theory and Method*. Toronto: University of Toronto Press.
- Barrow, Christine, (1996), *Family in the Caribbean: Themes and Perspectives*. Kingston: Ian Randle Publishers
- (1998), 'Caribbean Masculinity and Family: Revisiting "Marginality" and "Reputation"', in Christine Barrow (ed.), *Caribbean Portraits: Essays on Gender Ideologies and Identities*, 339-358. Kingston: Ian Randle publishers.
- Barth, F. (1969), *Ethnic Groups and Boundaries: The social organization of cultural difference*. London: Allen & Unwin.
- (1989), 'The Analysis of Culture in Complex Societies', *Ethnos* 54 (3-4): 120-142.
- Bauer, Elaine, & P. Thompson, (2004), "'She's always the person with a very global vision": The Gender Dynamics of Migration, Narrative Interpretation and the Case of Jamaican Transnational Families', *Gender and History* 16(2): 334-375.
- Bauer, Elaine & P. Thompson (2006), *Jamaican Hands Across the Atlantic*. Kingston: Ian Randle Publishers.
- Bell, C. (1968), *Middle Class Families*. London: Routledge and Kegan Paul.
- Benedict, R. ([1943] 1983), *Race and Racism*. London: Routledge and Kegan Paul.
- Benson, S. (1981), *Ambiguous Ethnicity: Interracial Families in London*. Cambridge: Cambridge University Press.
- Benson, J. (2005), *Affluence and Authority: A Social History of 20<sup>th</sup> Century Britain*. New York: Oxford University Press.
- Berg, B. L. (1995), *Qualitative Research Methods for the Social Sciences*, second edition. Toronto: Allyn and Bacon.
- Berremman, Gerald D. (1962), *Behind Many Masks*. Ithaca: Society for Applied Anthropology.
- Berrington, A. (1994), 'Marriage and Family Formation among the White and Ethnic Minority Populations in Britain', *Ethnic and Racial Studies* 17 (3): 517-46.

- (1996), 'Marriage patterns and inter-ethnic union', in D. Coleman & J. Salt (eds.), *Ethnicity in the 1991 Census: Volume 1, Demographic Characteristics of the Ethnic Minority Population*, 178-212. London: HMSO.
- Bertaux, D. & P. Thompson (1993), *Between Generations: Family Models, Myths and Memories*. Oxford: Oxford University Press.
- Berthoud, R. (2000), *Family Formation in Multi-Cultural Britain: Three Patterns of Diversity*. Institute of Social and Economic Research: University of Essex.
- Berthoud, R., & S. Beishon (1997), 'People, Families and Households', in T. Madood & R. Berthoud (eds.), *Ethnic Minorities in Britain: Diversity and Disadvantage*, 18-59. London: Policy Studies Institute.
- Besson, Jean (1993), 'Reputation and Respectability Reconsidered: A New Perspective on African-Caribbean Peasant Women', in Janet Momsen (ed.), *Women and Change in the Caribbean*, 15-37. Kingston: Ian Randle.
- (1995), 'The Creolisation of African-American Slave Kinship in Jamaican Free Village and Maroon Communities', in Stephan Palmie (ed.), *Slave Cultures and the Cultures of Slavery*, 187-209. Knoxville: The University of Tennessee Press.
- (2002a), *Martha Brae's Two Histories: European Expansion and Caribbean Culture-Building in Jamaica*. Chapel Hill: The University of North Carolina Press.
- (2002b), 'Land, Territory and Identity in the Deterritorialized, Transnational Caribbean', in M. Saltman (ed.), *Land and Territoriality*, 175-208. Oxford: Berg.
- (2003), 'Euro-Creole, Afro-Creole, Meso-Creole: Creolisation and Ethnic Identity in West-Central Jamaica', in Gordon Collier & Ulrich Fleischmann (eds.), *A Pepper-Pot of Cultures: Aspects of Creolisation in the Caribbean*, 169-188. Amsterdam: Editions Ropodi B. V.
- Black, M. L. (1995), 'My Mother Never Fathered Me: Rethinking Kinship and the Governing of Families', *Social and Economic Studies* 44 (1): 49-71.
- Bolland, Nigel O. (2002), 'Creolisation and Creole Societies: A Cultural Nationalist View of Caribbean Social History', in Verene A. Shepherd & Glen L. Richards (eds.), *Questioning Creole: Creolisation in Discourses in Caribbean Culture*, 15-46. Kingston: Ian Randle.
- Bonnett, A. (2008), 'White Studies Revisited', *Ethnic and Racial Studies* 31 (1): 185-196.
- Bornat, J. (1989), 'Oral History As a Social Movement: Reminiscence and Older People', *Oral History* 17: 16-24.
- Bott, E. (1957), *Family and Social Network*. London: Tavistock Publications Limited.
- Bouquet, M. (1993), *Reclaiming English Kinship: Portuguese Refractions on British Kinship Theory*. Manchester: Manchester University Press.
- (2001), 'Making Kinship, with Old Reproductive Technology', in S. Franklin & S. McKinnon (eds.), *Relative Values: Reconfiguring Kinship Studies*, 85-115. Durham: Duke University Press.
- Bourdieu, P. (1977), *Outline of A Theory of Practice*. Cambridge: Cambridge University Press.
- (1990), *The Logic of Practice*. Cambridge: Polity Press.
- Brannen, J., & M. O'Brien (1995). *Childhood and Parenting*. London: Institute of Education, University of London.
- Brathwaite, K. (1971), *The Development of Creole Society in Jamaica, 1770-1820*. Oxford: Clarendon Press.
- Brown, T. (1985), *Ireland: A Social and Cultural History 1922-1985*. Glasgow: Harper and Collins Publishers.
- Bulmer, M., & J. Solomos (1999), *Ethnic and Racial Studies Today*. London: Routledge.
- Burns, A. (1995), 'Mother-Headed Families: Here to Stay?', in J. Brannen & M. O'Brien (eds.), *Childhood and Parenting*, 157-174. London: Institute of Education, University of London.

- Burton, R.D.E. (1997), *Afro-Creole: Power, Opposition, and Play in the Caribbean*. London: Cornell University Press.
- Bush, B. (1990), *Slave Women in Caribbean Society: 1650-1838*. London: James Currey.
- Bush, M. (2004), *Breaking the Code of Good Intentions: Everyday Forms of Whiteness*. Lanham, MD: Rowan and Littlefield.
- Byron, M. (1994), *Post-War Migration to Britain: The Unfinished Cycle*. Aldershot: Avebury.
- (1998), 'Migration, Work and Gender: The Case of Post-War Labour Migration from the Caribbean to Britain', in M. Chamberlain (ed.), *Caribbean Migration: Globalised Identities*, 217-231. London: Routledge.
- Bryon, M. & S. Condon (2008), *Migration in Comparative Perspective: Caribbean Communities in Britain and France*. London: Routledge.
- Caballero, C. (2007), "'Mixed" Families: Assumptions and New Approaches', in Jessica Sims (ed.), *Mixed Heritage – Identity, Policy and Practice*, 22-24. London: The Runnymede Trust.
- Caballero, C., R. Edwards & S. Puthussery (2008), *Parenting 'Mixed' Children: Negotiating Difference and Belonging in Mixed Race, Ethnicity and Faith Families*. London: Joseph Rowntree Foundation.
- Caplan, Pat (1997), *African Voices, African Lives: Personal Narratives from a Swahili Village*. London: Routledge.
- Carsten J. (1997), *The Heat of the Hearth: The Process of Kinship in a Malay Fishing Community*. Oxford: Clarendon Press.
- (2000), *Cultures of Relatedness: New Approaches to the Study of Kinship*. Cambridge: Cambridge University Press.
- (2004), 'The Substance of Kinship and the Heat of the Hearth: Feeding, Personhood, and Relatedness among Malays in Pulau Langkwi', in R. Parkin & L. Stone (eds.), *Kinship and Family: An Anthropological Reader*, 309-327. Oxford: Blackwell Publishing.
- Carsten, J. & S. Hugh-Jones, (1995), *About the House: Levi-Strauss and Beyond*. Cambridge: Cambridge University Press.
- Chamberlain, M. (1997), *Narratives of Exile and Return*. London: The MacMillan Press Ltd.
- (1999), "'Brothers and Sisters, Uncles and Aunts": A Lateral Perspective on Caribbean Families', in E. Silva & C. Smart (eds.), *The New Family*, 129-142. London: Sage.
- (2001a), 'Migration, the Caribbean and the Family', in H. Goulbourne & M. Chamberlain (eds.), *Caribbean Families in Britain and the Trans-Atlantic World*, 32-47. London: MacMillan Education Ltd.
- (2001b), 'Narratives of Caribbean families in Britain and the Caribbean', in H. Goulbourne & M. Chamberlain (eds.), *Caribbean Families in Britain and the Trans-Atlantic World*, 117-132. London: MacMillan Education Ltd.
- (2003), 'Rethinking Caribbean Families: Extending the Links', *Community, Work & Family* 6 (1): 63-76.
- Chamberlain, M. (2005), 'Language, Identity and Caribbean Families: Transnational Narratives', in J. Besson & K. Fog Olwig (eds.), *Caribbean Narratives of Belonging: Fields of Relations, Sites of Identity*, 171-188. Oxford: Macmillan Caribbean.
- (2006), *Family Love in the Diaspora: Migration and the Anglo-Caribbean experience*. London: Transaction Publishers.
- Charles, N. & M. Kerr (1999), 'Women's Work', in Graham Allan (ed.), *The Sociology of the Family*, 191-210. Oxford: Blackwell Publishers.
- Chevannes, B. (1993), 'Sexual Behaviour in Jamaicans: A Literature Review', *Social and Economic Studies* 42: 1-45.
- (2001), *Learning To Be A Man: Culture, Socialization and Gender Identity in Five Caribbean Communities*. Kingston: The University of the West Indies Press.
- Clarke, Edith (1999 [1957]), *My Mother Who Fathered Me: A Study of The Families in Three Selected Communities in Jamaica*. Kingston: The University of the West Indies Press.

- Clifford, James (1992), 'Traveling Cultures', in L. Grossberg, C. Nelson & P. A. Treichler (eds.), *Cultural Studies*, 96-116. New York: Routledge.
- Cohen, A. (1996), 'Ethnicity and Politics', in J. Hutchinson & A. Smith (eds.), *Ethnicity*, 83-84. Oxford: Oxford University Press.
- Collier, G. & Fleischmann U. (2003), *A Pepper-Pot of Cultures: Aspects of Creolisation in the Caribbean*. Amsterdam: Editions Rodopi.
- Commission for Racial Equality (2007), <http://83.137.212.42/sitesarchive/cre/research/crereserch.html>.
- Dangerfield, G. (1976), *The Damnable Question: A Study of Anglo-Irish Relations*. Boston: Little Brown.
- Davidoff, L. & Catherine Hall (1987). *Family Fortunes: Men and Women of the English Middle Class, 1780-1850*. Chicago: The University of Chicago Press.
- Davidson, R. B. (1962). *West Indian Migrants*. London: Oxford University Press.
- Deakin, N. (1970). *Colour, Citizenship and British Society*. London: Panther Books.
- Dench, G. (1992), *From Extended Family to State Dependency*. London: Institute of Community Studies.
- (2003), *Rediscovering Family*. London: Hera Trust.
- Dench, G. & J. Ogg (2002), *Grandparenting in Britain: A Baseline Study*. London: Institute of Community Studies.
- Dexter, L.A. (1958), 'A Note on Selective Inattention in Social Science', *Social Problems* 6: 176-182.
- Douglas, M. (1984), *Food in The Social Order: Studies of Food and Festivities in Three American Communities*. New York: Russell Sage Foundation.
- Driver, G. (1982), 'West Indian Families: An Anthropological Perspective', in R. N. Rapoport, M. P. Fogarty, & R. Rapoport (eds.), *Families in Britain*, 205-219. London: Routledge & Kegan Paul.
- Durojaiye, M.O.A. (1970), 'Patterns of Friendship Choice in an Ethnically Mixed Junior School', *Race* 13 (2): 189-200.
- Edwards, J. & M. Strathern (2000), 'Including Our Own', in Janet Carsten (ed.), *Cultures of Relatedness*. Cambridge: Cambridge University Press.
- Edwards, R. (2008), *Researching Families and Communities: Social and Generational Change*. Abingdon: Routledge.
- Edwards, R., L. Hadfield, H. Lucey & M. Mauthner (2006), *Sibling Identity and Relationships: Sisters and Brothers*. London: Routledge.
- Eshleman, J. R. & J. N. Clarke (1978), 'Myths and Biases in Marital/Family Studies', in L. Morris & S. Lyon (eds.), *Gender Relations in Public and Private*. London: MacMillan Press Ltd.
- Essed, P. & S. Trienekens (2008), "'Who wants to feel white?" Race, Dutch culture and contested identities', *Ethnic and Racial Studies* 31 (1): 52-72.
- Fanon, Frantz (1963), *The Wretched of the Earth*. New York: Grove Press.
- (1967), *Black Skin White Masks*. New York: Grove Press.
- Finch J. (1985), 'Work, the family and the home', *International Journal of Social Economics* 12: 26-35.
- (1989), *Family Obligations and Social Change*. London: Polity Press.
- (2000), *Passing On: Kinship and Inheritance in England*. London: Routledge.
- Finch, J. & J. Mason (1993). *Negotiating Family Responsibilities*. London: Routledge.
- (1999), 'Obligations of Kinship in Contemporary Britain: Is There Normative Agreement?', in Graham Allan (ed.), *The Sociology of the Family*, 300-320. Oxford: Blackwell Publishers.
- Finnegan, Ruth (1994), 'Family Resources and experiences', in Ruth Finnegan and Michael Drake (eds.), *From Family Tree to Family History*, Chapter 4. Cambridge: Cambridge University Press.

- Finnegan, R. & M. Drake (1994), *From Family Tree to Family History*. Cambridge: Cambridge University Press.
- Firth, R. (1956), *Two Studies of Kinship in London*. London: University of London, The Athlone Press.
- Firth, R., Hubert J., & Forge A. 1970. *Families and Their Relatives*. London: Routledge & Kegan Paul.
- Foner, N. (1973), *Status and Power in Rural Jamaica*. New York: Teachers College Press.
- (1977), 'The Jamaicans: Cultural and Social Change among Migrants in Britain'. Chapter 5, in James L. Watson (ed.), *Between Two Cultures: Migrants and Minorities in Britain*, 120-150. Oxford: Basil Blackwell.
- 1979. *Jamaican Farewell: Jamaican Migrants in London*. London: Routledge & Kegan Paul.
- (2009), 'Gender and Migration: West Indians in Comparative Perspective', *International Migration* 47 (1): 3-29
- Fortes, M. (1949), *The Web of kinship among the Tallensi*. Oxford: Oxford University Press.
- Foucault, M. (1978). *The History of Sexuality: An Introduction*, Volume 1. Harmondsworth: Pelican.
- Frankenberg, R. (1966), *Communities in Britain: Social Life in Town and Country*. Hamondsworth: Penguin.
- Frazier, F. E. (1966 [1939]). *The Negro Family in the United States*. Chicago: The University of Chicago Press.
- Gallagher, T. (1985), 'A Tale of Two Cities: Communal Strife in Glasgow and Liverpool Before 1914', in R. Swift & S. Gilley (eds.), *The Irish in the Victorian City*, 106-129. London: Croom Helm.
- Geertz, C. (1973), *The Interpretation of Cultures*. New York: Basic Books.
- Giddens, A. (1992), *The Transformation of Intimacy: Sexuality, Love & Eroticism in Modern Societies*. Cambridge: Polity Press.
- Gilroy, P. (1987), *'There Ain't No Black in the Union Jack': The Cultural Politics of Race and Nation*. London: Hutchinson.
- Gilroy, P. (1993), *The Black Atlantic: Modernity and Double Consciousness*. London: Verso.
- Gittins, D. (1985), *The Family in Question Changing Households and Familiar Ideologies*. London: MacMillan Publishers Ltd.
- Glaser, B., & A. Strauss (1967), *The Discovery of Grounded Theory: Strategies for Qualitative Research*. Chicago: Aldine.
- Glass, R. (1961), *London's Newcomers: The West Indians Migrants*. London: George Allen & Unwin Ltd.
- Goddard, V. (1996), *Gender, Family and Work in Naples*. Oxford: Berg.
- Goldberg, D. T. (1990), *Anatomy of Racism*. Minneapolis: University of Minnesota Press.
- Goode, J. C. Curtis & J. Theophano (2003), 'Meal Formats, Meal Cycles, and Menu Negotiation in the Maintenance of an Italian-American Community', in M. Douglas (ed.), *Food in The Social Order: Studies of Food and Festivities in Three American Communities*, 143-218. Abingdon: Routledge.
- Goody, E. (1975), 'Delegations of Parental Roles in West Africa and the West Indies', in T. R. Williams (ed.), *Socialization and Communication in Primary Groups*. The Hague: Mouton Publishers.
- Gordon, A. (1964), *Intermarriage: Interfaith, Interracial, Interethnic*. Boston: Beacon Press.
- Gordon, S. A. (1987), "'I Go To "Tanties": The Economic Significance of Child-Shifting in Antigua, West Indies', *Journal of Comparative Family Studies* 18 (3): 427-443.
- Gorell Barnes, G., P. Thompson, G. Daniel G. & N. Burchardt (1998), *Growing Up in Stepfamilies*. Oxford: Clarendon Press.
- Goulbourne, H. (1991), *Ethnicity and Nationalism in Post-Imperial Britain*. Cambridge: Cambridge University Press.

- (1998), *Race Relations in Britain since 1945*. London: MacMillan.
- (1999), 'The Transnational Character of Caribbean Kinship in Britain', in S. McRae (ed.), *Changing Britain: Families and Households in the 1990s, 177-197*. Oxford: Oxford University Press.
- (2001a), 'The Socio-Political Context of Caribbean Families in the Atlantic World', in H. Goulbourne & M. Chamberlain (eds.), *Caribbean Families in Britain and the Trans-Atlantic World*, 12-31. London: MacMillan Education Ltd.
- (2001b), 'Trans-Atlantic Caribbean futures', in H. Goulbourne & M. Chamberlain (eds.), *Caribbean Families in Britain and the Trans-Atlantic World*, 234-242. London: MacMillan Education Ltd.
- (2002), *Caribbean Transnational Experience*. London: Pluto Press.
- Goulbourne, H. & M. Chamberlain (eds.) (2001), *Caribbean Families in Britain and the Trans-Atlantic World*. London: MacMillan Education Ltd.
- Goulbourne, H., T. Reynolds, J. Solomos & E. Zontini (2009), *Transnational Families: Ethnicities, Identities and Social Capital*. London: Routledge.
- Gow, P. (1991), *Of Mixed Blood: Kinship and History in Peruvian Amazonia*. Oxford: Clarendon Press.
- Green, C. A. (2006), 'Hierarchies of Whiteness in the Geographies of Empire: Thomas Thistlewood and the Barretts of Jamaica', *New West Indies Guide* 80 (1&2): 5-43.
- Hall, D. G. (1999), *In Miserable Slavery: Thomas Thistlewood in Jamaica 1750-86*. Kingston: The University of the West Indies Press.
- Hall, S. (1990), 'Cultural Identity and Diaspora', in J. Rutherford (ed.), *Identity: Community, Culture, Difference*, 222-237. London: Lawrence & Wishart.
- (1991), 'Old and New Identities, Old and New Ethnicities', in A. D. King (ed.), *Culture, Globalization and the World System: Contemporary Conditions for the Representation of Identity*. London: MacMillan.
- (1996a), 'Introduction: Who Needs "Identity?"', in S. Hall & P. Du Gay (eds.), *Questions of Cultural Identity*, 1-17. London: Sage Publications.
- (1996b), 'The New Ethnicities', in J. Hutchinson & A. D. Smith (eds.), *Ethnicity*, 161-163. Oxford: Oxford University Press.
- Hanks, Patrick (ed.), (1979), *Collins English Dictionary*. London: William Collins Sons & Co. Ltd.
- Hannerz, U. (1996), *Transnational Connections: Culture, People, Places*. London: Routledge.
- Hastrup, K. & K. Fog Olwig (1997), 'Introduction', in K. Fog Olwig & K. Hastrup (eds.), *Siting Culture: The Shifting Anthropological Object*. London: Routledge.
- Hawkes, G. (1999), 'Liberalizing Heterosexuality', in Graham Allan (ed.), *The Sociology of the Family*, 35-55. Oxford: Blackwell Publishers.
- Henriques, Fernando (1968), *Family and Colour in Jamaica*. London: MacGibbon & Kee.
- Henry, F. (1994), *The Caribbean Diaspora in Toronto: Learning to Live with Racism*. Toronto: University of Toronto Press.
- Henry, W. (2005), 'Projecting the "Natural": Language, Citizenship and Representation in Outernational Culture!', in J. Besson & K. Fog Olwig (eds.), *Caribbean Narratives of Belonging: Fields of Relations, Sites of Identity*, 280-298. Oxford: MacMillan Publishers.
- Herskovits, M. (1964 [1941]), *The Myth of the Negro Past*. New York: Octagon.
- Hewitt, R. (1986), *White Talk, Black Talk: Inter-Racial Friendship and Communication amongst Adolescents*. London: Cambridge University Press.
- Hickman, M. J. & B. Walter (1997), *Discrimination and the Irish Community in Britain*. London: Commission for Racial Equality.
- Hickman, M. J., S. Morgan, B. Walter & J. Bradley (2005), 'The Limitations of Whiteness and the Boundaries of Englishness: Second-generation Irish Identifications and Positionings in Multiethnic Britain', *Ethnicities* 5 (2): 160-182.
- Hill, C. (1965), *How Colour Prejudiced is Britain?* London: Victoria Gollancz Ltd.

- Hintzen, P.C. (2002), 'Race and Creole Ethnicity in the Caribbean', in Verene A. Shepherd & Glen L. Richards (eds.), *Questioning Creole: Creolisation in Discourses in Caribbean Culture*, 92-110. Kingston: Ian Randle Publishers: & Oxford: James Currey Publishers.
- Hiro, D. (1991), *Black British White British: A History of Race Relations in Britain*. London: Grafton Books.
- Hoetink, H. (1985), "'Race" and Color in the Caribbean', in S. Mintz & S. Price (eds.), *Caribbean Contours*, 55-84. Baltimore: The Johns Hopkins University Press.
- Holmes, C. (1988), *John Bull's Island: Immigration & British Society, 1871-1971*. London: MacMillan Education Ltd.
- Holy, L. (1996), *Anthropological Perspectives on Kinship*. London: Pluto Press.
- Horst H, & D. Miller (2005), 'From Kinship to Link-up: Cell phones and social networking in Jamaica', *Current Anthropology* 45 (5): 755-778
- (2006), *The Celphone: An Anthropology of Communication*. Oxford: Berg
- Hunt, J. & L. Hunt (1982), 'The dualities of career families', *Social Problems* 29: 499-510.
- Ifekwunigwe, J. O. (ed.) (2005), *'Mixed Race' Studies: A Reader*. London: Routledge.
- Ishwaran, K. & Ralph Piddington (1965), *Kinship and Geographical Mobility*. Leiden: E. J. Brill.
- Jackson, J. A. (1963), *The Irish in Britain*. London: Routledge & Kegan Paul.
- (1964), 'The Irish', in The Centre for Urban Studies (ed.), *London: Aspects of Change*, 293-308. London: MacGibbon & Kee.
- James, A. (1997), 'How British is British Food?', in P. Caplan (ed.), *Food, Health and Identity*, 71-86. London: Routledge
- James, W. & C. Harris (1993), *Inside Babylon: The Caribbean Diaspora in Britain*. London: Verso.
- James, C. E. (1999), *Seeing Ourselves: Exploring Race, Ethnicity and Culture*, second edition. Toronto: Thompson Educational Publishing, Inc.
- Jenkins, R. (1999), 'Ethnicity Etcetera: Social Anthropological Points of View', in M. Bulmer & J. Solomos (eds.), *Ethnic and Racial Studies Today*, 85-97. London: Routledge.
- (2004), *Social Identity*, second edition. London: Routledge.
- Johnson, W. R. & D. Warren (eds.) (1994), *Inside the Mixed Marriage: Accounts of Changing Attitudes, Patterns, and Perceptions of Cross-Cultural and Interracial Marriages*. New York: University Press of America.
- Keith, M. (2005), *After Cosmopolitanism? Multicultural Cities and the Future of Racism*. London: Routledge.
- Knowles, Caroline (2000), 'Here and There: Doing Transnational Fieldwork', in Vered Amit (ed.), *Constructing the Field: Ethnographic Fieldwork in the Contemporary World*, 54-70. London: Routledge.
- Laslett, Peter (1982), 'Forward', in R. N. Rapoport, M. Fogarty, & R. Rapoport (eds.), *Families in Britain*, xi-xv. London: Routledge & Kegan Paul.
- Leach, E. R. (1961), 'Polyandry, Inheritance, and the Definition of Marriage: With Particular Reference to Sinhalese Custom Law', in E. R. Leach, *Rethinking Anthropology*, 105-113. London: Athlone Press.
- Lewitt, P. (2001), *The Transnational Villagers*. Berkeley: University of California Press.
- (2002), 'The Ties That Change: Relations to the Ancestral Home over the Life Cycle', in P. Lewitt & M. C. Waters (eds.), *The Changing Face of Home: The Transnational Lives of Second Generation*, 123-144. New York: Russell Sage Foundation.
- Lewis, Oscar (1961), *The Children of Sanchez: Autobiography of a Mexican Family*. New York: Penguin Books.



- Lichtenberg, J. (1998), 'Racism in the Head, Racism in the World', in Naomi Zack, Laurie Sharage & Crispin Sartwell (eds.), *Race, Class, Gender, And Sexuality: The Big Questions*, 43-48. Malden: Blackwell Publishers Inc.
- Little, K. (1947), *Negroes in Britain*. London: Kegan Paul.
- Lowenthal, David (1972), *West Indian Societies*. London: Oxford University Press.
- MacPherson W. (1999), *The Stephen Lawrence Inquiry*. London: HMSO.
- Madood, T. (1997), 'Culture and Identity', in T. Madood, R. Berthoud, J. Lakey, J. Nazroo, P. Smith, S. Virdee, & S. Beishon, *Ethnic Minorities in Britain: Diversity and Disadvantage*, 390-338. London: Policy Studies Institute.
- Madood, T. S. Beishon & S. Virdee (1994). *Changing Ethnic Identities*. London: Policy Press Institute.
- Malinowski, B. (1930), 'Kinship', *Man* 30 (2): 19-29.
- Mansfield, P. (2006), 'Marital Relationships: Someone Who Is There for Me', in A. Buonfino & G. Mulgan (eds.), *Porcupines in Winter: The Pleasures and Pains of Living Together in Modern Britain*, 61-72. London: The Young Foundation.
- Marwick, Arthur (2003) (New Edition). *British Society Since 1945*. London: Penguin Books.
- Mason, D. (1999), 'The Continuing Significance of Race? Teaching Ethnic and Racial Studies in Sociology', in M. Bulmer & J. Solomos (eds.), *Ethnic and Racial Studies Today*, 13-28. London: Routledge.
- Maurer, B. (1997), *Recharting the Caribbean: Land, Law, and Citizenship in the British Virgin Islands*. Ann Arbor: The University of Michigan Press.
- Mauss, M. (1954), *The Gift: Forms and Functions of Exchange in Archaic Societies*. London: Cohen and West.
- Maylor, U. (2009), 'What is the Meaning of "Black"? Rethinking "Black" Respondents', *Ethnic and Racial Studies* 32 (2): 369-387.
- McRae, S. (1999), 'Cohabitation or Marriage? – Cohabitation', in Graham Allan (ed.), *The Sociology of the Family*, 172-190. Oxford: Blackwell Publishers.
- Merriman, N. (1993), *The Peopling of London: Fifteen Thousand Years of Settlement from Overseas*. London: The Museum of London.
- Miles, R. (1989), *Racism*. London: Routledge.
- Miller, D. & D. Slater (2000), *The Internet: An Ethnographic Approach*. Oxford: Berg.
- Mintz, S. W. (1971), 'The Caribbean as a Socio-Cultural Area', in Michael M. Horowitz (ed.), *Peoples and Cultures of the Caribbean: An Anthropological Reader*, 17-45. New York: The Natural History Press.
- (1974 [1960]), *Worker in the Cane: A Puerto Rican Life History*. New York: W.W. Norton & Company.
- (1989), *Caribbean Transformations*. New York: Columbia University Press.
- (1996), 'Ending Substances, Trying Theories: The Caribbean Region As Oikoumenè', *The Journal of the Royal Anthropological Institute* 2 (2): 289-311.
- (2002), 'Forward' to J. Besson's *Martha Brae's Two Histories: European Expansion and Caribbean Culture-Building in Jamaica*. Chapel Hill: The University of North Carolina Press.
- Mintz, S. & R. Price (1992 [1976]). *The Birth of African-American Culture: An Anthropological Perspective*. Boston: Beacon Press.
- Mintz, S. W. & Sally Price (eds.) (1985), *Caribbean Contours*. Baltimore: The Johns Hopkins University Press.
- Modell, J. S. (1994), *Kinship with Strangers: Adoption and Interpretations of Kinship in American Culture*. Berkeley: University of California Press.
- Moncrieffe, J. M. (2004), 'Ethnic Diversity and State Response in the Caribbean', Regional Background Paper for United Nations Development Program's (UNDP) Human Development Report. London: Overseas Development Institute.

- Murphy, M. & Wang D. (1999), 'Forecasting British Families into the Twenty-First Century', in Susan McRae (ed.), *Changing Britain: Families and Households in the 1990s*, 100-138. Oxford: Oxford University Press.
- Nachmias, C. F., & D. Nachmias (1992), *Research Methods in the Social Sciences* (4th ed.). New York: St. Martin's Press.
- Nettleford, R. (1970), 'The Melody of Europe, the Rhythm of Africa', in *Mirror, Mirror: Identity, Race and Protest in Jamaica*, 171-211. Kingston: Collins and Sangster.
- (1978), *Caribbean Cultural Identity: The Case of Jamaica: An Essay in Cultural Dynamics*. Kingston: Institute of Jamaica.
- Ng, R. (1993), 'Racism, Sexism, and Nation Building in Canada', in C. McCarthy & W. Crichlow (eds.), *Race Identity*, 50-59. London: Routledge.
- Norman, K. (2000), 'Phoning the Field: Meanings of Place and Involvement in Fieldwork "at Home"', in Vered Amit (ed.), *Constructing the Field: Ethnographic Fieldwork in the Contemporary World*, 120-146. London: Routledge.
- Office for National Statistics (2002), 'Census 2001: Ethnicity and Religion in England and Wales', [www.statistics.gov.uk/census2001/profiles/commentaries/ethnicity.asp](http://www.statistics.gov.uk/census2001/profiles/commentaries/ethnicity.asp).
- Office for National Statistics (2003), 'Census 2001, The UK Population: By Ethnic Group.' [www.statistics.gov.uk/CCI/nuget.asp?ID=273](http://www.statistics.gov.uk/CCI/nuget.asp?ID=273).
- Office for National Statistics (2004), 'Census 2001: Ethnicity and Religion in England and Wales (2002)', in Jayne O. Ifewunigwe (ed.), *Mixed Race Studies*, 250-254. London: Routledge.
- Olwig, K. F. (1981a), 'Finding a Place for the Slave Family: Historical Anthropological Perspectives', *Folk* 23: 245-258.
- (1981b), 'Women, "Matrifocality", and Systems of Exchange', *Ethnohistory* 28 (1): 59-78.
- (1993), *Global Culture, Island Identity: Continuity and change in the African-Caribbean community of Nevis*. Reading: Harwood Academic Publishers.
- (1999), 'Caribbean Place Identity: From Family Land to Region and Beyond', *Identities* 5 (4): 435-467.
- (2005), 'Narratives of Home: Visions of "Betterment" and Belonging in a Dispersed Caribbean Family', in J. Besson & K. Fog Olwig (eds.), *Caribbean Narratives of Belonging: Fields of Relations, Sites of Identity*, 189-205. Oxford: Macmillan Caribbean.
- (2007), *Caribbean Journeys: An Ethnography of Migration and Home in Three Family Networks*. Durham N. C: Duke University Press.
- Omi, M. & H. Winant, (1986), *Racial Formation in the United States*. New York: Routledge.
- Owen, C. (2004), '"Mixed Race" in Official Statistic', in Jayne O. Ifewunigwe (ed.), *Mixed Race Studies*, 244-249. London: Routledge.
- (2007), 'The Mixed Category in Census 2001', in Jessica Sims (ed.), *Mixed Heritage – Identity, Policy and Practice*, 1-4. London: The Runnymede Trust.
- Owen, D. (1996), 'Black-Other: The Melting Pot', in Ceri Peach (ed.), *Ethnicity in the 1991 Census*, Volume 2, 66-94. London: HMSO.
- (2001), 'A Profile of Caribbean Huseholds and Families in Great Britain', in Harry Goulbourne & Mary Chamberlain (eds.), *Caribbean Families in Britain and the Trans-Atlantic World*, 64-91. London: MacMillan Education Ltd.
- Pahl, J. (1989), *Money and Marriage*. London: MacMillan Education Ltd.
- Parry, O. (2000), *Male Underachievement in High School Eeducation in Jamaica, Barbados and St. Vincent and the Grenadines*. Kingston: Canoe Press.
- Patterson, O. (1975), 'Context and Choice in Ethnic Allegiance: A Theoretical Framework and Caribbean Case Study', in N. Glazer & D. Moynihan (eds.), *Ethnicity: Theory and Experience*, 305-349. Cambridge: Harvard University Press.
- Patterson, S. (1965). *Dark Strangers: A Study of West Indians in London*. Middlesex: Penguin Books.

- Peach, C. (1968). *West Indian Migration to Britain: A Social Geography*. London: Oxford University Press.
- (1996), 'Black Caribbeans: Class, Gender and Geography', in *Ethnicity in the 1991 Census*. Ceri Peach (ed.), Volume 2: 25-43. London: HMSO.
- Phillips, M. & T. Phillips (1999), *Windrush: The Irresistible Rise of Multi-Racial Britain*. London: Harper Collins Publishers.
- Phillipson, C., N. Ahmed and J. Latimer (2003), *Women in Transition: A study of the experiences of Bangladeshi women living in Tower Hamlets*. University of Bristol: Polity Press.
- Phillipson, C., E. Al-Haq, S. Ullah & J. Ogg (2000), 'Bangladeshi families in Bethnal Green: Older People, Ethnicity and Social Exclusion', in A. Warnes, L. Warren & M. Nolan (eds.), *Care Services for Later Life*, 273-290. London: Jessica Kingsley Publishers Ltd.
- Phillipson, C., M. Bernard, J. Phillips & J. Ogg. (2001), *The Family and Community Life of Older People*. London: Routledge.
- Portelli, A. (1991). *The Death of Luigi Trastulli and Other Stories*. New York: State University of New York Press.
- Platt, L. (2002), *Parallel Lives? Poverty among Ethnic Minority Groups in Britain*. London: PAG.
- (2009), *Ethnicity and Family: Relationships Within and Between Ethnic Groups: An Analysis Using the Labour Force Survey*. ISER: University of Essex.
- Price, R. (1983), *First Time: The Historical Vision of an Afro-American People*. Baltimore: The Johns Hopkins University Press.
- Ragone, H. (1994). *Surrogate Motherhood: Conception in the Heart*. Boulder, Colorado: Westview Press.
- Rapoport, R. N., M. Fogarty, & R. Rapoport (eds.) (1982), *Families in Britain*. London: Routledge & Kegan Paul.
- Rapoport, R. & R. Rapoport (1982), 'British Families in Transition', in R. N. Rapoport, M. P. Fogarty & R. Rapoport (eds.), *Families in Britain*, 475-499. London: Routledge & Kegan Paul.
- Rattray, R. S. (1923), *Ashanti*. The Clarendon Press: Oxford.
- Reary, D. (1998), *Class Work: Mothers' Involvement in Their Children's Primary Schooling*. London: Taylor and Francis.
- Rex, J. (1983), *Race Relations in Sociological Theory*. London: Routledge & Kegan Paul.
- Rex, J. & S. Tomlinson (1979), *Colonial Immigrants in British City: A Class Analysis*. London: Routledge and Kegan Paul.
- Reynolds, T. (2001), 'Caribbean Fathers in Family Lives in Britain', in H. Goulbourne & M. Chamberlain (eds.), *Caribbean Families in Britain and the Trans-Atlantic World*, 133-153. London: MacMillan Education Ltd.
- (2005), *Caribbean Mothers: Identity and Experience in the U.K.* London: Tufnell Press.
- Reynolds, T. & E. Zontini (2006), *A Comparative Study of Care and Provision Across Caribbean and Italian Transnational Families*. London: London South Bank University.
- Richmond, A. (1955), *The Colour Problem: A Study of Race Relations*. Harmondsworth: Penguin Books.
- Rogozinski, J. (1992), *A Brief History of the Caribbean*. Penguin: New York.
- Röhrig Assunção, M. (2005a), *Capoeira: The History of an Afro-Brazilian Martial Art*. Routledge: London.
- (2005b), 'Brazilian Popular Culture in Historical Perspective or the Curse and Blessings of Cultural Hybridism', *Bulletin of Latin American Research* 24 (2): 157-166.
- Rosen, A. (2003), *The Transformation of British Life 1950-2000: A Social History*. Manchester: Manchester University Press.
- Rosenblatt, P. C., C. Karis & R. Powell (1995), *Multiracial Couples: Black and White Voices*. California: Sage Publications.

- Rosser, C. & C. Harris, C. (1965), *The Family and Social Change*. London: Routledge & Kegan Paul.
- Root, M. P. (1992), *Racially Mixed People in America*. London: Sage Publications.
- (ed.) (1996), *The Multiracial Experience: Racial Borders as a Significant Frontier in Race Relations*. California: Sage Publications.
- (2004), 'Within, Between and Beyond Race', in Jayne O. Ifeunigwe (ed.), *Mixed Race Studies*, 43-48. London: Routledge.
- Ryan, L. (2004), 'Family Matters: (E)migration, Familial Networks and Irish Women in Britain', *The Sociological Review* 52 (3): 351-370.
- Samuel, R. & P. Thompson (eds.), (1990), *The Myths We Live By*. London: Routledge.
- Scanzoni, J. (1987), 'Families in the 1980s: Time to Refocus Our Thinking', *Journal of Family Issues* 8: 394-421.
- (1997), 'Changing Households in Britain: Do Families Still Matter?', *Sociological Review* 45: 591-620.
- Schmidt, B. E. (2003), 'The Presence of Vodou in New York City: The Impact of a Caribbean Religion on the Creolisation of a Metropolis', in Gordon Collier & Ulrich Fleischmann (eds.), *A Pepper-Pot of Cultures: Aspects of Creolisation in the Caribbean*, 213-233. Amsterdam: Editions Rodopi B. V.
- Schneider, D. M. (1980 [1968]), *American Kinship: A Cultural Account*. Chicago: University of Chicago Press.
- (1984), *Critique of the Study of Kinship*. Ann Arbor: University of Michigan Press.
- Schwartz, H., & J. Jacobs (1979), *Qualitative Sociology: A Method to the Madness*. New York: Free Press.
- Schwegler, A. (2003), 'The Linguistic Geography of "Criollo" in Spanish America: A Case of Enigmatic Extension and Restriction', in Gordon Collier & Ulrich Fleischmann (eds.), *A Pepper-Pot of Cultures: Aspects of Creolisation in the Caribbean*, 45-63. Amsterdam: Editions Rodopi B. V.
- Schweitzer, P. P. (2000), *Dividends of Kinship: Meanings and Uses of Social Relatedness*. London: Routledge.
- Scott, J. (1999), 'Family Change: Revolution or Backlash in Attitudes?', in Susan McRae (ed.), *Changing Britain: Families and Households in the 1990s*, 68-99. Oxford: Oxford University Press.
- Selvon, S. (1956), *The Lonely Londoners*. New York: Longman Publishing Group.
- Shalins, M. (1994), 'Goodby to Tristes Tropes: Ethnography in the Context of Modern World History', in Robert Borofsky (ed.), *Assessing Cultural Anthropology*, 377-394. New York: McGraw-Hill Inc.
- Sheller, M. (2003), 'Creolisation in Discourses of Global Culture', in S. Ahmed, C. Castañeda, A. Fortierand & M. Sheller (eds.), *Uprootings/Regrounding: Questions of Home and Migration*, 273-294. New York: Berg.
- Shepherd, V. & H. Beckles (2000), *Caribbean Slavery in the Atlantic World: A Student Reader*. Kingston: Ian Randle.
- Simpson, Bob (1998), *Changing Families: An Ethnographic Approach to Divorce and Separation*. Oxford: Berg.
- Sims, J. M. (2007), 'Thai-British Families: Towards a Deeper Understanding of "Mixedness"', in Jessicca Sims (ed.), *Mixed Heritage – Identity, Policy and Practice*, 10-13. London: The Runnymede Trust.
- Smart, C. & B. Neale (1999), *Family Fragments*. London: Polity Press.
- Smelser, N. (1982), 'The Victorian Family', in R. N. Rapoport, M. P. Fogarty & R. Rapoport (eds.), *Families in Britain*, 59-74. London: Routledge & Kegan Paul.
- Smith, M. G. (1957), 'The African Heritage in the Caribbean', in V. Rubin (ed.), *Caribbean Studies: A Symposium*, 34-46. Jamaica, Institute of Social and Economic Research: University College of the West Indies Press.

- (1962), *West Indian Family Structure*. Seattle: University of Washington Press.
- (1965), *The Plural Society in the British West Indies*. Berkeley: University of California Press.
- Smith, R. T. (1956), *The Negro Family in British Guiana: Family Structure and Social Status in the Villages*. London: Routledge & Kegan Paul.
- (1957), 'The Family in the Caribbean', in V. Rubin (ed.), *Caribbean Studies: A Symposium*, 67-75. Jamaica, Institute of Social and Economic Research: University College of the West Indies.
- (1987), 'Hierarchy and the Dual Marriage System in West Indian Society', in J. Fishbourne Collier, & S. J. Yanagisako (eds.), *Gender and Kinship: Essays Toward a Unified Analysis*, 163-196. Stanford: Stanford University Press.
- (1988), *Kinship and Class in the West Indies: A Genealogical Study of Jamaica and Guyana*. Cambridge: Cambridge University Press.
- (1996), *The Matrifocal Family: Power, Pluralism, and Politics*. London: Routledge.
- (2001), 'Caribbean Families: Questions for Research and Implications for Policy', in Harry Goulbourne & Mary Chamberlain (eds.), *Caribbean Families in Britain and the Trans-Atlantic World*, 48-62. London: MacMillan Education Ltd.
- Sniderman, P. M. & T. Piazza, (1993), *The Scar of Race*. Cambridge: Harvard University Press.
- Solomos, J. (1993), *Race and Racism in Britain*, second edition. London: MacMillan Press Ltd.
- (2003), *Race and Racism in Britain*, third edition. London: Palgrave MacMillan.
- Solomos, J. & L. Back (2000), 'Introduction: Theorising Race and Racism', in Les Back & J. Solomos (eds.), *Theories of Race and Racism: A Reader*, 1-28. London: Routledge.
- Song, M. (2003), *Choosing Ethnic Identity*. Cambridge: Polity Press.
- (2007), 'The Diversity of "the" Mixed Race Population in Britain', in Jessica Sims (ed.), *Mixed Heritage – Identity, Policy and Practice*, 5-7. London: The Runnymede Trust.
- (2010a), 'Is There "A" Mixed Race Group in Britain? The Diversity of Multiracial Identification and Experience'. Forthcoming in *Critical Social Policy*.
- (2010b), 'What Does "White" Mean? Interpreting the Choice of "Race" by Mixed Race Young People in Britain'. Forthcoming in *Sociological Perspectives*.
- Sontag, S. (1997), *On Photography*. Harmondsworth: Penguin.
- Spickard, C. H. (1992), 'The Illogic of American Racial Categories', in Maria P. P. Root (ed.), *Racially Mixed People in America*. London: Sage Publications.
- Stack, C. (1974), *All Our Kin: Strategies for Survival in a Black Community*. New York: Harper & Row.
- Stone, L. (2004), *Kinship and Family*. Oxford: Blackwell Publishing.
- Strathern, M. (1981), *Kinship at the Core*. Cambridge: Cambridge University Press.
- (1992a), *After Nature: English Kinship in the Late Twentieth Century*. Cambridge: Cambridge University Press.
- (1992b), *Reproducing the Future: Essays on Anthropology, Kinship and the New Reproductive Technologies*. Manchester: Manchester University Press.
- Strauss, A. L. (1987), *Qualitative Analysis for Social Scientists*. New York: Cambridge University Press.
- Thomas-Hope, E. (1998), 'Globalisation and the development of a migration culture', in Mary Chamberlain (ed.), *Caribbean Migration*, 188-199. London: Routledge.
- Thompson, P. (1997), 'Women, Men, and Transgenerational Family Influences in Social Mobility', in Daniel Bertaux and Paul Thompson (eds), *Pathways to Social Class: A Qualitative Approach to Social Mobility*, 32-61. Oxford: Clarendon Press.
- Thompson, P. (2000), *The Voice of The Past: Oral History*, third edition. Oxford: Oxford University Press.

- Thompson P. & E. Bauer (2000), 'Jamaican Transnational Families: Points of Pain and Sources of Resilience', *Wadabagei: A Journal of the Caribbean and its Diaspora* 3 (2): 1-36.
- (2002), 'Recapturing Distant Caribbean Childhoods and Communities: The Shaping of the Memories of Jamaican migrants in Britain and North America', *Oral History* 30 (2): 49-59.
- Tizard, B. & A. Phoenix (2002 [1993]), *Black, White or Mixed Race? Race and Racism in the Lives of Young People of Mixed Parentage*. London: Routledge.
- Tonkin, Elizabeth (1993). *Narrating Our Pasts: The Social Construction of Oral History*. Cambridge: Cambridge University Press.
- Trouillot, M. F. (1992), 'The Caribbean Region: An Open Frontier in Anthropological Theory', *Annual Review of Anthropology* 21: 19-42.
- (1998), 'Culture on the Edges: Creolisation in the Plantation Context', *Plantation Society in the America* 5 (1): 8-28.
- Twine, F. W. (1999), 'Transracial Mothering and Antiracism: The Case of White Birth Mothers of "Black" Children in Britain', *Feminist Studies* 25 (3): 729-746.
- Twine, F. W. & C. Gallagher (2008), 'Introduction: The Future of Whiteness: A Map of the "Third Wave"', *Ethnic and Racial Studies* 31 (1): 4-24.
- Wallman, S. (1983), 'Identity Options', in C. Fried (ed.), *Minorities: Community and Identity*, 69-78. New York: Springer-Verlag.
- Wallman, S. (1984), *Eight London Households*. London: Tavistock Publications.
- Walvin, J. (1973), *Black and White: The Negro in British Society*. London: Allen & Unwin.
- Weeks, J., B. Heaphy & C. Donovan (1999a), 'Families of Choice: Autonomy and Mutuality in Non-Heterosexual Relationships', in Susan McRae (ed.), *Changing Britain: Families and Households in the 1990s*, 297-315. Oxford: Oxford University Press.
- (1999b), 'Partners by Choice: Equality, Power and Commitment in Non-Heterosexual Relationships', in G. Allan (ed.), *The Sociology of the Family*, 111-128. Oxford: Blackwell Publishers.
- Weston, K. (1991). *Families we Choose: Lesbians, Gays, Kinship*. New York: Columbia University Press.
- Westwood, S., & P. Bhachu (1988). *Enterprising Women: Ethnicity, Economy, and Gender Relations*. London: Routledge.
- Willmott, P. & M. Young (1960), *Family and Class in a London Suburb*. London: Routledge & Kegan Paul.
- Wilson, A. (1987), *Mixed Race Children: A Study of Identity*. London: Allen & Unwin.
- Wilson, P. J. (1969), 'Reputation and Respectability: A Suggestion for Caribbean Ethnology', *Man* 4 (5): 70-84.
- (1973), *Crab Antics: A Caribbean Case Study of the Conflict Between Reputation and Respectability*. Prospect Heights: Waveland Press, Inc.
- Wright, P. (1966), *Lady Nugent's Journal of Her Residence in Jamaica from 1801 to 1805*. Kingston: Institute of Jamaica.
- Yanagisako, S. J. (1987), 'Mixed Metaphors: Native and Anthropological Models of Gender and Kinship', in J. F. Collier & S. J. Yanagisako (eds.), *Gender and Kinship: Essays towards a Unified Analysis*. Stanford University Press.
- Young, M. & P. Willmott (1957), *Family and Kinship in East London*. London: Routledge & Kegan Paul.
- (1973), *The Symmetrical Family*. New York: Pantheon Books.

# Appendix I

## Ethnic group question in the census

<b>What is your ethnic group?</b>	<input type="checkbox"/> 0 White <input type="checkbox"/> 1 Black-Caribbean <input type="checkbox"/> 2 Black-African <input type="checkbox"/> Black-other <i>please describe</i> <input type="text"/> <input type="text"/>
Please tick the appropriate box.	<input type="checkbox"/> 0 Indian <input type="checkbox"/> 1 Pakistani <input type="checkbox"/> 2 Bangladeshi <input type="checkbox"/> Chinese Any other ethnic group <i>please describe</i> <input type="text"/> <input type="text"/>
If the person is descended from more than one ethnic or racial group, please tick the group to which the person considers he/she belongs, or tick the 'Any other ethnic group' box and describe the person's ancestry in the space provided.	

Source: 1991 Census of Population, H enumeration form for private households, reproduced in Dale and Marsh (1993), p. 367

## Ethnic question for 2001 census for England and Wales

**What is your ethnic group?**

Choose one section from (a) to (e) then tick the appropriate box to indicate your cultural background.

(a) **White**

- British
- Irish
- Any other White background. Please describe:

\_\_\_\_\_

(b) **Mixed**

- White and Black Caribbean
- White and Black African
- White and Asian
- Any other mixed background. Please describe:

\_\_\_\_\_

(c) **Asian or Asian British**

- Indian
- Pakistani
- Bangladeshi
- Any other Asian background. Please describe:

\_\_\_\_\_

(d) **Black or Black British**

- Caribbean
- African
- Any other Black background. Please describe:

\_\_\_\_\_

(e) **Chinese or Other ethnic group**

- Chinese
- Any other. Please describe:

\_\_\_\_\_

Source: The 2001 Census of Population (1999), Cmnd 4253



## Appendix II

### Sample profile of mixed family households

**Table 1** *Relationship category: Legally married and together*

<i>Partners</i>	<i>Gender</i>	<i>Ethnic origin</i>	<i>Years together</i>	<i>Children</i>		
				<i>Mixed-race</i>	<i>Black</i>	<i>White</i>
Dawn	Female	White British	51	2		
Dusty	Male	African-Caribbean				
Tilly	Female	White British	24	3		
Fred	Male	African-Caribbean				
May	Female	White British	26	3		
Dollard	Male	African-Caribbean				
Rose	Female	White British	22	2		
Raleigh	Male	African-Caribbean				
Babette	Female	White British	42	4		
Owen	Male	African-Caribbean				
June	Female	Mixed	15	1	1	1
Adam	Male	White British				
Verna	Female	Mixed	9	1	2	
Ken	Male	White British				
Becky	Female	African-Caribbean	4	1		
Rodney	Male	White British				
Faye	Female	African-Caribbean	14	1		
Donavan	Male	White British				
Julie	Female	African-Caribbean	8	1		
Sid	Male	White British				
Anna	Female	African-Caribbean	4	1		
Carl	Male	White British				

**Table 2** *Relationship category: Legally married and parted*

<i>Partners</i>	<i>Gender</i>	<i>Ethnic origin</i>	<i>Years together</i>	<i>Children</i>		
				<i>Mixed-race</i>	<i>Black</i>	<i>White</i>
Jenny	Female	African-Caribbean	15	2		
Larry	Male	White British				
Maggie	Female	African-Caribbean	14	2		
Duncan	Male	White British				
Karen	Female	White British	9	3	2	1
Barry	Male	African-Caribbean				
Cathy	Female	White British	10	2		
Hubert	Male	African-Caribbean				
Paulette	Female	White British	25	6		
Francis	Male	African-Caribbean				
Olive	Female	White British	25	6		
Roy	Male	African-Caribbean				

**Table 3** *Relationship category: Cohabiting*

<i>Partners</i>	<i>Gender</i>	<i>Ethnic origin</i>	<i>Years together</i>	<i>Children</i>		
				<i>Mixed-race</i>	<i>Black</i>	<i>White</i>
Kelly	Female	African-Caribbean	4	2		
Patrick	Male	White British				
Petra	Female	African-Caribbean	3	3		
Garth	Male	White British				
Alice	Female	African-Caribbean	4	1	1	
Buster	Male	White British				
Pearl	Female	African-Caribbean	12			
Bert	Male	White British				
Magda	Female	White British	3	1		
Julius	Male	African-Caribbean				
Jane	Female	White British	17	3		
Richard	Male	African-Caribbean				
Katrina	Female	White British	6	2		1
John	Male	African-Caribbean				
Claris	Female	White British	8	2		
Justin	Male	African-Caribbean				

**Table 4** *Relationship category: Cohabiting but parted*

Partners	Gender	Ethnic origin	Years together	Children		
				Mixed-race	Black	White
Lucy	Female	White British	6	3		3
Ralph	Male	African-Caribbean				
Gobi	Female	White British	15	2	3	2
Randal	Male	African-Caribbean				
Betty	Female	White British	1	1		1
Troy	Male	African-Caribbean				
Pamela	Female	African-Caribbean	3	1		
Norris	Male	White British				
Lolly	Female	Mixed	3	1		
James	Male	White British				

**Table 5** *Relationship category: Visiting relationships*

Partners	Gender	Ethnic origin	Years together	Children		
				Mixed-race	Black	White
Carla	Female	African-Caribbean	14			
Joseph	Male	White British				
Keeley	Female	White British	3			
Robin	Male	African-Caribbean				
Merna	Female	White British	10	2		
Jordan	Male	African-Caribbean				

**Table 6** *Relationship category: Foster family*

Partners	Gender	Ethnic origin	Years together	Children		
				Mixed-race	Black	White
Jada	Female	White British	50		2	8
Lester	Male	White British				
Harold	Male	African-Caribbean	40			

**Table 7** *Female-headed households*

<i>Female</i>	<i>Ethnic origin</i>	<i>Children</i>		
		<i>Mixed-race</i>	<i>Black</i>	<i>White</i>
Merna	White British	2		
Gobi	White British	2	3	2
Lindsay	White British	2		
Lucy	White British	2		3
Betty	White British	1		1
Karen	White British	3		1
Jenny	African-Caribbean	2		
Lolly	Mixed	1		
Maggie	African-Caribbean	3		

## Appendix III

**Table 1** Cross-generational transmission (a partial sample)

<i>Families</i>	<i>Ethnic origin</i>	<i>Marriage</i>	<i>Education</i>	<i>Work</i>	<i>Housing</i>	<i>Mixed relationships</i>
<u>Babette</u> Parents	White British White British	Married Married	Primary Primary	Homemaker Bakers	Own Own	
<u>Owen</u> Parents	African-Caribbean African-Caribbean	Married Married	Secondary Primary	Electrician Farmers	Own Own	
Children	Mixed	2 married 1 cohabiting 1 single	3 college 1 secondary	1 butcher 3 semi- professionals Homemaker Manual	2 own 2 rent	1 son 1 daughter married to white British Brother
<u>Dawn</u> Parents	White British White British	Married Married	Primary Primary	Homemaker Manual	Own Own	
<u>Dusty</u> Parents	African-Caribbean African-Caribbean	Married Cohabiting	Primary Primary	Carpenter Manual	Own Own	Brother
Children	Mixed	1 divorced 1 married 2 married	University University 5 university 1 secondary Rest at school	Professional Professional 2 professionals 1 homemaker Rest at school	Rent Own 1 own 1 rent Rest at home	1 married to white British
Grandchildren	Mixed					

<i>Families</i>	<i>Ethnic origin</i>	<i>Marriage</i>	<i>Education</i>	<i>Work</i>	<i>Housing</i>	<i>Mixed relationships</i>
<u>Kelly</u> Parents	African-Caribbean African-Caribbean	Cohabiting Married	College Primary	Semi-professional Manual	Rent Rent	3 sisters
<u>Patrick</u> Parents	White British White British	Cohabiting Married	Secondary Primary	Manual	Rent Rent	1 uncle 2 sisters
Children	Mixed		Nursery			
<u>Jenny</u> Parents	African-Caribbean African-Caribbean	Divorced Divorced	University Primary	Professional Manual	Own Own	1 brother
<u>Larry</u> Parents	White British White British	Divorced Married	University College Secondary	Professional Homemaker	Own Own	Current wife
Children	Mixed		At school			
<u>June</u> Parents	Mixed White British African-Caribbean	Married Divorced	Secondary Primary	Clerical Manual	Rent Rent	All siblings Father's brother
<u>Adam</u> Parents	White British White British	Married Married	Secondary Secondary	Postman Semi-professional	Rent Own	
Children	1 white 2 mixed					

*Other IMISCOE titles*

*IMISCOE Research*

Rinus Penninx, Maria Berger, Karen Kraal, Eds.  
*The Dynamics of International Migration and Settlement in Europe: A State of the Art*

2006 (ISBN 978 90 5356 866 8)

(originally appearing in IMISCOE Joint Studies)

Leo Lucassen, David Feldman, Jochen Oltmer, Eds.

*Paths of Integration: Migrants in Western Europe (1880-2004)*

2006 (ISBN 978 90 5356 883 5)

Rainer Bauböck, Eva Ersbøll, Kees Groenendijk, Harald Waldrauch, Eds.  
*Acquisition and Loss of Nationality: Policies and Trends in 15 European Countries, Volume 1: Comparative Analyses*

2006 (ISBN 978 90 5356 920 7)

Rainer Bauböck, Eva Ersbøll, Kees Groenendijk, Harald Waldrauch, Eds.  
*Acquisition and Loss of Nationality: Policies and Trends in 15 European Countries, Volume 2: Country Analyses*

2006 (ISBN 978 90 5356 921 4)

Rainer Bauböck, Bernhard Perchinig, Wiebke Sievers, Eds.

*Citizenship Policies in the New Europe*

2007 (ISBN 978 90 5356 922 1)

Veit Bader

*Secularism or Democracy? Associational Governance of Religious Diversity*

2007 (ISBN 978 90 5356 999 3)

Holger Kolb, Henrik Egbert, Eds.

*Migrants and Markets: Perspectives from Economics and the Other Social Sciences*

2008 (ISBN 978 90 5356 684 8)

Ralph Grillo, Ed.

*The Family in Question: Immigrant and Ethnic Minorities in Multicultural Europe*

2008 (ISBN 978 90 5356 869 9)

Corrado Bonifazi, Marek Okólski, Jeannette Schoorl, Patrick Simon, Eds.  
*International Migration in Europe: New Trends and New Methods  
of Analysis*  
2008 (ISBN 978 90 5356 894 1)

Maurice Crul, Liesbeth Heering, Eds.  
*The Position of the Turkish and Moroccan Second Generation in Amsterdam  
and Rotterdam: The TIES Study in the Netherlands*  
2008 (ISBN 978 90 8964 061 1)

Marlou Schrover, Joanne van der Leun, Leo Lucassen, Chris Quispel, Eds.  
*Illegal Migration and Gender in a Global and Historical Perspective*  
2008 (ISBN 978 90 8964 047 5)

Gianluca P. Parolin  
*Citizenship in the Arab World: Kin, Religion and Nation-State*  
2009 (ISBN 978 90 8964 045 1)

Rainer Bauböck, Bernhard Perchinig, Wiebke Sievers, Eds.  
*Citizenship Policies in the New Europe: Expanded and Updated Edition*  
2009 (ISBN 978 90 8964 108 3)

Richard Black, Godfried Engbersen, Marek Okólski, Cristina Pantîru, Eds.  
*A Continent Moving West? EU Enlargement and Labour Migration from  
Central and Eastern Europe*  
2010 (ISBN 978 90 8964 156 4)

Charles Westin, José Bastos, Janine Dahinden, Pedro Góis, Eds.  
*Identity Processes and Dynamics in Multi-Ethnic Europe*  
2010 (ISBN 978 90 8964 046 8)

Rainer Bauböck, Thomas Faist, Eds.  
*Diaspora and Transnationalism: Concepts, Theories and Methods*  
2010 (ISBN 978 90 8964 238 7)

Cédric Audebert, Mohamed Kamel Doraï, Eds.  
*Migration in a Globalised World: New Research Issues and Prospects*  
2010 (ISBN 978 90 8964 1571)

#### *IMISCOE Reports*

Rainer Bauböck, Ed.  
*Migration and Citizenship: Legal Status, Rights and Political Participation*  
2006 (ISBN 978 90 5356 888 0)



Michael Jandl, Ed.

*Innovative Concepts for Alternative Migration Policies:  
Ten Innovative Approaches to the Challenges of Migration in the  
21st Century*

2007 (ISBN 978 90 5356 990 0)

Jeroen Doomernik, Michael Jandl, Eds.

*Modes of Migration Regulation and Control in Europe*

2008 (ISBN 978 90 5356 689 3)

Michael Jandl, Christina Hollomey, Sandra Gendera, Anna Stepien,  
Veronika Bilger

*Migration and Irregular Work In Austria: A Case Study of the Structure  
and Dynamics of Irregular Foreign Employment in Europe at the Beginning  
of the 21<sup>st</sup> Century*

2008 (ISBN 978 90 8964 053 6)

Heinz Fassmann, Ursula Reeger, Wiebke Sievers, Eds.

*Statistics and Reality: Concepts and Measurements of Migration in Europe*

2009 (ISBN 978 90 8964 052 9)

Karen Kraal, Judith Roosblad, John Wrench, Eds.

*Equal Opportunities and Ethnic Inequality in European Labour Markets:  
Discrimination, Gender and Policies of Diversity*

2009 (ISBN 978 90 8964 126 7)

Tiziana Caponio, Maren Borkert, Eds.

*The Local Dimension of Migration Policymaking*

2010 (ISBN 978 90 8964 232 5)

Raivo Vetik, Jelena Helemäe, Eds.

*The Russian Second Generation in Tallinn and Kohtla-Järve: The TIES  
Study in Estonia*

2010 (ISBN 978 90 8964 250 9)

#### *IMISCOE Dissertations*

Panos Arion Hatziprokopiou

*Globalisation, Migration and Socio-Economic Change in Contemporary  
Greece: Processes of Social Incorporation of Balkan Immigrants in  
Thessaloniki*

2006 (ISBN 978 90 5356 873 6)

Floris Vermeulen

*The Immigrant Organising Process: Turkish Organisations in Amsterdam and Berlin and Surinamese Organisations in Amsterdam, 1960-2000*  
2006 (ISBN 978 90 5356 875 0)

Anastasia Christou

*Narratives of Place, Culture and Identity: Second-Generation Greek-Americans Return 'Home'*  
2006 (ISBN 978 90 5356 878 1)

Katja Rušinović

*Dynamic Entrepreneurship: First and Second-Generation Immigrant Entrepreneurs in Dutch Cities*  
2006 (ISBN 978 90 5356 972 6)

Ilse van Liempt

*Navigating Borders: Inside Perspectives on the Process of Human Smuggling into the Netherlands*  
2007 (ISBN 978 90 5356 930 6)

Myriam Cherti

*Paradoxes of Social Capital: A Multi-Generational Study of Moroccans in London*  
2008 (ISBN 978 90 5356 032 7)

Marc Helbling

*Practising Citizenship and Heterogeneous Nationhood: Naturalisations in Swiss Municipalities*  
2008 (ISBN 978 90 8964 034 5)

Jérôme Jamin

*L'imaginaire du complot: Discours d'extrême droite en France et aux Etats-Unis*  
2009 (ISBN 978 90 8964 048 2)

Inge Van Nieuwenhuyze

*Getting by in Europe's Urban Labour Markets: Senegambian Migrants' Strategies for Survival, Documentation and Mobility*  
2009 (ISBN 978 90 8964 050 5)

Nayla Moukarbel

*Sri Lankan Housemaids in Lebanon: A Case of 'Symbolic Violence' and 'Every Day Forms of Resistance'*  
2009 (ISBN 978 90 8964 051 2)

John Davies

*'My Name Is Not Natasha': How Albanian Women in France Use Trafficking to Overcome Social Exclusion (1998-2001)*

2009 (ISBN 978 90 5356 707 4)

Dennis Broeders

*Breaking Down Anonymity: Digital Surveillance of Irregular Migrants in Germany and the Netherlands*

2009 (ISBN 978 90 8964 159 5)

Arjen Leerkes

*Illegal Residence and Public Safety in the Netherlands*

2009 (ISBN 978 90 8964 049 9)

Jennifer Leigh McGarrigle

*Understanding Processes of Ethnic Concentration and Dispersal: South Asian Residential Preferences in Glasgow*

2009 (ISBN 978 90 5356 671 8)

João Sardinha

*Immigrant Associations, Integration and Identity: Angolan, Brazilian and Eastern European Communities in Portugal*

2009 (ISBN 978 90 8964 036 9)

Nahikari Irastorza

*Born Entrepreneurs? Immigrant Self-Employment in Spain*

2010 (ISBN 978 90 8964 243 1)

*IMISCOE Textbooks*

Marco Martiniello, Jan Rath, Eds.

*Selected Studies in International Migration and Immigrant Incorporation*

2010 (ISBN 978 90 8964 1601)