

Consumer surplus vs. welfare standard in a political economy model of merger control

Neven, Damien J.; Röller, Lars-Hendrik

Veröffentlichungsversion / Published Version

Arbeitspapier / working paper

Zur Verfügung gestellt in Kooperation mit / provided in cooperation with:

SSG Sozialwissenschaften, USB Köln

Empfohlene Zitierung / Suggested Citation:

Neven, D. J., & Röller, L.-H. (2000). *Consumer surplus vs. welfare standard in a political economy model of merger control*. (Discussion Papers / Wissenschaftszentrum Berlin für Sozialforschung, Forschungsschwerpunkt Marktprozeß und Unternehmensentwicklung, Abteilung Wettbewerbsfähigkeit und industrieller Wandel, 00-15). Berlin: Wissenschaftszentrum Berlin für Sozialforschung gGmbH. <https://nbn-resolving.org/urn:nbn:de:0168-ssoar-116117>

Nutzungsbedingungen:

Dieser Text wird unter einer Deposit-Lizenz (Keine Weiterverbreitung - keine Bearbeitung) zur Verfügung gestellt. Gewährt wird ein nicht exklusives, nicht übertragbares, persönliches und beschränktes Recht auf Nutzung dieses Dokuments. Dieses Dokument ist ausschließlich für den persönlichen, nicht-kommerziellen Gebrauch bestimmt. Auf sämtlichen Kopien dieses Dokuments müssen alle Urheberrechtshinweise und sonstigen Hinweise auf gesetzlichen Schutz beibehalten werden. Sie dürfen dieses Dokument nicht in irgendeiner Weise abändern, noch dürfen Sie dieses Dokument für öffentliche oder kommerzielle Zwecke vervielfältigen, öffentlich ausstellen, aufführen, vertreiben oder anderweitig nutzen.

Mit der Verwendung dieses Dokuments erkennen Sie die Nutzungsbedingungen an.

Terms of use:

This document is made available under Deposit Licence (No Redistribution - no modifications). We grant a non-exclusive, non-transferable, individual and limited right to using this document. This document is solely intended for your personal, non-commercial use. All of the copies of this documents must retain all copyright information and other information regarding legal protection. You are not allowed to alter this document in any way, to copy it for public or commercial purposes, to exhibit the document in public, to perform, distribute or otherwise use the document in public.

By using this particular document, you accept the above-stated conditions of use.



WISSENSCHAFTSZENTRUM BERLIN
FÜR SOZIALFORSCHUNG

SOCIAL SCIENCE RESEARCH
CENTER BERLIN

discussion papers

FS IV 00 - 15

**Consumer Surplus vs. Welfare Standard
in a Political Economy Model of Merger Control**

Damien J. Neven*
Lars-Hendrik Röller**

* University of Lausanne

** Wissenschaftszentrum Berlin für Sozialforschung

October 2000

ISSN Nr. 0722 - 6748

**Forschungsschwerpunkt
Marktprozeß und Unter-
nehmensentwicklung**

**Research Area
Market Processes and
Corporate Development**

Zitierweise/Citation:

Damien J. Neven, Lars-Hendrik Röller, **Consumer Surplus vs. Welfare Standard in a Political Economy Model of Merger Control**, Discussion Paper FS IV 00-15, Wissenschaftszentrum Berlin, 2000.

Wissenschaftszentrum Berlin für Sozialforschung gGmbH,
Reichpietschufer 50, 10785 Berlin, Tel. (030) 2 54 91 - 0

ABSTRACT

Consumer Surplus vs. Welfare Standard in a Political Economy Model of Merger Control

by Damien J. Neven and Lars-Hendrik Röller*

This paper considers merger control in a common agency framework where firms and their competitors can influence the antitrust agency and where transparency – while making lobbying less effective – also implies real resource costs. We examine the performance of two alternative standards that can be assigned to the antitrust agency in the presence of these regulatory failures. We find that under a welfare standard, lobbying leads to the clearance of relatively inefficient mergers that decrease welfare (i. e. there is a type II error). By contrast, under a consumer surplus standard, the agency will ban relatively efficient mergers that would increase welfare (i. e. there is a type I error). Lobbying actually reduces the extent to which this occurs, albeit at a cost in terms of real resources. We also find that a consumer surplus standard is more attractive when mergers are large, when increasing the size of a merger greatly enhances industry profits, when there is little transparency, and when co-ordination costs amongst competitors are low.

ZUSAMMENFASSUNG

Konsumentenrente vs. Wohlfahrtskriterium in einem polit-ökonomischen Modell der Fusionskontrolle

In diesem Beitrag wird die wettbewerbsrechtliche Analyse der Fusionskontrolle mit einem Agency-Ansatz erweitert, in dem Unternehmen die Kartellbehörde beeinflussen können und wo Lobbying Kosten verursacht. Es werden zwei unterschiedliche Entscheidungskriterien der Fusionsbehörde hinsichtlich ihrer Effizienz untersucht. Benutzt die Fusionsbehörde ein Wohlfahrtskriterium führt Lobbying seitens der Unternehmen zur Genehmigung von ineffiziente Fusionen, was zu einem Sinken der Wohlfahrt führt. Andererseits führt das Kriterium der Konsumentenrente zur Untersagung von verhältnismäßig effiziente Fusionen, was die Wohlfahrt ebenfalls reduziert. Daraus ergibt sich, daß eine Berücksichtigung der Anreizstrukturen der Unternehmen die Wettbewerbsbehörde zu beeinflussen, wohlfahrtstheoretisch keine eindeutige Betrachtungsweise zuläßt. In diesem Sinne zeigt sich, daß das Kriterium der Konsumentenrente vorteilhafter ist, bei Mega-Fusionen, wenn Fusionen sehr profitable sind, wenn es wenig Transparenz gibt und wenn die Koordinationskosten zwischen den nicht-fusionierenden Unternehmen niedrig sind.

* We would like to thank seminar participants at the Graduate Institute of International Studies (Geneva) and the 27th EARIE meeting in Lausanne for comments on a previous version of this paper.

1 Introduction

The purpose of this paper is to evaluate alternative objectives that can be assigned to an antitrust agency in charge of merger control. It is striking that some of the major antitrust agencies actually operate with objectives that differ from welfare maximisation. For instance, Art. 2 of the merger regulation stipulates that the merger task force should be solely concerned about restrictions of competition and that efficiency benefits should only be taken into account in so far as consumers are not hurt. Hence, it would appear that the merger regulation is concerned about consumer surplus and not aggregate welfare. The US antitrust legislation has a similar bias in favour of consumers (see e.g. Gellhorn and Kovacic, 1994).

In a world with no regulatory failures, excluding firms' profits from the objectives assigned to the antitrust authority would seem hard to justify on efficiency grounds. However, in the presence of regulatory failures a systematic bias in favour of a particular interest may occur. In this context, it may be desirable for the public authority (the ultimate principal) to manipulate the objective function of the antitrust agency so as to compensate for the bias *ex ante*. For instance, an explicit emphasis on consumer surplus, possibly a full truncation of the objective of the antitrust agency so that profits are ignored, may be appropriate. That is, decisions taken according to a consumer surplus standard may actually lead to higher welfare than those taken according to a welfare standard.

This paper considers the regulatory failures associated with the influences that can be brought to bear on an antitrust agency in charge of merger control¹. We consider a common agency framework (à la Bernheim and Whinston, 1986) in which interested parties can provide inducements to the antitrust agency which are contingent on the outcome of the merger review. We characterise the contingent perks that firms will provide and the decisions that will be taken by the antitrust agency for a distribution of possible mergers and for alternative objectives that can be assigned to the agency. We then compare the advantages and drawbacks of alternative objectives.

In particular, we consider a model with four stages. In the first stage, the government decides on the objective that it will assign to the antitrust agency. We focus on two alternative objectives, namely welfare and consumer surplus².

¹Besanko and Spulber (1993) consider a model where regulatory failures arise from asymmetric information regarding the characteristics of the merger, known by the merging firms but not the antitrust agency. They also evaluate alternative objective functions that the government might assign to the antitrust agency. They find that the optimal rule should give more weight to consumer surplus than profits.

²We focus on these polar cases (rather than consider a continuum of objective functions characterised

In the second stage, a merger is notified and the interested parties provide contingent bids. We consider three interested parties, namely consumers, the merging firms and their competitors. However, we assume that consumers are unable to lobby the antitrust agency. This may arise for at least two reasons. First, consumers may not be well informed about the consequences of proposed mergers and accordingly may not be able to formulate appropriate contingent bids. Second, consumers may face prohibitive transaction costs in representing their interests. These costs could be associated with the traditional problems of free-riding and collective action with numerous agents. The assumption that consumers are underrepresented in merger review also seems to be broadly consistent with casual observation (for instance, consumer organisations are seldom represented in merger hearings).

In the third stage, the antitrust agency (the common agent) decides whether or not to allow the proposed mergers on the basis of its assigned objective and the contingent perks by the interested parties (the principals). In line with the literature on political economy interactions in a common agency framework (see for instance Grossman and Helpman, 1994), we do not explicitly model how the actions of the antitrust agency could be monitored by the government. Rather, we simply assume that the agency is subject to imperfect accountability and can compromise the pursuit of its mission while responding to perks. Unlike the previous literature, we explicitly consider the effect of accountability. In particular, when the agency is accountable, only a fraction of what firms spend in lobbying will affect the agency's behaviour, so that with greater accountability the agency will be more difficult to influence. Moreover, we assume that the share of firms' bid which does not affect the agency's behaviour is pure social waste. This assumption is meant to represent the fact that with greater transparency influence has to take indirect routes which are typically less efficient than a direct transfer. For instance, when bribes can be monitored by the government, influences will take place through indirect means like expensive lunches or the promise of lucrative jobs in the private sectors (the "revolving door"). Whereas pure transfers do not entail any efficiency losses, indirect means of influencing the agency typically involve some real resource cost. Hence, while greater transparency polices the behaviour of the agency, it also involves some real resource costs. We also assume that lobbying by competitors is relatively less efficient than lobbying by merging firms simply because competitors are more numerous and hence incur some co-ordination cost. As a result we allow for co-ordination costs amongst competitors that are increasing in the number of competing firms.

In the final stage, product market competition takes place. In equilibrium, firms will thus provide perks anticipating the decision taken by the antitrust agency and the

by different weights for profits) because intermediate cases are presumably hard to implement in practice.

profits that will accrue from the outcome of this decision.

The profits that merging firms and their competitors anticipate as a result of any particular merger configuration are determined by market interactions before and after the merger. For our purposes, we do not need to specify the market game explicitly, but rather make some general monotonicity assumptions on the reduced form profit function of the merging firms and their competitors, as well as consumer surplus. In particular, we assume that the profits of the merging firms, the consumer surplus and welfare increase monotonically with the efficiency gains achieved by the merger, while the profits of competitors decrease monotonically. These assumptions are reasonable and hold for Cournot with homogenous products. We also assume that larger mergers always enhance industry profits but reduce welfare.

For both of the agency's objective functions (i.e. welfare and consumer surplus), we characterise the equilibrium and the associated welfare (ex post) for a range of possible mergers characterised by different efficiency levels. We find that under a welfare standard the agency will allow relatively inefficient mergers that decreases welfare (there is a type II error). In those circumstances, there is also some social waste associated with lobbying by the merging firms and their competitors. By contrast, when the agency operates with a consumer surplus standard, it will ban relatively efficient mergers that would increase welfare (there is a type I error). In addition, there is range of mergers which display even higher efficiency which are only allowed because of lobbying. In those circumstances, there is some social waste associated with lobbying but no decision error. Overall, lobbying still appears to be desirable under a consumer surplus standard because lobbying re-balances the objective function of the antitrust agency in favour of firms. Looking at the relative costs and benefits of the alternative standards, we observe that a consumer surplus standard is more attractive when mergers are large, when increasing the size of a merger greatly enhances industry profits, and when transparency and co-ordination costs are low.

We present the model in Section 2 and derive the equilibrium in Section 3. The comparative statics with respect to the size of the merger and transparency is presented in Section 4. Section 5 concludes.

2 The model

We consider an industry with N firms. A merger in this industry is characterised by the number of firms involved, M , and by the level of efficiency, e , which is achieved by the merged entity. This parameter can be thought of as the reduction of the marginal cost accruing to the merging firms.

The structure of the game is illustrated in Figure 1. In stage 1 the government assigns a standard to the antitrust agency. It can choose either a welfare standard or a consumer surplus standard. The objective function of the government is the change in total welfare (profits and consumer surplus) less the waste associated with the lobbying process:

$$W = \Pi_m + \Pi_c + CS - (1 - \alpha)F_m - (1 - \alpha + \varepsilon(N - M))F_c \quad (1)$$

where Π_m is the *change* in aggregate profits accruing to the merging firms, Π_c is the *change* in aggregate profits to the competing firms, CS is the *change* in consumer surplus, F_m and F_c are the combined bids of the merging parties and the competing firms to the agency, respectively. Note that if the merger is banned, the change in profits and consumer surplus is simply zero.

We assume that the process of lobbying involves two types of inefficiencies. First, a fraction $(1 - \alpha)$ of the bids paid by the merging firms and its competitors are wasted. As discussed above, a high share of waste corresponds to an environment with high transparency so that firms have to resort to indirect and inefficient means of influencing the government. Second, we also assume that lobbying by competitors is relatively less efficient than lobbying by merging firms simply because competitors are more numerous and hence incur some co-ordination cost. The waste associated with co-ordination is captured by the term $\varepsilon(N - M)$, where we assume that the co-ordination costs are increasing in the number of competing firms³ $N - M$, i.e. $\varepsilon'(N - M) > 0$. Let us also denote $\beta = \alpha - \varepsilon(N - M)$ as the share of the bid paid by the competitors which is pure waste.

In stage 2, firms provide contingent bids to the agency. The objective function of the firms are the changes in their net profit, namely the change in their profit (as defined above) minus the bids that they provide to the agency.

In stage 3, the agency decides whether to allow the merger or not. The agency takes into account the standard set by the government and the bids by firms. Whenever the agency has been given a welfare standard by the government, its objective functions is given by,

$$U_1 = \Pi_m + \Pi_c + CS + \alpha F_m + (\alpha - \varepsilon(N - M))F_c \quad (2)$$

³Note that in this specification the merging firms do not incur any co-ordination costs

In other words, the agency maximises the sum of the change in welfare associated with the merger and the effective bids (the share of the bid which is not wasted). As discussed above, we assume that consumers cannot lobby.

Alternatively, whenever the agency is endowed with a consumer surplus standard, its objective function is given by,

$$U_2 = CS + \alpha F_m + (\alpha - \varepsilon(N - M))F_c \quad (3)$$

In stage 4, firms compete and profits and bids are realised.

3 The equilibrium

We look for a perfect equilibrium and solve the model by backward induction. Hence, we first consider the equilibrium in stage 4 where firms compete.

3.1 Product market competition in stage 4.

Let Π_m^* denote the change in aggregate gross equilibrium profits of the merging firms and Π_c^* denote the change in aggregate gross equilibrium profits of the competitors (that is the profits before bids are deducted), if the merger is realised. If the merger is not allowed, gross profits are unaffected so that the changes in gross profits are zero.

We do not explicitly specify the market game but assume that the following properties of the profit functions as well as consumer surplus hold in equilibrium⁴:

$$\text{A1: } \frac{\partial \Pi_m^*}{\partial e} > 0, \frac{\partial \Pi_c^*}{\partial e} < 0, \frac{\partial (\Pi_m^* + \Pi_c^*)}{\partial e} > 0$$

$$\text{A2: } \frac{\partial CS}{\partial e} > 0$$

$$\text{A3: } \frac{\partial (\Pi_m^* + \Pi_c^* + CS^*)}{\partial M} < 0$$

$$\text{A2: } \frac{\partial (\Pi_m^* + \Pi_c^*)}{\partial M} > 0$$

Hence, we assume that the profitability of a merger increases with the level of efficiency that it can achieve. The profits of competitors fall with this level of efficiency but the industry profit still rises. We also assume that as the efficiency gains increase, the equilibrium price falls so that the consumer surplus increases. These assumptions imply that welfare increases in line with the efficiency gain. It is straightforward but tedious to check that these properties actually hold for a Cournot model with homogenous products.

⁴We also assume that they are continuous and differentiable.

The last two assumptions restrict our analysis to situations where larger mergers increase industry profits and reduce welfare. These assumptions accord with intuition and should hold for a wide variety of market models.

Beyond our maintained assumptions about the profit function A1-A4, we further assume that the competitors (whose profit fall with efficiency) and the consumers (whose surplus increase with efficiency) are indifferent for an identical value of the efficiency gain denoted by e' . In other words, $\exists e' > 0$, s.t. $\Pi_c^*(e') = CS^*(e') = 0$. This property does not appear to be unduly restrictive since it accords with intuition that when the equilibrium price is unaffected by the merger, competitors should also be unaffected. Again, one can check that this property actually holds for a Cournot model with homogenous products (see Bond, 1994). Finally, we assume the merging parties are rational and restrict attention to the range of efficiency parameters which ensure that mergers are profitable (i.e. such that $\Pi_m^* > 0$).

The impact that a merger has on the interests of merging firms, competitors and consumers under these assumptions is presented graphically in Figure 2, as a function of the efficiency achieved by the merger (holding constant the number of firms as well as the number of merging firms). Note that consumers and the competing firms never have congruent interests. When efficiency is such that the price increases after the merger, the interests of the merging firms and their competitors are aligned. By contrast, when efficiency is large enough to guarantee that the price falls, the merging firms benefit from the mergers and become the allies of consumers, against the interest of competitors.

For further reference, it is also useful to define the efficiency level which guarantees that the change in total welfare is unaffected by the merger. Denote the change in welfare at a given efficiency gain by $\tilde{S}^*(e) = \Pi_c^*(e) + \Pi_m^*(e) + CS^*(e)$. Note that by A1 and A2 $\tilde{S}^*(e)$ is increasing in e . Define the efficiency level at which total welfare is unchanged by the merger as \tilde{e} such that $\tilde{S}^*(\tilde{e}) = 0$ (see also Figure 2).

Note that the change in welfare at e' is positive, since $\Pi_c^*(e') = CS^*(e') = 0$ and $\Pi_m^*(e') > 0$. The last inequality holds, since at an efficiency level of e' , price and output are unaffected by the merger. Total revenues are thus unaffected but total costs fall in line with the efficiency gain so that the change in profits has to be positive. Furthermore, given the monotonicity of welfare (through A1 and A2), we also have that $\tilde{e} < e'$.

Our assumptions with respect to the size of the merger (A3 and A4) can also be illustrated in Figure 2. A4 implies that the sum of firms' profits is shifted upwards for larger mergers. By A3, consumer surplus is shifted downwards and the efficiency level for which welfare is unaffected (\tilde{e}) moves to the right.

3.2 Decisions by the antitrust authority in stage 3

In stage 3 the agency decides on the merger. The decision of the authority is either to ban ($D = 0$) or to allow ($D = 1$) the merger (no remedies are allowed). In order to avoid unessential complexities, we assume that if the agency is indifferent between allowing and prohibiting a merger, it will decide to allow it. The equilibrium at this stage is straightforward: the agency simply compares the levels of utility that it achieves under each outcome and selects the outcome that yields the highest level.

Formally, the equilibrium is described as follows. Consider first the welfare standard. In this case, the agencies utility if they allow the merger is given by (2), i.e. $U_1(D = 1) = \Pi_m^* + \Pi_c^* + CS^* + \alpha F_m(D = 1) + (\alpha - \varepsilon(N - M))F_c(D = 1)$. Similarly, the utility if the agency blocks the merger is given by $U_1(D = 0) = \alpha F_m(D = 0) + (\alpha - \varepsilon(N - M))F_c(D = 0)$. For the consumer surplus standard, the agencies utility if they allow the merger is given by (3), i.e. $U_2(D = 1) = CS^* + \alpha F_m(D = 1) + (\alpha - \varepsilon(N - M))F_c(D = 1)$, while the utility if the agency blocks the merger is given by $U_2(D = 0) = \alpha F_m(D = 0) + (\alpha - \varepsilon(N - M))F_c(D = 0)$. Therefore, the decision by the agency is characterized by,

$$D = \left\{ \begin{array}{l} 1 \text{ if } U_i(D = 1) \geq U_i(D = 0) \\ 0 \text{ otherwise} \end{array} \right\}$$

where $i = 1, 2$ indicates the welfare and consumer standard respectively.

3.3 Lobbying decisions at Stage 2

We derive equilibrium bids for both welfare and consumer surplus standards. Note that the bids are contingent on the actions of the antitrust agency. We therefore need to consider firms' incentives to bid against and in favor of the merger being allowed. We begin with the welfare standard.

3.3.1 Welfare standard

Assume that the agency is assigned the welfare standard. In order to solve for the equilibrium bids, it is convenient to distinguish among various parameter regions with respect to the efficiency level. As noted above, when $e < e'$, both the merging firms and their competitors benefit from the merger and hence will never bid to influence the antitrust authority against the merger. We therefore have $F_m(D = 0) = F_c(D = 0) = 0$.

We first consider the firms' incentives to bid in favor of the merger for regions $e \leq e'$. Consider the region where $\tilde{e} \leq e \leq e'$. This is the range of efficiency for which mergers do not increase the consumer surplus but do not reduce welfare.

Lemma 1 *Let $\tilde{e} \leq e \leq e'$. Firms will not bid and the merger is allowed.*

Proof: The agency will allow the merger without any bids, since $U_1(D = 1) = \Pi_m^* + \Pi_c^* + CS^* \geq U_1(D = 0) = 0$. Therefore in equilibrium firms will not bid. Q.E.D.

In this region, the efficiency of the merger is such that welfare does not fall. Hence, firms do not have to bid in order to influence the antitrust agency, which allows the merger without any inducement.

Let us now focus on efficiency level below \tilde{e} . In this region, the change in welfare is negative and firms (which benefit from the merger) will have to provide incentive to the agency if they want the merger to be allowed. Given the decision of the agency in stage 3, firms will have to ensure that $U_1(D = 1) \geq 0$. Consider the highest amount that firms can bid, i.e. their entire profit. The resulting value of the utility of the agency if the merger is allowed is then given by $S_1^*(e) = \Pi_m^* + \Pi_c^* + CS^* + \alpha\Pi_m^* + (\alpha - \varepsilon(N - M))\Pi_c^*$. Let e_1^* be the efficiency level such that $S_1^*(e_1^*) = 0$.

Lemma 2 *For $e < e_1^*$, firms will not bid and the merger is blocked. For $e_1^* \leq e < \tilde{e}$, firms bid such that $U_1(D = 1) = 0$ and the merger is allowed.*

Proof : Note that $S_1^*(e)$ is monotonically increasing and continuous in e by A1 and A2. Since $S_1^*(\tilde{e}) > 0$, we have that $e_1^* < \tilde{e}$ and that e_1^* is unique and it exists (assuming that $S_1^*(e) < 0$ for some possibly negative e). Let $e < e_1^*$ such that $S_1^*(e) < 0$, which implies that $U_1(D = 1) < 0$ for the maximum bids. Therefore, the merger is blocked and it is optimal for firms not to bid. Let $e_1^* < e < \tilde{e}$, which implies that $S_1^*(e) > 0$. Any pair of bids $F_m(D = 1), F_c(D = 1)$ such that $U_1(D = 1) = 0$ is an equilibrium. The merger is allowed. Q.E.D.

Hence, whenever efficiency is insufficient to guarantee that the merger will increase welfare, firms have to provide incentives to the agency in order to have the merger waved through. However, the profit of the merging firms and its competitors increase in line with the level of efficiency. There is thus a range of efficiency parameter (below that which guarantees no change in welfare) for which firms have sufficient profit to provide adequate incentives to the antitrust agency. In this region, we consequently have two types of inefficiencies, which occur simultaneously. The first one arises because the merger is pushed through by the lobbying activity of firms, even though it reduces welfare. We therefore have a type II error. In addition, there is bidding in equilibrium and this entails some waste.

It is worth noting at this point that the agency does not obtain any rent from the political economy interactions because firms always provide just enough incentives to make the antitrust agency indifferent between allowing and prohibiting the merger. It is

indeed a standard feature of equilibrium in common agency games that the agent obtains positive rents from the interactions only if the principals have divergent interests (see for instance Grossman and Helpman, 1994).

We now consider the region where the incentives of the firms are not aligned, i.e. when e is above e' .

Lemma 3 *For $e > e'$, the merger is allowed. In equilibrium the merging firms bid $F_m(D = 1) = \max\{0, -\beta\Pi_c^* - (\Pi_m^* + \Pi_c^* + CS^*)\}$.*

Proof : Given that competitors are hurt by the merger we must have that $F_c(D = 1) = 0$, which implies that the agency will allow the merger when $U_1(D = 1) = \Pi_m^* + \Pi_c^* + CS^* + \alpha F_m(D = 1) \geq U_1(D = 0) = \beta F_c(D = 0)$. Note that by A1, we have that $\Pi_m^* > -\Pi_c^*$, which implies that in equilibrium $F_m(D = 1) < \Pi_m^*$, i.e. the merging firms are always able to push the merger through. Assume that $\Pi_m^* + \Pi_c^* + CS^* < -\beta\Pi_c^*$ so that competitors could have the merger prohibited in the absence of bid by the merging firms. $F_m(D = 1) = -\beta\Pi_c^* - (\Pi_m^* + \Pi_c^* + CS^*)$ is then a best reply to $F_c(D = 0) = -\beta\Pi_c^*$. $F_c(D = 0) = -\beta\Pi_c^*$ is a (weak) best reply to $F_m(D = 1) = -\beta\Pi_c^* - (\Pi_m^* + \Pi_c^* + CS^*)$. In equilibrium, the maximum bid of the competing firms is neutralized by the merging firms. Next, assume that $\Pi_m^* + \Pi_c^* + CS^* > -\beta\Pi_c^*$. Then $F_m(D = 1) = 0$ is an equilibrium since the maximum bid of the competing firms can not block the merger. Furthermore, any contingent bid by competitors $F_c(D = 0)$ is a best reply. Q.E.D.

In this region, the level of efficiency is such that competitors are harmed by the merger and would want to influence the antitrust agency to block it. We therefore have opposing interests on the part of the firms. In principle, the competitors might lose more from the mergers than what the merger entails in terms of welfare gains, i.e. is possible that $\Pi_m^* + \Pi_c^* + CS^* < -\beta\Pi_c^*$. In this case, where "competitors are badly hurt" by a merger, they are capable to compensate the agency for the loss of welfare that would arise if the merger is prohibited. However, as the above lemma shows, the merging firms are always able to neutralize the bids by the competitors, which implies that the merger will always go through. The agency does not make an error but there is a social cost associated with lobbying. When the maximum bid of the competitors could not overturn the merger even if the merging firms do not bid ($\Pi_m^* + \Pi_c^* + CS^* < -\beta\Pi_c^*$), the merging firms do not bid and there is no waste.

In sum, we find that relative to the adjacent parameter range (i.e. to the left of e'), the emergence of opposing interests among firms does not change the outcome of the merger decision, but may introduce lobbying activity, and hence some an inefficiency. When there is no interest which dominates, the merging firms, which can always trump

the competitors, has to lobby. In this case, the agency obtains some rent from the political economy interaction.

We now turn to the alternative standard.

3.3.2 Consumer surplus standard

Assume that the agency is assigned the consumer surplus standard. As before, we first focus on the parameter region for which firms incentives are aligned ($e \leq e'$), such that $F_m(D = 0) = F_c(D = 0) = 0$. We first consider the region such that $e \leq \tilde{e}$, i.e. where efficiency is not sufficient to guarantee that the change in welfare is positive.

Lemma 4 *Let $e \leq \tilde{e}$. Firms will not bid and the merger is blocked.*

Proof: The agency will allow the merger iff $U_2(D = 1) = CS^* + \alpha F_m(D = 1) + (\alpha - \varepsilon(N - M))F_c(D = 1) \geq 0$. This can not hold since $\Pi_c^*(e) + \Pi_m^*(e) + CS^*(e) \leq 0$ for $e \leq \tilde{e}$. The merger is blocked and it is optimal for firms not to bid. Q.E.D.

In this region, both the change in consumer surplus and welfare are non-positive. Hence, firms do not have sufficient resources to compensate the antitrust agency for the loss of consumers surplus that a merger would entail. As a result, firms do not bid and the merger is prohibited.

Let us now focus on efficiency level above \tilde{e} , such that $\tilde{e} < e < e'$. In this region, the change in consumers surplus is still negative and firms might be able to provide enough incentive to the agency in order to get the merger approved. Given the decision of the agency in stage 3, firms will have to ensure that $U_2(D = 1) \geq 0$. Consider the highest amount that firms can bid, i.e. their entire profit. The resulting value of the utility of the agency if the merger is allowed is then given by $S_2^*(e) = CS^* + \alpha \Pi_m^* + (\alpha - \varepsilon(N - M))\Pi_c^*$. Let e_2^* be the efficiency level such that $S_2^*(e_2^*) = 0$. Note that $S_2^*(e)$ is continuous and monotonically increasing in e by A1 and A2. Since $S_2^*(\tilde{e}) < 0$ and $S_2^*(e') > 0$ it follows that $\tilde{e} < e_2^* < e'$ and that it is unique.

Lemma 5 *For $\tilde{e} < e < e_2^*$ firms do not bid and the merger is blocked. For $e_2^* \leq e < e'$ firms bid such that $U_2(D = 1) = 0$ and the merger is allowed.*

Proof : Let $\tilde{e} < e < e_2^*$. In this case, $S_2^*(e) < 0$, which implies that the merger is blocked even if firms bid their entire profits. Hence, firms will not bid and the merger is blocked. Let $e_2^* \leq e < e'$, which implies that $S_2^*(e) \geq 0$. Any pair of bids such that $F_m(D = 1), F_c(D = 1)$ such that $U_2(D = 1) = 0$ is an equilibrium. The merger is allowed. Q.E.D.

As efficiency increases beyond the level at which welfare is unchanged, profits increase and the harm to consumers falls. There is a region ($\tilde{e} < e < e_2^*$) for which the profits are still insufficient to provide adequate incentives to the antitrust agency and the merger is prohibited even though it would increase welfare. In this region, there is a type I error but no social waste associated with lobbying. Beyond this level of efficiency ($e_2^* \leq e < e'$), the merger is allowed but only because firms provide adequate inducement, which involve some social waste. As the efficiency level approaches the level for which consumer surplus is unaffected, the bids and hence the social waste converge to zero.

We now consider the region where the firms' incentives are not aligned, i.e. such that e is above e' .

Lemma 6 *For $e \geq e'$, the merger is allowed. The merging firms bid $F_m(D = 1) = \max\{0, -\beta\Pi_c^* - CS^*\}$*

Proof : See proof of Lemma 3, which applies mutatis mutandis.

In this region, the level of efficiency is such that competitors are harmed by the merger and would want to influence the antitrust agency to block the merger. In the case where "competitors are badly hurt" by a merger ($CS^* < -\beta\Pi_c^*$), they are capable to compensate the agency for the loss in consumer surplus that would arise if the merger is prohibited. In this case, the merging firms, which can always trump the competitors, need to compensate for the maximum bid that competitors can lodge. The agency make no error in its decision but lobbying leads to social waste and some rent for the antitrust agency. When the maximum bid of competitors cannot compensate for the change in consumer surplus, the merging firms do not need to bid and there is no waste

In sum, we find (as in the case of the welfare standard) that the merger is allowed despite opposing interest. Under the consumer surplus standard, the merger is pushed through, to the left of e' , by a joint action of the mergers firms and their competitors. To the right, the merger might be pushed through again by the action by the merging firms which compensate for that of the competitors. When lobbying is taking place, some inefficiency will also arise. Comparing the condition in Lemma 6 with Lemma 3, we find that the condition for a "wasteful" equilibrium to exist is stricter for the welfare standard. This implies that there exist parameter regions for which equilibrium under the welfare standard does not involve any bidding, while the equilibrium under the consumer surplus standard does involve bidding (and therefore waste). The reverse is not true. In addition, the bid of the merging firms under the consumer surplus standard ($F_m(D = 1) = -\beta\Pi_c^* - CS^*$) is always higher than the bid under the welfare standard ($F_m(D = 1) = -\beta\Pi_c - (\Pi_m^* + \Pi_c^* + CS^*)$).

3.3.3 The choice of standard in stage 1

At this stage, the government decides on the welfare standard in order to maximise (1). Denote W_1 and W_2 as the equilibrium level of the government's objective function under the welfare standard and consumer surplus standard respectively. In order to provide a benchmark, we also define the maximum level of the government's objective function that could be achieved for any e , i.e. the first best denoted by \hat{W} . Under the first best, the social planner would set waste to zero, which implies no bidding by the firms. For $e < \tilde{e}$, the merger will be banned so that $\hat{W} = 0$. For $e \geq \tilde{e}$, mergers will be allowed so that $\hat{W} = \Pi_m^* + \Pi_c^* + CS^*$.

The next two lemmas characterize the government's objective function under the welfare and consumer surplus standards. Given the results of Lemma 3 and 6, we will assume that $CS^* > -\beta\Pi_c^*$, which ensures that firms will not bid when $e > e'$ under either standard.

Lemma 7 *The government's objective function under the welfare standard is given by*

$$W_1 = \begin{pmatrix} 0 & \text{if } e < e_1^* \\ -(F_m + F_c) & \text{if } e_1^* \leq e < \tilde{e} \\ \Pi_m^* + \Pi_c^* + CS^* & \text{if } \tilde{e} \leq e \end{pmatrix}$$

Proof : The first and third statements follow directly from respectively Lemma 2 and Lemma 1. Consider the second statement; from Lemma 2, it follows that in equilibrium $\Pi_m^* + \Pi_c^* + CS^* = \alpha F_m(D = 1) + (\alpha - \varepsilon(N - M))F_c(D = 1)$. Using this equality to evaluate (1), the result follows directly. Q.E.D.

Lemma 8 *The government's objective function under the consumer surplus standard is*

$$\text{given by } W_2 = \begin{pmatrix} 0 & \text{if } e < e_2^* \\ \Pi_m^* + \Pi_c^* - F_m - F_c & \text{if } e_2^* \leq e < e' \\ \Pi_m^* + \Pi_c^* + CS^* & \text{if } e' \leq e \end{pmatrix}$$

Proof : Follows directly from Lemmata 4 and 5, using (1). Q.E.D.

The previous results are further illustrated in Figure 3 which represents the difference in the objective function of the government under the two rules, i.e. $W_1 - W_2$. When efficiency gains are very small (i.e. $e < e_1^*$), the merger is always banned, no bids are put forward, the two standards are equivalent and yield the first best (i.e. $\hat{W} = W_1 = W_2 = 0$).

When $e_1^* \leq e < \tilde{e}$, mergers are still prevented under the consumer surplus standard, no bids are put forward and the first best is achieved ($\hat{W} = W_2 = 0$). By contrast, under

the welfare standard, firms bid and the merger is allowed. This introduces two types of inefficiencies: (i) the merger is allowed even though it yields a negative welfare, so that there is a type II error, and (ii) there is waste associated with the bids. The sum of the two inefficiencies add up to the value of the bids (so that $W_1 - W_2 = -(F_m + F_c)$). The reason is that the effective value of the bid (the part which is not wasted) has to compensate exactly for the loss of welfare in equilibrium. The inefficiency, which is the loss of welfare and the wasted part of the bids, is thus equal to the bids. Furthermore, the magnitude of the bids falls as the efficiency gains of the merger increase (see Figure 3). At $e = \tilde{e}$, firms do not need to bid any longer since the merger does not decrease welfare.

When $\tilde{e} \leq e < e_2^*$, under the welfare standard firms do not bid and the merger is allowed so that the first best is achieved ($W_1 = \hat{W} = \Pi_m^* + \Pi_c^* + CS^*$). Under the consumer surplus standard, the merger is blocked but firms do not put forward any bid. There is thus a type I error: a merger which increases welfare is blocked and $W_1 - W_2 = \Pi_m^* + \Pi_c^* + CS^*$. Given that welfare increases in e , the opportunity cost of not allowing the merger increases as the efficiency gain rises (see Figure 3).

When $e_2^* \leq e < e'$, under the welfare standard, the first best is achieved. Under the consumer surplus standard, firms bid and the merger is allowed. There is no type I error but there is waste associated with bidding, such that $W_1 - W_2 = (1 - \alpha)F_m + (1 - \alpha + \varepsilon(N - M))F_c$. Note that for $e = e_2^*$, the entire profit is bid and the proportion of the profit which is not wasted is equal to the loss in consumer surplus. Therefore, the change in welfare at e_2^* is equal to zero. As a result $W_1 - W_2$ is continuous at $e = e_2^*$. Moreover, as efficiency gains increase, the waste in bidding falls (down to 0 at e').

Overall, it appears that neither standard dominates over the entire range of parameters, even though one of the two standards is always first best for any given efficiency level. Consumer surplus and welfare standard give rise to different types of costs depending on the efficiency level. On the one hand, a number of relatively inefficient mergers – which decrease welfare – are pushed through under a welfare standard. On the other hand, some relatively efficient mergers (which would increase welfare) are prohibited under the consumer surplus standard. This result accord with intuition; when the agency is supposed to consider welfare but firms can influence the agency, one would indeed expect the outcome to be biased in favour of firms and against consumers. With a welfare standard, lobbying activity thus lowers welfare.⁵

⁵Note however that if all interests were equally represented and equally efficient in their lobbying, the welfare standard would not give rise to any error. It is a standard feature of common agency games that when the agent has a welfare standard and the principals bid their marginal benefit, the agent mimics the behaviour of an independent agent which would simply maximise welfare (see for instance

By contrast, when the agency defends consumers interest, it will be biased against the interest of firms and tend to prohibit mergers that enhance welfare. Firms' lobbying activity will tend to compensate for the narrow objective of the agency and thereby reduce the range of relatively efficient mergers that are prohibited. Without lobbying, all mergers in between \tilde{e} and e' would be prohibited with a loss in welfare equal to $\Pi_m^* + \Pi_c^* + CS^*$. With lobbying, the welfare loss is strictly smaller for the region between e_2^* and e' (see Figure 3). Under the consumer surplus standard, lobbying thus strictly improves welfare.

A comparison between the two standards over the entire range of parameters can also be undertaken. However, such a comparison requires an explicit assumption about the distribution of mergers that the agency will face in terms of their efficiency level. This distribution is also likely to have a strong influence on the eventual outcome of the comparison. For instance, it is likely that if the expected population of mergers is biased in favour of very efficient mergers, the consumer surplus standard will dominate. At the opposite, if the distribution of expected mergers features a high density of rather inefficient mergers, it is likely that a consumer surplus standard will be preferred. In addition, an explicit comparison of the two standards would require a specific assumption about the distribution of lobbying efforts between merging firms and their competitors (given that action by the latter is less efficient than action by the former). Again, this assumption might matter a great deal for the outcome of the comparison and would be somewhat arbitrary. Hence, rather than make explicit assumptions about the distribution of expected mergers and the allocation of lobbying effort and derive an explicit comparison between the two standard, we focus on comparative statics. In particular, we next examine how the comparison between the two standards would be affected by a change in the efficiency of the lobbying process and a change in the size of the mergers.

Grossman and Helpman, 1994). Hence, if consumers had equally efficient access to the antitrust agency, all welfare enhancing mergers would be allowed in our model and all welfare decreasing mergers would be prohibited. However, the first best would still not be obtained as a potentially large amount of waste would occur because of lobbying. In addition, if the merging firms, the competitors and consumers were not equally efficient in lobbying or if lobbying entailed some fixed cost, the equilibrium under the welfare standard would entail some errors.

4 The trade-off between welfare and consumer surplus standards

Let us first characterise the trade-off between the two standards with respect to the efficiency of the lobbying process. As discussed above, more transparency in the operation of the anti-trust agency will tend to increase the amount of resources which is wasted in lobbying. In the context of our model, a more efficient process of lobbying is thus associated with less transparency. An increase in α or a decrease in ε are associated with a more efficient process of lobbying.

We first characterise (Proposition 1) how the various parameter regions are affected by a change in α and ε . A full comparison between the two standards, however, needs to consider how the absolute levels of the government's objective function is affected. This will be undertaken in the subsequent proposition.

Proposition 1 *With a more efficient lobbying process, the efficiency region over which the consumer surplus standard (CSS) is dominated is unchanged and the efficiency region over which the CSS dominates increases.*

Proof : By definition of \tilde{e} and e' and by A1 and the monotonicity of $S_1^*(.)$ and $S_2^*(.)$, we have that $\frac{\partial e_1^*}{\partial \alpha} < 0$, $\frac{\partial e_2^*}{\partial \alpha} < 0$, $\frac{\partial \tilde{e}}{\partial \alpha} = \frac{\partial e'}{\partial \alpha} = 0$ and $\frac{\partial e_1^*}{\partial \varepsilon} > 0$, $\frac{\partial e_2^*}{\partial \varepsilon} > 0$, $\frac{\partial \tilde{e}}{\partial \varepsilon} = \frac{\partial e'}{\partial \varepsilon} = 0$. Q.E.D.

Proposition 1 illustrates that a more efficient lobbying process increases the set of parameters for which mergers that decrease welfare are pushed through under a welfare standard (i.e. in between e_1^* and \tilde{e}). This accords with intuition; as a higher share of profit can be used to effectively influence the agency, mergers which require marginally more influence over the agency can now be pushed through.

By contrast, the efficiency of the lobbying process does not affect the range of parameters for which inefficient outcomes occur under a consumer surplus standard, since neither \tilde{e} nor e' are effected by the efficiency of the lobbying process. The reason for this is that the inefficient outcomes near \tilde{e} cannot be pushed through by firms. A marginal increase in efficiency does not change this. Also, in the upper limit of the inefficiency region (near e') only a marginal amount of resources is necessary to push the merger through at this point and more efficient lobbying does not affect the outcome.

Hence, it appears that in terms of parameters ranges, the consumer surplus standard becomes more attractive than the welfare standard as the efficiency of lobbying increases.

The next proposition examines how the value of the government's objective function is affected by more efficient lobbying.

Proposition 2 *In the efficiency region where the CSS is dominated, the net cost of the CSS is reduced for more efficient lobbying process. When the CSS dominates, the effect of a more efficient lobbying process on the net benefit of the CSS is ambiguous.*

Proof: Let us first consider the region $e_2^* \leq e < e'$. The net cost of the CSS using the above Lemmata 7 and 8 is $W_1 - W_2 = (1 - \alpha)F_m + (1 - \alpha + \varepsilon(N - M))F_c$. From the equilibrium conditions in stage 2 (Lemma 5) for any e , $\alpha F_m + (\alpha - \varepsilon(N - M))F_c$ does not change with α (or ε). Hence, when α increases (or ε falls), $F_m + F_c$ falls. Since $(1 - \alpha)$ and $F_m + F_c$ fall in α (increase in ε), it follows that $W_1 - W_2$ falls in α (increases in ε). Consider now the region $\tilde{e} \leq e < e_2^*$. In this region (see Lemmata 7 and 8) we have $W_1 - W_2 = \Pi_m + \Pi_c + CS$, which is independent of α (or ε). Since, $\partial e_2^*/\partial \alpha < 0$ and $\partial e_2^*/\partial \varepsilon > 0$ by Proposition 1, the first part of the proposition follows. For the second part of the proposition consider the region $e_1^* \leq e < \tilde{e}$. We focus on the comparative statics of α . The proof for ε is analogous. By Proposition 1 $\partial e_1^*/\partial \alpha < 0$, so that we first consider $e_1^* + \partial e_1^*/\partial \alpha < e < \tilde{e}$. In this region from Lemmata 7 and 8 we have $W_1 - W_2 = -F_m - F_c$, which is increasing in α by the equilibrium condition in Lemma 2. Since, $\partial e_1^*/\partial \alpha < 0$, there is a new region where the CSS is dominated, i.e. $W_1 - W_2 < 0$. Q.E.D.

The Proposition is illustrated in Figure 4 and offers two useful insights. The first insight relates to the parameter range for which the consumer surplus standard yields an inefficient outcome. As discussed, this parameter range is not affected by the efficiency of lobbying. However, Proposition 2 illustrates that the type of inefficiency that occurs in this range is affected by the efficiency of lobbying: as lobbying becomes more efficient, the range of parameter for which a type I errors occurs shrinks and the range of parameter for which lobbying occurs, and implies some waste, will increase (see Figure 4). In other words, as lobbying becomes more efficient, more resources are available at the margin to influence the antitrust agency and mergers which require marginally more influence can effectively be pushed through. As a result the range of parameters for which a type I error occurs shrinks, and more mergers are pushed through.

In addition, a type I error always entails a higher efficiency loss than lobbying in this parameter range (see Figure 4 again). The waste associated with lobbying is only a fraction of the loss entailed by prohibiting the merger which is the entire opportunity cost of the merger in terms of welfare. Hence, a reduction of type I errors will reduce the cost associated with the consumer surplus standard in this area.

Consequently, there are two reasons as to why the cost associated with the consumer surplus standard falls when lobbying becomes more efficient. First, more efficient lobbying implies that fewer resources are wasted for any efficiency level for which lobbying

occurs. Second, more efficient lobbying also reduces the range of parameters for which a type I error occurs and this reduces the cost of the consumer surplus standard because for any efficiency level, a type I error is more costly than the waste associated with successful lobbying. This result which will be useful for further reference is collected in Lemma 9.

Lemma 9 *In the efficiency region where the CSS is dominated, the net cost of the CSS increases in e_2^* , holding \tilde{e} and e' constant.*

Proof: Follows from Proposition 2.

The second insight offered by Proposition 2 relates to the parameter region where mergers that decrease welfare are pushed through by lobbying under the welfare standard. As discussed above, more efficient lobbying (less transparency) extends the range of mergers for which a type II error occurs under the welfare standard. At the same time, for any value of the efficiency parameter for which the merger is pushed through, less resources are wasted in influencing the government (see Figure 4). As a result the impact of more efficient lobbying is ambiguous. This trade-off also illustrates the effect of transparency. On the one hand, transparency is desirable because it will reduce the scope of undesirable deals that firms can manage to push through. On the other hand, transparency is undesirable because it imposes a constraint on firms that they can only circumvent at great cost.

We next characterise the trade-off with respect to market structure.

Proposition 3 *The larger the size of the merger, the larger the efficiency region over which the CSS dominates, and the larger the efficiency region over which the CSS is dominated. Moreover, when the CSS is dominated, the efficiency regions for which Type I errors occur shrinks relative to the efficiency region for which waste occurs.*

Proof: We first consider the region where the CSS dominates. Note that A3 can be written as $\partial\tilde{S}^*/\partial M < 0$. The definition of \tilde{e} then implies that $\partial\tilde{e}/\partial M > 0$, i.e. \tilde{e} moves to the right (see also Figure 5). If $\partial S_1^*/\partial M > 0$ (i.e. when merger size has a strong effect on industry profits), then $\partial e_1^*/\partial M < 0$, which implies that the region is getting larger. If $\partial S_1/\partial M < 0$, then $\partial e_1^*/\partial M > 0$, i.e. e_1^* moves to the right. By A3 and A4 and since $\varepsilon'(N - M) > 0$, we have $\partial S_1^*/\partial M > \partial\tilde{S}^*/\partial M$. Since $\partial S_1^*/\partial e > \partial\tilde{S}^*/\partial e$ it follows that $\partial\tilde{e}/\partial M > \partial e_1^*/\partial M$, i.e. the function that has e_1^* as a fixed point shifts by less and is steeper than the function, which has \tilde{e} as a fixed point, so that \tilde{e} moves faster to the right than e_1^* as M increases. We next consider the region where the CSS is dominated.

We first show that this area increases. By A3 and A4 we have $\partial CS^*/\partial M < \partial \tilde{S}^*/\partial M$. Since $\partial CS^*/\partial e < \partial \tilde{S}^*/\partial e$ it follows that $\partial \tilde{e}/\partial M < \partial e'/\partial M$, i.e. the function that has e' as a fixed point shifts more and is flatter than the function, which has \tilde{e} as a fixed point, so that \tilde{e} moves less to the right than e' as M increases. We now show the last statement of the proposition. By A3 and A4 and since $\varepsilon'(N - M) > 0$, we have $\partial S_2^*/\partial M > \partial CS^*/\partial M$. Since $\partial S_2^*/\partial e > \partial CS^*/\partial e$ it follows that $\partial e'/\partial M > \partial e_2^*/\partial M$, i.e. e' moves faster to the right than e_2^* as M increases. Q.E.D.

Proposition 3 indicates that in the presence of larger mergers, both standards perform relatively worse, to the extent that the range of parameters for which either standard yields inefficient outcomes increases.

Consider those mergers which reduce welfare but are pushed through under the welfare standard. Larger mergers tend to reduce welfare for any level of the efficiency parameter, so that in principle firms have to provide more inducement in order to push them through (i.e. \tilde{e} moves right - see Figure 5). However, larger mergers also enhance the profits that are available to provide inducement to the agency. Under the assumptions of our model⁶, the latter effect always dominates the former so that the range of parameters for which inefficient mergers are pushed through increases.

Proposition 3 also illustrates that increasing the size of a merger does not necessarily lead to more regulatory clearance. When increasing the size of mergers has a strong effect on the industry profits, more precisely when $\frac{\partial S_1^*}{\partial M} > 0$, then e_1^* moves left (see the proof of proposition 3), regulatory clearance will never be jeopardised by larger mergers. However, when the effect of larger mergers on industry profits is smaller, more precisely $\frac{\partial S_1^*}{\partial M} < 0$, then e_1^* moves right but by less than \tilde{e} . In this case, there will be a range of efficiency parameters for which regulatory clearance will be jeopardised as the merger becomes larger.

Consider the range of efficiency parameters for which the consumer surplus standard yields an inefficient outcome. As mergers become larger, both welfare and consumer surplus are reduced (so that both \tilde{e} and e' shift right). Under the assumptions of our model, the effect on consumer surplus is greater than the effect on welfare so the range of parameter for which the consumer surplus standard yields an inefficient outcome increases (e' moves further to the right than \tilde{e}). However, Proposition 3 also shows (see the proof) that e' moves further to the right than e_2^* , which implies that the relative size of the regions for which a type I error occurs under the consumer surplus standard

⁶It follows from the fact that welfare is less affected by efficiency than industry profits and by the fact that welfare is an average of profit (which increase with merger size) and consumer surplus (which decreases with merger size).

tends to shrink relative to the region for which there is wasteful lobbying. The reason is as follows: when the size of the mergers increases, consumers surplus fall and more inducement has to be provided to the agency. However, industry profits also increase so that more inducement is available. As before, under the assumptions of our model⁷, the latter effect dominates the former and the range of parameter for which successful lobbying arises increases. As a consequence, the range of parameter for which a type I error occurs will shrink relative to the range for which successful – but wasteful – lobbying arises.

Having considered how the ranges of efficiency parameters for either standard is inefficient change with merger size, the next propositions analyse how merger size changes the relative costs and benefits of the two standards.

Proposition 4 *When the CSS dominates, larger mergers increase the net benefit of the CSS standard, whenever $\frac{\partial S_1^*}{\partial M} > 0$, i.e. when increasing merger size has a strong effect on industry profits.*

Proof: Consider the region where the CSS dominates. By A3 and Lemma 2, we know that $F_m + F_c$ increases in M . Using Lemmata 7 and 8, it follows that $\partial(W_1 - W_2)/\partial M < 0$ in this region. When $\frac{\partial S_1^*}{\partial M} > 0$, e_1^* moves left and the net benefit of the CSS increases. Q.E.D.

The intuition behind this proposition is straightforward. As discussed above, when increasing the size of mergers has a strong effect on industry profits, it will never jeopardise regulatory clearance. In other words, the range of efficiency parameters for which the mergers are pushed through with a given merger size includes the set of efficiency parameters for which the mergers are pushed through with any lower merger size. In addition, for any value of the efficiency parameter, a larger merger size implies that the type II error is more costly and that a stronger inducement (hence more waste) has to be provided to the agency to push the merger through. In those circumstances, the cost of the welfare standard is thus unambiguously greater.

When increasing the size of mergers has a weaker effect on industry profits, the matter is less clear. In those circumstances e_1^* moves right, and some larger mergers (with low efficiency) are blocked, which is first best.

Proposition 5 *When the CSS is dominated the effect of larger mergers on the net cost of the CSS is ambiguous. However, the CSS is more attractive with larger mergers whenever the lobbying is efficient, and when marginal co-ordination costs are high.*

⁷It follows from the fact that consumer surplus is less affected by efficiency than industry profits and by the fact that welfare is an average of profit (which increase with merger size) and consumer surplus (which decreases with merger size).

Proof : Note that $\partial \tilde{e}/\partial M$ and $\partial e'/\partial M$ are unaffected by α , β , and ε' . Further note that $\partial S_2^*/\partial M$ is increasing in α , β , and ε' which implies that $\partial^2 e_2^*/\partial M \partial \alpha$, $\partial^2 e_2^*/\partial M \partial \beta$, and $\partial^2 e_2^*/\partial M \partial \varepsilon'$ are negative. The result follows then from Lemma 9. Q.E.D.

Proposition 5 confirms that the effect of merger size on the cost of the consumer surplus standard is ambiguous. This should not come as a surprise given that increasing the merger size both increases and shifts rightward the range of parameters for which the consumer surplus standard yields an inefficient outcome.

The second part of the proposition uncovers a complementarity between merger size and the efficiency of the lobbying process: the effect of merger size on the range over which the consumer surplus standard yields inefficient outcomes is unaffected by the efficiency of lobbying. But the effect of merger size on the region over which a type I error occurs within that range is negatively influenced by the efficiency of lobbying. The more efficient the lobbying, the more the region over which type I errors occurs will shrink when merger size increases. Hence, not only does lobbying reduce the cost of the consumer surplus standard on its own right (see above), but it also makes the consumer surplus standard more attractive when merger size increases.

Collecting the above results, we find that efficient lobbying and large mergers reinforce each other in reducing the cost of the consumer surplus standard in regions where it yields an inefficient outcome. Where the welfare standard yields inefficient outcomes, large mergers make matters worse independently of the efficiency of lobbying (at least when larger mergers have a strong effect on industry profits).

5 Conclusion

This paper evaluates alternative rules that can be assigned to a merger control agency which can be influenced by interested parties. We find that neither a welfare standard nor a consumer surplus standard dominates. The consumer surplus and welfare standard also give rise to different types of inefficiencies: relatively inefficient mergers – which decrease welfare – are pushed through under a welfare standard, while relatively efficient mergers (which would increase welfare) are prohibited under the consumer surplus standard. While lobbying activity is undesirable under a welfare standard, it raises welfare under a consumer surplus standard.

The process of lobbying - as characterized by transparency and co-ordination costs - is shown to be important in terms of the relative performance of the two standards. Both transparency as well as co-ordination costs make lobbying less effective. Under a welfare standard this has two effects. On the one hand, it will reduce the scope of undesirable deals that firms can manage to push through. On the other hand, transparency and

co-ordination costs impose a constraint that firms can only circumvent at a cost. By contrast, transparency or co-ordination costs do not affect the scope of deals for which a consumer surplus standard is inefficient. It only affects the balance between wrong decisions and waste in lobbying. For instance, more transparency actually shift the balance towards wrong decisions because it reduces firms's effectiveness in lobbying. Since wrong decisions are socially more costly than lobbying, transparency is actually not desirable under a consumer surplus standard.

We also find that the size of the proposed merger has a different impact on the performance of the two standards. Under the welfare standard, there are two effects. On the one hand, larger mergers, which have more resources to lobby the agency, manage to push more numerous deals through, despite the fact that larger deals are also less desirable in terms of welfare (and hence require more lobbying to be pushed through). On the other hand, the deals that are pushed through may on average be less damaging so that the overall effect is ambiguous. Still, when industry profits are strongly affected by the size of the merger, the former effect will dominate and the welfare standard will perform relatively worse.

The matter is different for a consumer surplus standard. The range of deals for which inefficient outcomes arise increases with larger mergers. But larger mergers also tend to shift the balance away from wrong decisions and in favour of wasteful lobbying (because firms have more resources). As result, the performance of the consumer surplus standard is not unambiguously worse with larger mergers. In addition, we observe that larger mergers will shift the balance away from decisions errors more firmly when transparency is low. Hence, low transparency and larger mergers are circumstances that reinforce each other in making a consumer surplus standard more attractive.

These findings suggest that a reform of the standard that is assigned to a competition agency needs to consider the institutional environment in which the agency operates and the population of cases that the agency is likely to consider. For instance, it may not be appropriate for the EU to move towards a welfare standard unless the transparency of its procedure is greatly improved. The average size of proposed mergers has been unusually large in the recent merger wave (see European Economy, 1999). If one expects this feature to persist, our analysis would imply that maintaining a consumer surplus standard may be appropriate.

References

Besanko, D. and D. Spulber, 1993, Contested mergers and equilibrium antitrust policy, *The Journal of Law, Economics and Organisation*, 9 (1), 1-29.

Bernheim, D. and M. Whinston, 1986, Common agency, *Econometrica*, 54 (4), 923-942.

Bond, E., (1996), Competition Policy in Customs Unions: a Natural Experiment using State Level Antitrust Enforcement, mimeo, Penn State.

European Economy, 1999, Merger and Acquisitions, Supplement A, Economic Trends, 2.

Gellhorn E. and W. Kovacic, 1994, *Antitrust Law and Economics in a Nutshell*, West Publishing, St. Paul.

Grossman G. and E. Helpman, 1994, Protection for sale, *American Economic Review*, 84(4), 833-850.

Figure 1
Structure of the Game

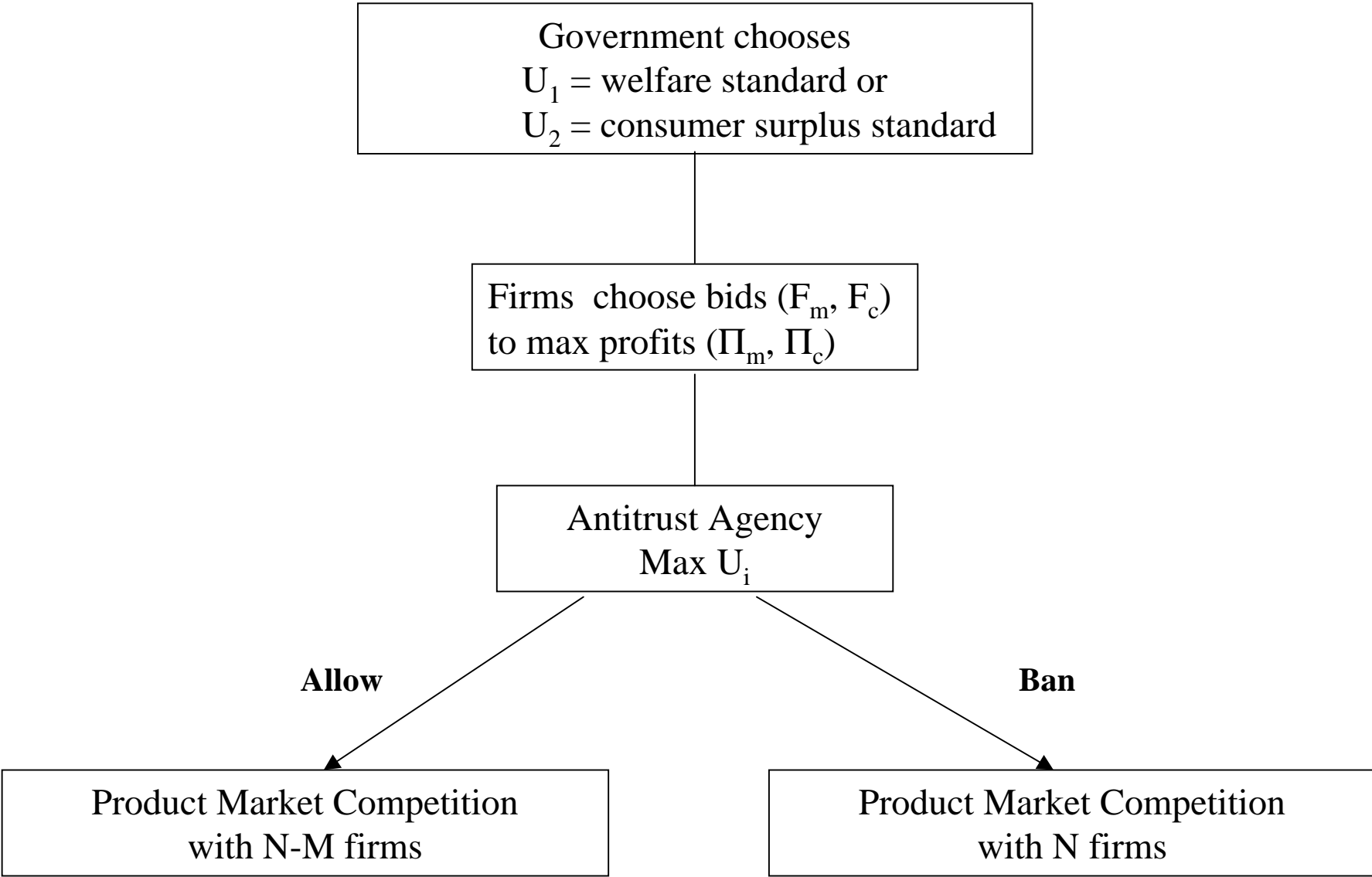

Figure 2
Efficiency, Profits and Welfare

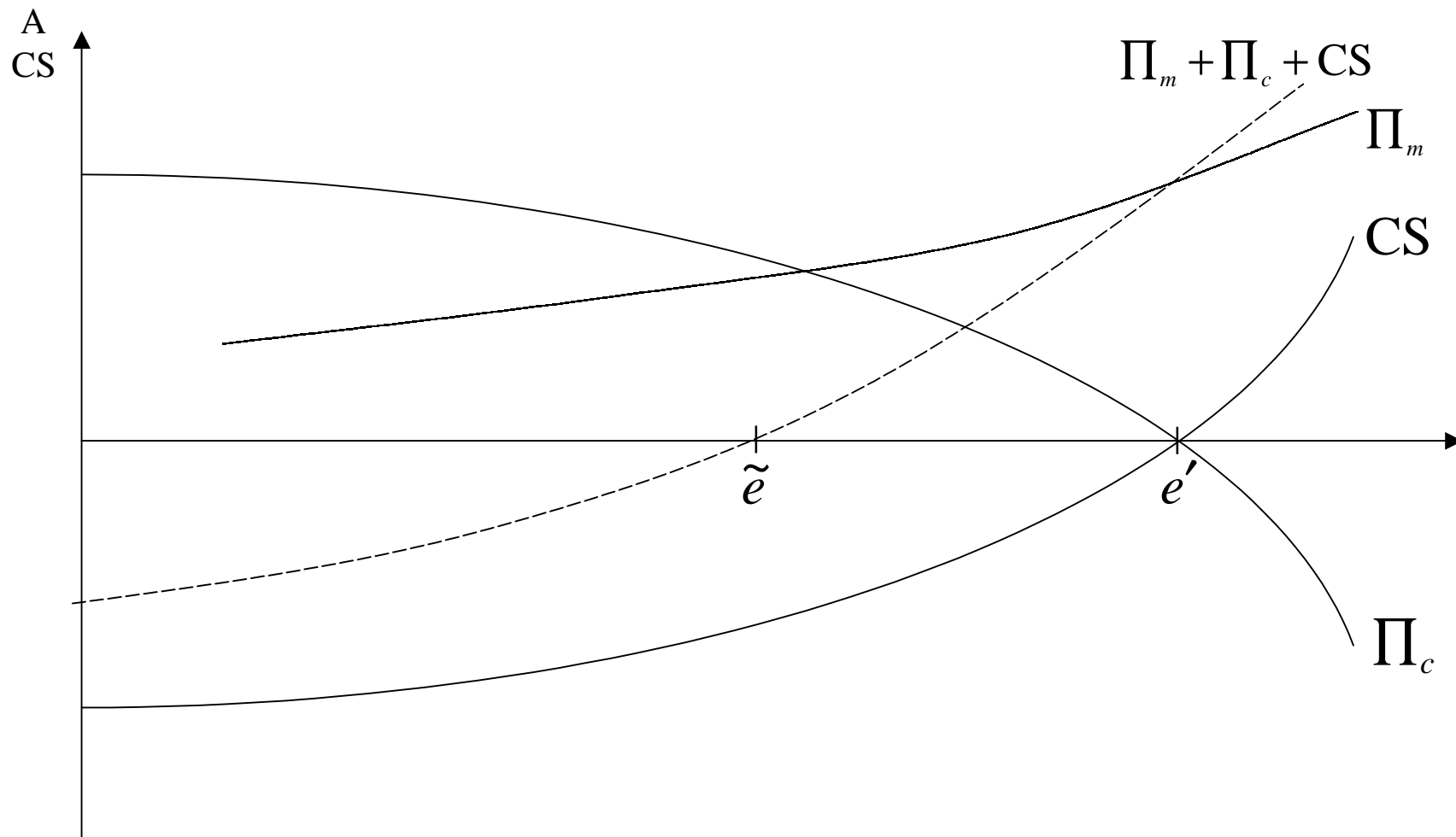

Figure 3

$$W_1 - W_2$$

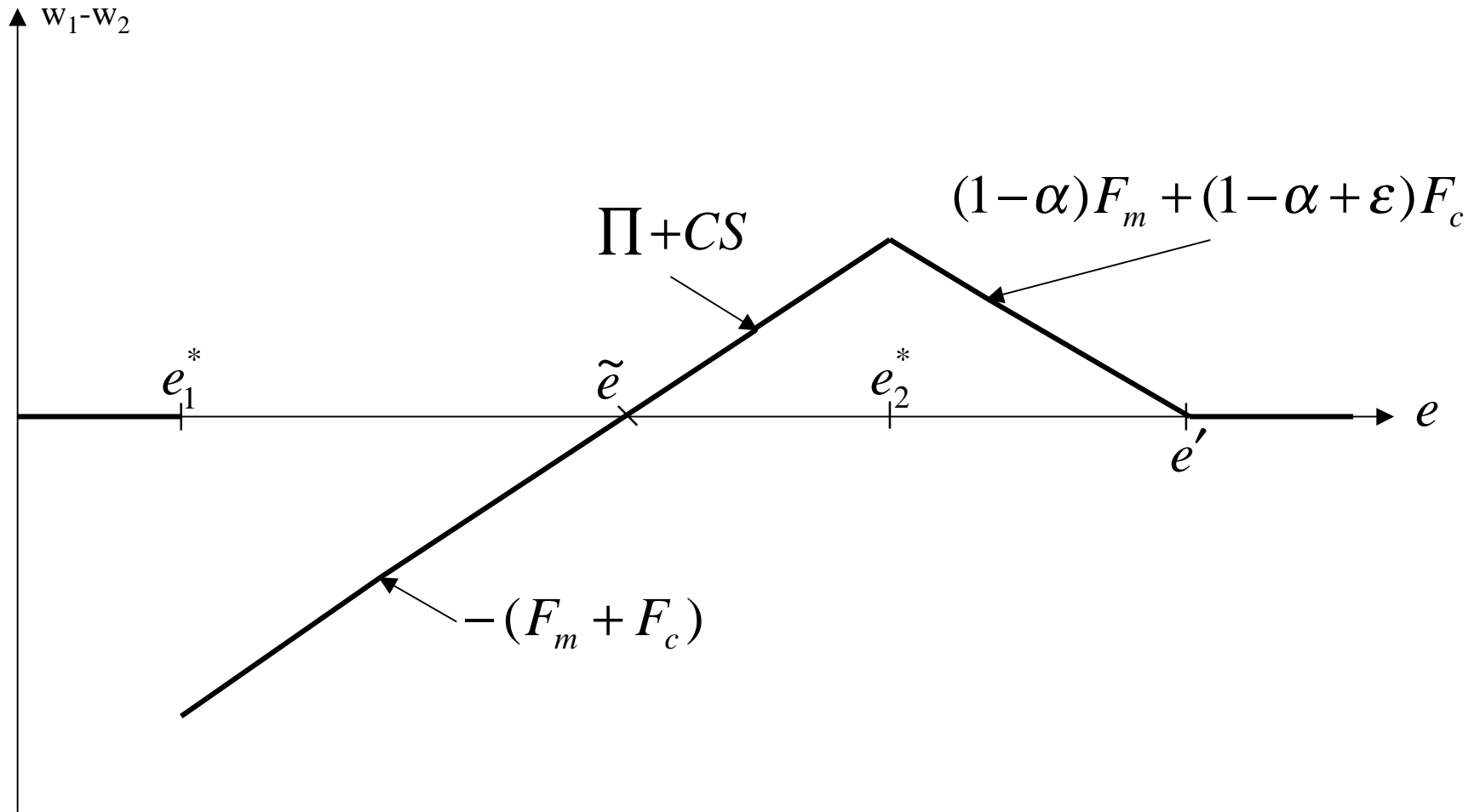

Figure 4
Comparative Static with Respect to the Political Economy

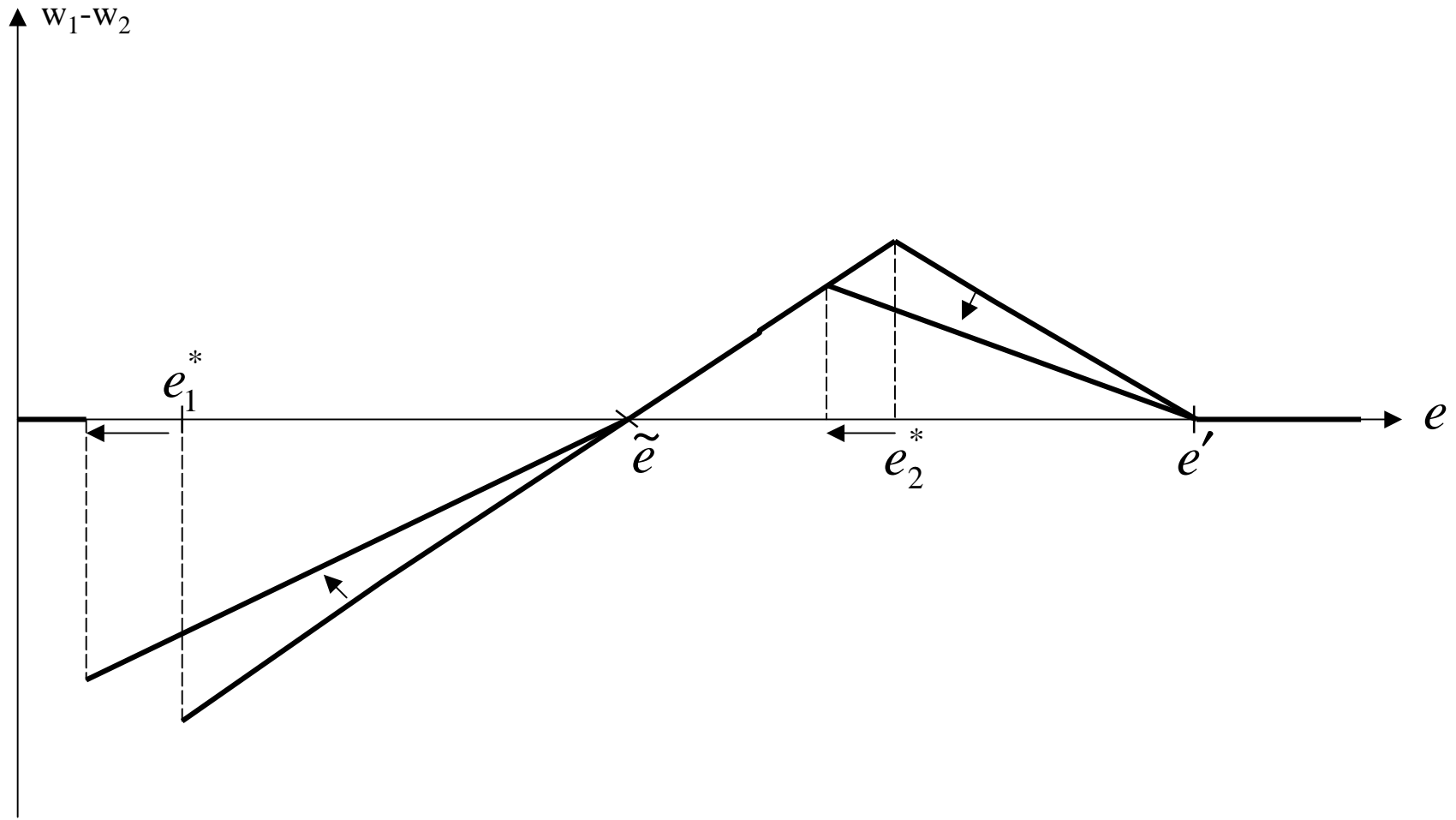

Figure 5

Comparative Static with respect to M and Complementarity between the Political Economy and the Size of the Merger

