

## Transformation conditions of future factory structures: technology, organization, education and vocational training

Schultz-Wild, Rainer

Veröffentlichungsversion / Published Version

Sammelwerksbeitrag / collection article

**Zur Verfügung gestellt in Kooperation mit / provided in cooperation with:**

Institut für Sozialwissenschaftliche Forschung e.V. - ISF München

### Empfohlene Zitierung / Suggested Citation:

Schultz-Wild, R. (1987). Transformation conditions of future factory structures: technology, organization, education and vocational training. In P. Brödner (Ed.), *Strategic options for "New Production Systems" - CHIM: Computer and Human Integrated Manufacturing (internal paper)* (pp. 50-72). Brüssel <https://nbn-resolving.org/urn:nbn:de:0168-ssoar-107704>

### Nutzungsbedingungen:

*Dieser Text wird unter einer Deposit-Lizenz (Keine Weiterverbreitung - keine Bearbeitung) zur Verfügung gestellt. Gewährt wird ein nicht exklusives, nicht übertragbares, persönliches und beschränktes Recht auf Nutzung dieses Dokuments. Dieses Dokument ist ausschließlich für den persönlichen, nicht-kommerziellen Gebrauch bestimmt. Auf sämtlichen Kopien dieses Dokuments müssen alle Urheberrechtshinweise und sonstigen Hinweise auf gesetzlichen Schutz beibehalten werden. Sie dürfen dieses Dokument nicht in irgendeiner Weise abändern, noch dürfen Sie dieses Dokument für öffentliche oder kommerzielle Zwecke vervielfältigen, öffentlich ausstellen, aufführen, vertreiben oder anderweitig nutzen.*

*Mit der Verwendung dieses Dokuments erkennen Sie die Nutzungsbedingungen an.*

### Terms of use:

*This document is made available under Deposit Licence (No Redistribution - no modifications). We grant a non-exclusive, non-transferable, individual and limited right to using this document. This document is solely intended for your personal, non-commercial use. All of the copies of this documents must retain all copyright information and other information regarding legal protection. You are not allowed to alter this document in any way, to copy it for public or commercial purposes, to exhibit the document in public, to perform, distribute or otherwise use the document in public.*

*By using this particular document, you accept the above-stated conditions of use.*

No. 150

February 1987

STRATEGIC OPTIONS FOR  
"NEW PRODUCTION SYSTEMS" -  
CHIM: COMPUTER AND HUMAN  
INTEGRATED MANUFACTURING

P. Brödner (Ed.)

INSTITUT FÜR SOZIALWISSEN-  
SCHAFTLICHE FORSCHUNG E.V.  
8 MÜNCHEN 40  
JAKOB-KLAR-STR. 9

8790

Internal paper

X11-145-87

## TABLE OF CONTENTS

Preface and Introduction by FAST and CEDEFOP

CHIM: Computer and Human Integrated Manufacturing

**PART 1**      Summary

**PART 2**      Contributions from Members of the Working Party

- P. Brödner:            Options for CIM "Unmanned" Factory versus Skill Based Manufacturing
- R. Schutz-Wild:      Transformation Conditions of Future Factory Structures: Technology, Organisation, Education and Vocational Training
- F. Prakke              Interrelationships between Firms in Manufacturing
- B. Haywood,  
J. Bessant            The Integration of Production Processes at Firm Level
- G. Lay:                Strategic Options for the Integration of Production Processes at Firm Level (CIM)
- F. Manske:            Alternative Strategies of Production Planning and Control (PPC)
- H.J. Braczyk:        Human Centred Technology, Strategic Options and Users' Consent
- M. Corbett:           Strategic Options for Human-Machine Interface Design

Part 3

Recommendations

- P. Brödner: Recommendations for Human Centred Options in Computer Integrated Manufacturing
- M. Corbett: Recommendations for R & D Action in Human-Machine Interface Design
- G. Lay: Recommendations for Human Centred CIM Architectures and its Elements
- F. Manske: Recommendations for Alternative Production Planning and Control Systems
- H.J. Braczyk: Recommendations for the Procedure of Technological Design
- B. Haywood:  
J. Bessant: Recommendations for Documentation of Economic Effects of Organisational versus Technological Approaches
- B. Sellin: Recommendations for Initial and Continuing Training for New Manufacturing Systems

## PREFACE AND INTRODUCTION

### FAST AND CEDEFOP

#### CIM: COMPUTER AND HUMAN INTEGRATED MANUFACTURING

1. The aim of the TWE 7 FAST/CEDEFOP research activity on "New Technical Production Systems: Work in the Factory of the Future - Vocational Training Implications and Policies" was to study future aspects of advanced manufacturing. The research has focused on innovation in terms of technology, organisation and human factors and its implications for science and technology policies, as well as its impact on vocational training. Therefore the FAST<sup>1</sup> Programme, Brussels and the European Vocational Training Centre, CEDEFOP, Berlin, launched a cosponsored research activity in 1984.
2. The point of departure was the assumption that progress in microelectronics and the development in information technologies would give rise to a new future of production facilities, working life and manufacturing methods. On a long term basis, the design and planning offices, together with manufacturing and quality control might be heavily affected by new information technologies. In particular, the emergence of "integrated and flexible production systems" (with its elements of CAD, CAM, FMS, CIM) as opposed to the old, "stand alone", rigid automation facilities might lead to a new phase of manufacturing. In order to throw some light on this future production trend, the research activity was organised into 3 phases.
3. The first phase focused on "Flexible Manufacturing Systems" (FMS) which is the most advanced part of the traditional factory automation concepts, but now uses the advantages of new information technologies (NIT). Study has mainly been directed

---

<sup>1</sup> Forecasting and Assessment in Science and Technology

at the diffusion of FMS and FMC (flexible manufacturing cells), work organisation and skills, together with the analysis of forms of flexible production based on new organisational concepts.

The research was carried out by  
IREP Grenoble (France)  
ISI Karlsruhe / ISF Munich (Germany)  
Roskilde University (Denmark).

Attached to these three main teams was the Vrije Universiteit Brussels, which carried out a separate study of Belgian flexible production approaches<sup>2</sup>.

4. In a second phase, the results of the studies were presented and discussed at a conference in Turin in July 1986, involving the participation of around 150 experts in the field, 45 of whom gave written contributions. In brief, the main conclusions were that organisation is a key issue of the economic success of future production which is at least equal to technology, and the "concept of production" or the "production culture" is important for usage and the kind of technology applied, organisation of work and demand for skills.<sup>3</sup> This can be stated because of the approach of the comparison taken by the conference towards technology, organisation, vocational training and small and medium production units.<sup>4</sup>

-----  
<sup>2</sup>See research reports:

P.H. Kristensen: Industrial Models in the Melting Pot of History, FOP No. 109, Brussels, August 1986

M. Hollard, G. Margirier, A. Rosanvallon: L'Automatisation avancée de la production dans les activités d'usinage, FOP No. 124, Brussels, November 1986

ISI-ISF: Flexible manufacturing systems and cells in the scope of new production systems in Germany, FOP No. 131, Brussels, January 1987

P. Kool et al: The impact of new technologies and flexible manufacturing in a Belgian context, FOP No. 154, Brussels, March 1987

<sup>3</sup>See u.a. A. Sorges' Conference Report in CEDEFOP Flash 6/1986, Berlin 1986

<sup>4</sup>W. Wobbe (Ed.): Flexible Manufacturing in Europe - State of the Art of Approaches and Diffusion Patterns, FOP No. 155, Brussels, March 1987

5. The third phase - the results of which are embodied in this volume - has tried to take a step forward by giving recommendations to the European Communities concluded from the research results. FAST organised a working party of selected experts chaired by P. Brödner from the German "Projektträger Fertigungstechnik" of the Kernforschungsanlage, Karlsruhe. The observed strategic option in future manufacturing could be concluded in the CHIM concept (computer and human integrated manufacturing) which tries to put forward ideas which are lacking in the discussion on the technologically oriented (or technocentric) concept of computer integrated manufacturing (CIM). The working party has not put forward a closed concept of CHIM, but has collected lots of elements which could be arranged and used for new Science and Technology (S & T) orientation, vocational training measures and European production policies.
  
6. After meeting and agreeing on basic lines, the experts of the working party have drawn up papers which were discussed in a highly intensive workshop on 8th-10th December, 1986 in Brussels. These contributions were revised as the result of the discussion and resubmitted for publication in this document. In general, they all reflect the following views:

The future of European manufacturing in competition with the US, Japan and the Pacific region seems to lie in (a) complex, customer tailored, quality products, (b) efficient maintenance services and (c) high flexibility and time regulated production. This type of production can be built on human resources and knowledge which already exist in the industrialised European Member countries, but which has to be promoted more specifically.

7. The assumptions go in the same direction as proposed by the Danish TWE 7 research work which underlined the possible end of Fordism (or traditional mass production) and its replacement by forms of "flexible specialisation". The old and new types of production could be contrasted in an ideal type of way as follows:

Fordistic Production	Flexible Specialisation
<ul style="list-style-type: none"><li>- standard mass production</li><li>- fewer product variants</li><li>- single purpose technology</li><li>- low skilled workers</li><li>- poor working conditions</li><li>- large production units</li><li>- bureaucratic organisation structure</li><li>- restricted level of R &amp; D activities</li><li>- price competitiveness</li></ul>	<ul style="list-style-type: none"><li>- sophisticated quality products</li><li>- broad range of variants</li><li>- small production units</li><li>- programmable techniques</li><li>- low division of labour</li><li>- skilled workers</li><li>- intensive development inputs</li><li>- high wage levels</li><li>- quality competitiveness</li><li>- intelligent organisation</li></ul>

8. The scheme does not mean that no mass production will survive in Europe in the future, but this type of manufacturing has to change. In a matrix of different production strategies and types, it is emphasised that the challenging future form of manufacturing is sketched in the right hand column which relies on quality competitive products in contrast to the price competitive products and its old manufacturing philosophy.



Classification of Production Strategies

	standardised price competitive products	customised quality competitive products	
low volume  ↓  high volume	specialised component production	craft production	
	catalogue production	skill based automated manufacturing	)flexible ) )
	mass production ("Fordism")	diversified quality production	) ) )specialisation )

In particular, the segments of "skill based automated manufacturing" and "diversified quality production" are concepts of "flexible specialisation", but they operate on different scales.

9. In relation to the orientation of public Research and Development (R & D) funding, it was stated that traditional high volume mass production, together with the price competitiveness aspect, has fostered a "technocentric production concept". This aims at the fully automated or manless factory. Development is seen in a higher degree of technique application. Man has been considered implicitly as a temporary factor to fill in gaps which would later be replaced by technology. Organisations had to follow the production flow of continuous manufacturing with less production changes and demands on skills and organisation have been routine

functions. This could also be called the tayloristic model. The CIM (computer integrated manufacturing) factory seemed to be the new approach of the technocentric ideals. However, it has become evident that the CIM factory (when it eventually exists) will not be an unmanned factory. Contrary to earlier automation technologies which try to substitute shop floor personnel with machinery, CIM is a communication tool which influences the organisation and cooperation inside and outside the enterprise. It provokes changes in skills and managerial competence.

10. These facts prove that "new production concepts" have to be developed which, besides technology, includes skills and organisational factors. We call this CHIM (computer and human integrated manufacturing). This concept focuses on production processes as a response to rapidly changing market demands and complex products, as well as on smaller production units. The investment goods industry, the engineering sector, the garment industry are good examples for this type of production. In this economic sector, small and medium sized enterprises dominate.
11. Until now, the orientation of large firms towards the development of new technologies and the direction they should take has dominated R & D funding. Because of their low mechanisation level and small scale production, it was considered that small production units were historically obsolete, and should be phased out in the foreseeable future. However, the trend towards flexible specialisation has shown that there is an increasing role for small production units in the future economy. Therefore, it is very important to face this reality and the specific production modes of small manufacturing units and
  - develop adequate technologies
  - organisational pattern
  - skilling schemes
  - management schemes
12. In terms of the science and technology and vocational training policy priorities, concepts for manufacturing have to be supported which are based on low division of work, changing

organisation, flexible technology, considering skills as an important element to master highly different demands in changing production requirements. Therefore, the following elements need to be developed:

- antropocentric technology (human centred). This means that machines should not just be built to produce an article, with man to compensate for what the machine cannot achieve (Restarbeit). Machines have to be developed as a modern tool of man's competence. Computer programmes will aid the decisions and actions made by man. Examples are to be developed for CNC machines, PPS systems, robots, CAP, CIM systems.
- The organisational knowledge and the organisation itself has to be developed. It can no longer be a routine and hierarchic type. By contrast, it has to consider quick responses and changing demands. Therefore, organisational technologies and the firm's structure have to fit in. This knowledge and its application have to be diffused (orgknow) and the tools by which to do it have to be examined.
- Skills from the management side as well as from the worker have to be developed to meet the demands of flexible response of steadily changing production. With regard to the shop floor, the concept of the German "Facharbeiter" is a starting point for this demand.

In conclusion, this concept could be called CHIM: a core of small production units with a quick response to the market producing high quality products. It demands flexible technology, Orgknow and hybrid skills. It is a concept which uses organisation integrating adequate technology and human resources as its starting point.

13. The TWE 7 working party commenced with a plan of producing a strategic document for the orientation of a science and technology policy and that of vocational training. It contains different levels for tackling the subject.

L.1. Options for computer integrated manufacturing

"Unmanned factory vs. skill based manufacturing (CIM or CHIM)

- . abilities of man and properties of machines ("contrasting" work design)
- . control of production
- . economics of production
- . rule based versus tacit knowledge
- . triad trends (global competition)
- . industrial structure

L.2. Education and training

- . vocational training
- . social skills
- . engineering education
- . distribution of skills and knowledge

L.3. Interrelationships between firms

- . subcontracting
- . regional development
- . precompetitive collaboration

L.4. Integration of production process at firm level

- . organisational concepts
  - division of labour vs. "holistic" systems
- . organisational development
- . power relationships
  - (central/decentral, degree of autonomy)
  - decision making (participation)
- . technological concepts
  - system architecture
  - (openness of systems)

To be discussed for types of production (high volume vs. small batch) and functional interfaces (design, production, planning).

L.5. Man-machine relations

- . division of functions
- . interaction

(e.g. direct object manipulation, "computer aided craftsman")

The arrangement of contributions by the author has followed this plan, as the Chairman, P. Brödner, summarises.

14. Many elements for elaborating the CHM concept and orientations for research and development can be found in the experts' papers compiled in this book. In particular, recommendations for the orientation of new man/machine/organisation relationships have been put forward, taking the viewpoint of organisational demands or the users' demand as a starting point for developing technological facilities to assist the production process. In the field of initial and continuous training, a broader orientation is recommended for assuring human resources in future production.

Werner Wobbe - FAST

Georges Dupont - CEDEFOP

Burkhard Sellin - CEDEFOP

Brussels, February 1987

**PART 1**

**SUMMARY**

## SUMMARY

The conception and development of new production systems are considered at the following five levels:

1. Options for computer integrated manufacturing (CIM)
2. Education
3. Interrelationships between firms
4. Integration of the production process at firm level
5. Man-machine relations.

At level one, P. Brödner argues that, due to the shift from steady expansion to tendencial stagnation on the world markets, traditional production systems (like small batch production or Fordism) have to be adapted to the new market requirements in some way or other. Regarding the different product and production strategies coping with the triad trends of global competition, the European industrial core seems to have a comparably stronger competence for the strategies of "flexible specialization" and "diversified quality production" than other industrial areas. Since namely the first strategic option is of particular importance with respect to competition by displacement, it will mainly be brought into the focus throughout this volume (although other types of production will co-exist for a long time).

The manifold production concepts considered for future manufacturing processes can be located between two poles characterized by the key words "unmanned factory" versus skill based manufacturing. Whereas the technology centred approach regards humans as a source of failure rather than a productive force and consequently attempts to deepen the division of labour, to replace human abilities by computer programs and to reduce skill requirements, the opposing human centred approach claims to join the unique human abilities with machine performance productively, to reintegrate planning and operating tasks in working groups and to acquire appropriate skills.

Due to the growing awareness of the deep dilemma~~the~~ the technology centred approach is going to run into that can be circumvented, however, by the human centred alternative, the latter seems to gain more and more attractiveness. In order to make productive use of human skills and to actually enable the workers to use computers as tools rather than being replaced by them, work design (i.e. the determination of the division of labour, of the partition of functions between human and machine, and of the modes of human-machine interaction) has to be done in such a way, that a wide margin of action is being preserved leaving initiative, evaluation and decisions up to the worker. On the other hand, functions and behaviour of the computer have to be completely transparent.

Furthermore, altered politics of production and alternative forms of controlling its processes are being developed within the new production concepts. In contrast to traditional forms, where control used to be exercised by objectifying knowledge, by the detailed working instructions derived from that, and by the machine system used, it is now exerted through computer assisted central planning and supervising of production in its entirety, but leaving much wider margins for local planning and execution. It is additionally supported by a performance policy challenging the workers' competence, autonomy and responsibility.

Despite its clear economic and social advantages over the technology centred production concept, the human centred one faces strong forces of inertia, however. They result from a firm's hardware, software, social system and prevailing ideology, the latter two offering the by far harder resistances against change. The new production systems cannot disseminate widely unless these barriers have been surmounted.

At level two, R. Schultz-Wild stresses, to begin with, the differences with respect to basic conditions and developmental perspectives between regions, countries and branches, which make it appear rather doubtful that questions of technology utilization, work organization and skill formation will be solved according to an uniform pattern. Nevertheless, a variety of factory structures is being advocated that are all aiming for a combination of technology and labour preserving production competence on the shop floor, and for a process-related utilization of skills and qualifications rather than following the lines of using computers for maximum automation.



The process-related utilization of skills and qualifications offers a number of benefits such as saving planning and implementation costs, reducing training expenses or increasing the availability of complex and expensive manufacturing systems. They make this approach attractive for a company regardless of the specific structures in which it might be realized. These new forms of manufacturing structures and work organization depend, however, on a number of preconditions such as the market supply for manufacturing computer systems, the implementation processes of new manufacturing technology, the availability of different skills and qualifications, gratification systems and career patterns.

Several problem constellations in the field of education and training related with future factory structures are outlined.

First, there is the issue of the education and training system's capability of securing adequate manpower reserves being closely related with the attractiveness of industrial work itself.

While, second, knowledge and skills related to products and manufacturing methods remain important, new knowledge concerning the use of EDP and control technology is becoming increasingly important.

Third, there is the problem of adequately combining theoretical knowledge with the practical aspects of work.

Fourth, the form in which advanced technical knowledge is taught has an important impact on future industrial structures, since technicians and engineers form a growing part of the workforce and the teaching and research traditions they grow up with tend to prejudice the company's decisions on technological innovation.

Fifth, the capacity and efficiency of vocational retraining is becoming crucial as soon as new industrial structures spread widely.

Sixth, new forms of process-related utilization of skills and qualifications within complex manufacturing systems require a high capability and willingness for cooperation which partly contradict traditional forms of individual learning and work performance. New forms of collective learning must, therefore, be supported by adequate wage systems and career patterns.

At level three, F. Prakke<sup>\*</sup> considers interrelationships between firms in terms of economic and technical trends of subcontracting (being the most important aspect), regional cooperation and precompetitive collaboration.

\* Final paper not received within scheduled time limit

The fact that customers under duress tend to pass on their short term production requirements to the subcontractors make long term improvements of their manufacturing technology nearly impossible. In general, hence, quality and flexibility requirements in subcontracting are rising quite rapidly, while customers are reducing the number of their contractors. Firms confining themselves to their core production processes, on the other hand, are causing further specialization and, therefore, more subcontracting.

OEM's increasingly try to share the development risks with their component suppliers, while at the same time design cycles tend to be shortened by competitive pressure. Thus, contractor relationships are increasingly requiring much closer technical contacts between the partners, which, in turn, makes standardization of data exchange interfaces and software necessary.

Regional cooperation seems to be enforced by the requirements of consequent just-in-time production and the increased use of services by manufacturers. Regional development, therefore, must be based on specialization.

Precompetitive collaboration offers benefits in particular for small and medium sized firms. Since it is especially hard for them to cope with rapid technological and organizational change, they can draw specific advantages from precompetitive programs for training, retraining and consulting.

At level four, B. Haywood and J. Bessant argue that, due to internal and external pressures, firms are being forced to reduce costs and complexity, but also to improve quality, reduce lead times and the overall uncertainty of the production process. The tools mostly considered to tackle this problem (e.g. CAD, CAM, FMS etc.) are purely technological in nature and constitute the issue of technical integration.

But even when that can be sufficiently solved by standardization, the full benefits expected from such systems do not materialize because this technical view overlooks the necessity of adequate organizational integration by structural and methodological measures like changes in patterns of task and work organization, new skill profiles or group technology, just-in-time, total quality control respectively. Evidence suggests that far more than half of the benefits of innovation come before the technology (in this case FMS) itself is implemented.

In order to achieve an integrated technology embedded in an integrated organization, a manufacturing strategy is needed being itself linked to an overall business strategy. Such a strategy has to take all parts of the manufacturing process into account rather than to focus on the production area alone.

In a more specific view G. Lay outlines the basic components and data exchange interfaces for implementing CIM considering the islands of computer applications already grown within the borders of firm departments. Although the trend towards technical integration of different computer systems is inevitable, it nevertheless appears possible to combine this technical potential of CIM with organizational structures that favour holistic job structures and qualification processes.

Such human centred CIM concepts have to meet certain requirements, however. These are, briefly mentioned, a decentralized system architecture with a distributed data base and with software modules that support humans to take initiative and make decisions locally where the real working process is going on. Furthermore, such integrated systems have to be equipped with a common human-machine interface. This kind of system architecture promises to be compatible with a work organization that provides holistic job structures (e.g. in the form of so-called design, planning and production islands).

Looking at the state of the art, the market supply of computer systems for manufacturing particularly suffers from insufficient common data structures, inappropriate human-machine interfaces and inflexible data exchange interfaces. For human CIM concepts, this has to be overcome by additional R&D as illustrated in more detail by the example of geometric data exchange between CAD and shop floor programming.

Looking at production planning and control in small batch production, F. Manske points out that the use of computers in this area allows for the first time a centralistic control over production, but as compared with Taylorism (that never succeeded in this type of production) in a rather indirect approach without prescribing detailed instructions for the work process itself. This still being hidden from the planners' eyes, the allocation of smaller volumes of work, more exactly determined completion times together with comprehensive data collection and less disruption by better planning of peripheral activities have now become possible constricting the workers' autonomy.

There are, however, different types of production planning and control systems in use: centralistic planning and job sequencing versus shop floor planning within the frame of centrally controlled order pools. The latter recognizes that many details of the production process (above all the disturbances) are inaccessible to central planning and, therefore, regards the workers as necessary actors in the system. In this view, management leaves them a limited margin for disposition without losing control over production as a whole. It also appears to be compatible with new forms of skilled work (like production islands etc.).

H.-J. Braczyk explains, based on inquiries of the garment industry, the need for a differentiated consideration of strategic options in the use of technology. Manufacturing technology implicitly contains prescriptions on how to use them. Although all system configurations aim at gaining more flexibility in production, some types do provide opportunities for task definitions on higher qualification levels and with more room for disposition, while others do not (i.e. "some technologies are more equal than others").

In the garment industry no communication at all exists between the suppliers and the users on what kind of technology should be developed. Consequently, suppliers develop manufacturing technology according to their own imagination about the most suitable means to meet market requirements. Therefore, the technically embedded options for work design depend on the supplier's view: the more he believes in Taylorism the more he will design the technology in favour of technically provided flexibility at the expense of organizational flexibility.

At level five, M. Corbett points out that despite the vision of "people-less" production systems, as a consequence of which the incorporation of human factors in the design of production technology is becoming increasingly redundant, this will remain an important task of system design. All "technocentric" attempts to design reliable systems without human operation cannot but fail, since they overlook three basic ironies of system design: firstly, that the human element regarded as the major source of uncertainty and, hence, to be eliminated is still needed to cope with the uncertainty caused by unforeseen disturbances, secondly, that the designer trying to eliminate the operator still needs him to do the tasks which he cannot think how to automate, and thirdly, that getting rid of unreliable humans means, due to the incomprehensibly complex software needed, becoming dependent on unreliable systems.

The alternative, "anthropocentric" approach to system design recognizes the incomparable, but possibly complementary abilities of the computer and the human mind (e.g. formal analysis and storage and computation capacity versus synthesis and intuitive reasoning). It identifies three key choice points in design: the allocation of functions between human and machine, the control characteristics of the human-machine interface, and the informational characteristics of the human-machine interface.

In order to design the interaction between human and computer in a way that humans can activate their specific abilities, it must be viewed as a social interaction between operator and designer, in which the designer sets the conditions for the operator's acting. Therefore, it turns out to be a key issue to develop collaborative design methods, where workers can bring in their practical experience from the working process.

A number of recommendations for further actions, mainly in the field of R&D have been drawn from all these papers. They are listed as part three of this volume in the order of the same levels of consideration.

Karlsruhe, January 1987

Peter Brödner

**PART 2**

**CONTRIBUTIONS FROM MEMBERS  
OF THE WORKING PARTY**







OPTIONS FOR CIM: "UNMANNED FACTORY"  
VERSUS SKILL BASED MANUFACTURING

CEC-FAST Working Party on  
"New Production Systems"

by

Peter Brödner

Kernforschungszentrum Karlsruhe GmbH  
Projektträger Fertigungstechnik  
Postfach 36 40, D-7500 Karlsruhe 1

December 1986

Contents:

1. Global Competition: Triad Trends
2. Economics of Production
3. Knowledge of Production
4. Politics of Production
5. Conclusion: The Better Choice

## 1. Global Competition: Triad Trends

During the last two decades we witnessed dramatic changes on the world markets. The markets for industrial consumer goods and, consequently, those for capital goods too, shifted from steady expansion to tendencial stagnation. For some capital goods, this tendency may appear to be even enforced, as the example of the machine tool industry demonstrates, by the circumstance that the performance per unit of their products increases faster than their functionality by value.

This lasting global trend will not be affected by the large potential of unsatisfied needs in the developing countries, since the terms of trade in general and their immense indebtedness in particular hinder them to turn the needs into spending power for industrial goods for a long time to come. Thus, the world markets are and will remain constrained to the highly industrialised areas and so called threshold countries comprising the areas of North America, Western Europe and South-East Asia (the Comecon countries being only slightly tied up, see Fig. 1).

**VDI nachrichten Nr. 46 / 15. November 1984 Seite 9**

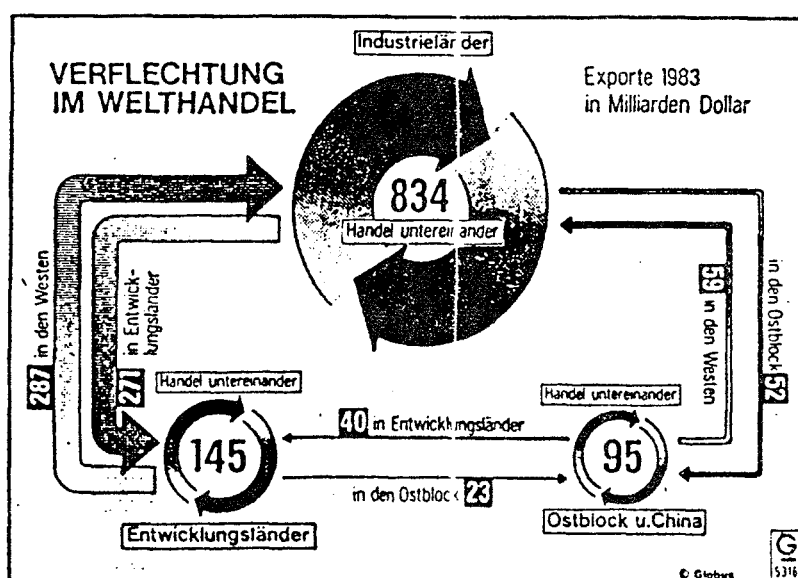

Fig. 1: Main streams of world trade in 1983

The overall low growth rates on these limited markets indicating the change from expansion to stagnation have the effect that competition also changes its character from supplying expanding market shares, where the suppliers were able to set the conditions to a large extent, over to displacing competitors, whereby customers gain the power for buying products adapted to their needs. Under these new market conditions of competition by displacement, price and quality of unified products are no longer the only assets to win the race. The abilities to adapt the products to customer requirements with increasing variety and yet to guarantee short delivery times are becoming rather more important competitive factors. This has, in turn, great impact on the internal conditions of operation of the entire manufacturing process, as to be shown below.

The triad regions of competition happen to have considerably different industrial structures. With respect to productivity, product mix, production processes, skill profiles and industrial relations, these differences can be briefly characterized as follows.

The region of Northern America, predominantly formed by the rapid industrialization process in the North-East, developed a most sophisticated mass production due to the huge and rapidly expanding home market. Hand in hand with this, a most effective machinery and machine tool industry delivering capital goods of high performance arose and developed. Since the majority of the workforce was unskilled or at least not used to metal working (many workers had been recruited among the black from the South or among the immigrants from Europe), but showed the more willfulness, strong methods to get and keep control over production and to achieve pertinent and timely work had to be established. Thus, it is with necessity rather than by chance that Taylorism and Fordism originated in the USA, spread widely in this region and became the prevailing paradigm of production for the industrial world. In recent years, the pattern changed considerably, however. The decline of productivity (the annual growth rates of productivity in industry decreased from an average level of 2.8 in the sixties to 0.7 in the eighties, Dumas 1986) indicates that - for a variety of reasons - there is a process of deindustrialization going on in favor of the service sector and that production loses competitiveness (cameras, cars, computerchips, machinery, machine tools, recorders being well known examples for this).

In the region of South-East Asia economically dominated by Japan, the industrial rise occurred substantially later and, in Japan, became relevant for global competition not before the reconstruction phase after World War II. In recent years it was followed by threshold countries like Korea or Taiwan with similar development patterns. Driven by the relatively large home markets, it was also based on mass production principles, but developed in a different industrial structure modified by its own specific industrial relations (Toyotism instead of Fordism, Dohse and others 1984). With well targeted campaigns, the huge advanced multibusiness companies from this region attacked their well established competitors in Europe and the USA. They normally had two economic assets at hand: lower costs and higher productivity of their production processes due to a work organization with much less division of labour and highly skilled work force, but still using economies of scale (e.g. cameras, cars low cost standard NC lathes and machining centers). Very recently, however, their successes seem to lose momentum, since the economics of production they are based on get in conflict with the requirements of competition on stagnating markets.

Although the economic region of Western Europe is very heterogeneous with respect to industrial structures, skill profiles and industrial relations, at least some general statements can be made. Its industrial core (i.e. England, FRG, Northern Italy, Sweden, Switzerland with the exception of Benelux and France being extremely different) developed along the lines of a different production paradigm. Since in this area the industrial rise was tied to manufacturing capital goods rather than consumer goods, the order bound manufacturing processes with small batch production have been dominant from the very beginning (e.g. Germany's industrial rise was founded on machinery, including machine tools, and on chemical industry; even today the production of capital goods with appr. 25 % is much more important than the already huge car industry with 17 % of total industrial production). The home markets being split among the nationalities, the core of the European industry, thus, developed a specific ability for adapting its products to the requirements of its users ("tailor made machinery") and accordingly established flexible manufacturing processes,

the productivity of which is even then ranging halfway between that of USA and Japan (see Table 1). Hand in hand with this European industrial evolution, regardless of all national differences, a more or less highly skilled work force emerged together with industrial relations setting in one way or another favourable conditions for handling the technological change in socially suitable forms.

Table 1: Annual increase of manufacturing productivity (in annual output of manufacturing per employee-hour) in USA, Japan and FRG from 1965 to 1979

USA	2.3 percent
Japan	13.7 percent
FRG	7.3 percent

(Source: Melman, 1983 p. 164)

Considering the specific strengths and weaknesses of the industrial structures in these roughly sketched triad economic regions with respect to future market requirements, the competitiveness of the Japanese industry appears to be clearly ahead of that of the USA. The much smaller extent of division of labour combined with the higher level of skill profiles keeps productivity increases comparatively high and makes it easier to cope with rapid innovation. This, at least, is valid so far as high volume production with its economies of scale is concerned and so long as this type of manufacturing will still correspond to market requirements. On the other hand, the Japanese industrial system has (yet?) only relatively little experience with highly flexible order bound manufacturing (even their machine tool industry being no exception).

With this respect, the European industrial core might potentially even be better off at least as far as those parts of it are concerned that have long experience with "flexible specialization" (Piore and Sabel 1984), an appropriate flexible production system and a skilled work force at their disposal. To the extent to which the stagnation trends on the world markets and, hence, competition by displacement prevail, Europe's comparatively favourable position tends to become even more superior, while the industrial system of the USA will be further losing production competence due to a misled technology and wasted human resources (Melman 1983).

The potential superiority can be transformed, however, into real competitive power, if and only if the decision makers at all levels become aware of this situation and realize that they have to develop future manufacturing technology, work organization and skill profiles according to the specific requirements of "flexible specialization" or, looking at high volume production, to those of "diversified quality production" (this being a hard lesson to learn for some countries and industries, of course). Instead of merely imitating Japan, it is necessary for survival to develop Europe's own manufacturing technology suited to its own needs. The factory of the future is at a cross-roads. (Brödner 1986, Piore and Sabel 1984, Sorge and Streeck 1986).

## 2. Economics of Production

-----

### 2.1 Internal Conditions of Operation:

The substantial shift on the world markets from expansion to stagnation has a strong impact on the internal conditions of operation in production processes. They now have

- o to become highly flexible with both respects alterations of products and process innovations,
- o to insure at the same time high performance of the machinery and high productivity, and to cut down lead times and work in progress,
- o to enable enlarged quality and functionality of the products.

However, the existing production structures as they have developed until today contradict these new requirements in one way or another.

According to recent results of a more systematic analysis of the relationship between technical change, work organization, skill profiles and the impact of product markets, these are loosely coupled only by some degree of affinity rather than being completely determined by each other. Neither does a given product and its market determine the technology to produce it

nor does technology determine work organization or skill profiles. Hence, there always is room for strategic choices for products, technology and work organization. The underlying decision space for alternative product strategies can be described by mainly two variables: the type of competition to which they are exposed and the volume in which they are produced. These divide production into standardized price-competitive and customized quality-competitive production on one side, and low and high volume production on the other side (see Fig. 2, Sorge and Streeck 1986).

	<i>Standardized Price-Competitive Products</i>	<i>Customized Quality-Competitive Products</i>
<i>Low Volume</i>	Specialized Component Production  <i>1</i>	Craft Production  <i>2</i>
<i>High Volume</i>	  <i>3</i> Mass Production ("Fordism")	  <i>4</i> Diversified Quality Production

Fig. 2: A simple classification of product strategies

With respect to this scheme, traditional production concepts either fall into the cell of low-volume production of customized quality-competitive goods (order bound production) or into the cell of high-volume production of standardized price-competitive goods (Fordism Toyotism). With the advent of high performance EDP the range of options for product strategies was considerably widened. Its most important impact is that the new type of high-volume production of customized quality-competitive goods (e.g. German or Swedish car industry), or in short "diversified quality production" with the potential of economies of scope has been made possible, let alone that the strategy of "flexible specialization" experiences a quantum leap towards improved rentability and competitiveness or that traditional mass production can move towards smaller batches. Although these different types of production will most probably coexist for a long time to come, the main focus of this and the following papers is on small batch production for the strategic reasons discussed above.

Past development of small batch production can be briefly characterized by three stages: In the first step labor was horizontally divided according to the concepts of Smith and Babbage making it possible to gradually use machines. In the second step Taylor's principles provided planning to be separated from executing. The third step deepened this vertical division of labour by introducing NC-machines and making programming an additional subtask of planning. Each of these have been caused by the political-economic prospects of better control of production, higher productivity and lower costs rather than by technical necessities.

The result of this is the highly differentiated job shop manufacturing process with very complex design, planning, and control tasks that we now have. This way of organizing batch production shows serious drawbacks, however, such as long and variant throughput times, an unfavourable ratio of indirectly to directly productive workers, and low quality of work (being far better than in mass production, however).

In particular, there are three substantial economic difficulties the factory of today has to contend with 1).

Firstly, there is the continual increase of the capital intensity of the factory equipment which compels the management to make better use of it (see Fig. 3).

Secondly, the very long and variant lead times caused by the functional principle of job shop manufacturing give rise to high expenses for work in progress (see Fig. 4).

Thirdly, the misled ratio of 144 indirect to 100 direct workers in the average in the German machine industry causes too high personnel expenses, since well organized firms with comparable products demonstrate that the ratio of 90 to 100 is largely sufficient.

In order to surmount these difficulties, basically two opposing production concepts have emerged being briefly characterized below (Brödner 1985).

---

1) Cum grano salis, the following data from the German machine industry seem to apply for other European countries as well.



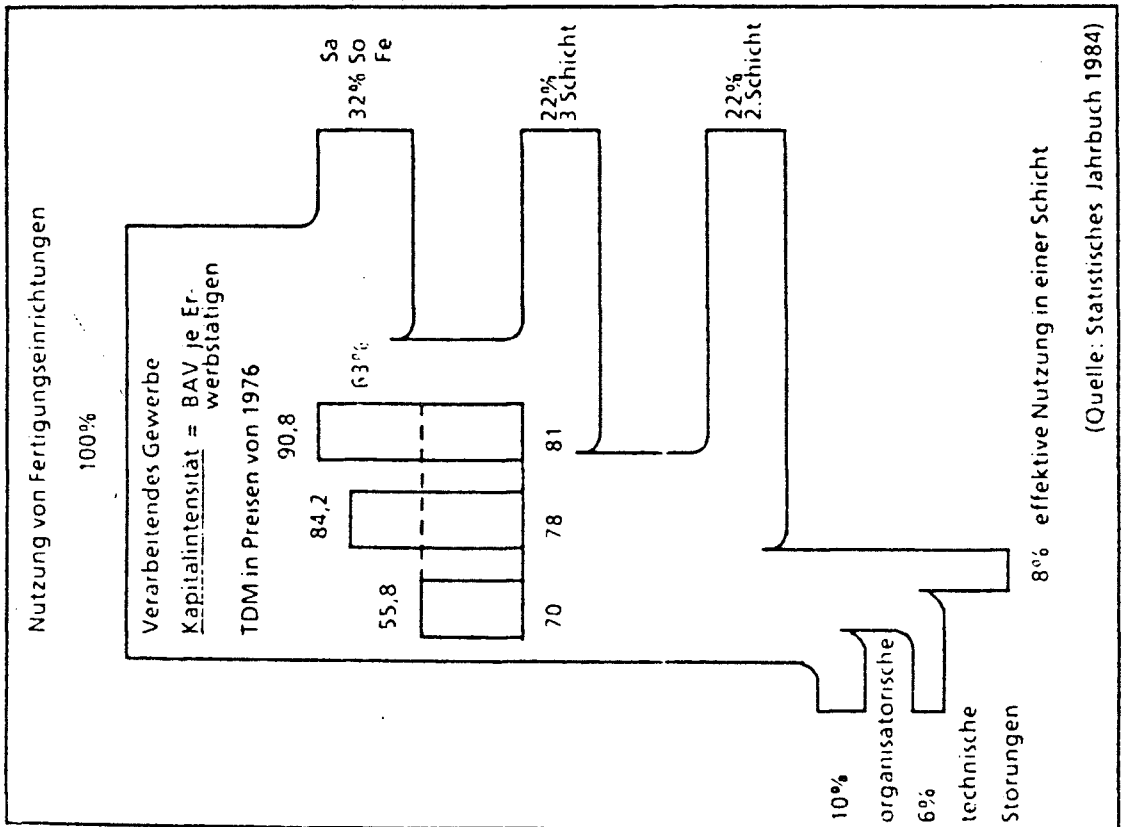

Fig. 3: Utilization of capital intensive machinery

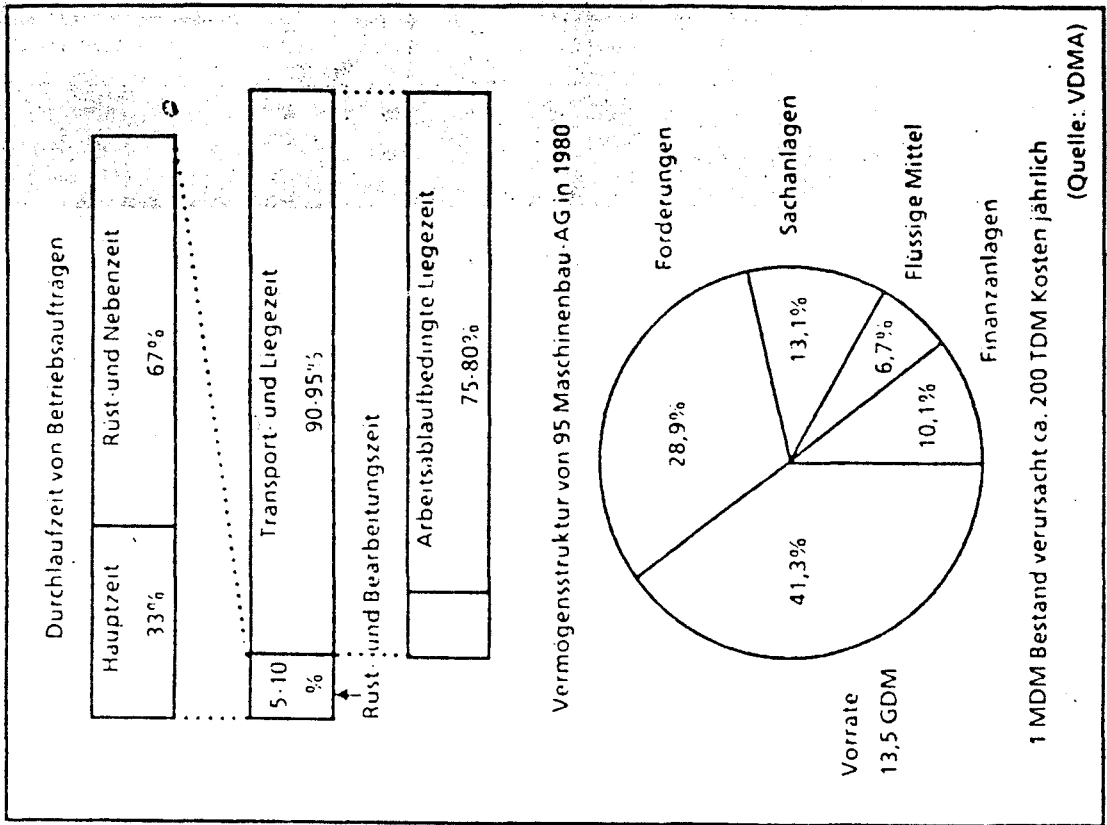

Fig. 4: Lead times and work in progress

## 2.2 The Technology Centred Approach - The "Unmanned Factory":

This approach leaves the basic job shop structure of the production process unchanged and follows the same fundamental objectives as in the past: to reduce direct labour costs and to gain better control over the production process (Sigismund 1982).

Applied to the shop floor, management attempts to almost completely automate setting and operating functions for the machine tools and handling systems. The activities focus on automatic part and tool change, measuring devices and monitoring systems. They are, of course, limited by the rapidly growing costs for this equipment. Although fully automatic operation might be temporarily possible, there still remain gaps to be filled by human operators.

The largest potential of rationalization lies in the technical office, though, where many but more or less separated attempts have already been made to automate parts of the immense information processing work (which can easily exceed half of the total amount of labour). Since the use of computers requires analytical models of the process in question, by means of which objects and sequences of work can be described as datastructures and algorithms, their application started in areas being easiest accessible or promising the largest economic effects, e.g. drafting, process planning, inventory control, and scheduling. All these systems helped a little to save time and costs, but did not improve the situation fundamentally, particularly as their separated development and application make it very costly, if at all possible, to integrate them (Sigismund 1982).

Coinciding with the broad dissimination of this kind of CAD and CAM systems, a new polarization of qualification occurs. In order to use them effectively, objects and sequences of work become extremely formalized and at the lower end the user's work loses important parts of its former competences finding new constraints by the system's formalism, while at the upper end the work of only few planning and maintaining the system's use requires broad qualification. In addition, functional differentiation leads to further division of mental labour with similar effects (Beitz 1983, Benz-Overhage and others 1984, Hirsch-Kreinsen 1984, Wingert and others 1984).

The repeated and fault intensive input of the same data in different functions demands integration of computer assistance. Due to the high degree of formalized and concreted knowledge, more functions of mental work have become accessible for computers. Thus, the present state shows the necessity as well as it holds the prerequisite to create a computer integrated manufacturing (CIM) system. It has to comprise at least three basic devices:

- a common data base with which all functional programs may interact, since most data are used in several functional areas,
- a data highway to link subsystems, since a CIM system will be widely distributed,
- data exchange interfaces, since both users' and suppliers' demands require to be able to link subsystems of different origin.

Integration is not the only issue of the technology centered strategy, though. Others are to create knowledge based and expert systems for use in all key areas of production in perspective of the coming of fifth generation computers. There are mainly two motives behind this: one is the management's fear that - as most human labor has been reduced to low grade functions except for a few high grade experts - conventional programs might not be able to cope with complex and changing situations; the other one is its wish to have the expensive human experts' knowledge at its own disposal. Although this development is accompanied with great hopes stirred up by the "artificial intelligence" community (Feigenbaum and McCorduck 1985), it is rather questionable whether it will ever achieve what it promises (Dreyfus 1979).

At the end of this far reaching development an integrated computer system on the one hand and a dismembered work structure on the other will be found. Most of the production knowledge will then be incorporated in the computer system, while the workers' qualifications will waste away, since they are not used any longer.

The concept of the "unmanned factory" runs into several severe difficulties, however, letting its success appear to be rather questionable.

Firstly, the extremely high expenses and risks, especially caused by the software needed, get in conflict with the financial power of the many small and medium sized firms. Despite their growing economic importance, they would be bypassed by the development.

Secondly, firms following this strategy would suffer from relative inflexibility with both respects alteration of batches and process innovation. This is due to the fact that every change of a customer order or of a piece of production equipment has first to be modelled in the computer system. In the long run the firm might even lose its innovative capability, since production knowledge and creativity on the human side have been wasting away over time. All this is in contrast to market requirements.

Thirdly, existing skills (especially in Germany a very important resource) would be rejected, while skills which do not exist would be required. In order to avoid these difficulties, it seems necessary to look for an alternative approach.

### 2.3 The Human Centred Approach - Skill Based Manufacturing

The human centred approach is based on completely different principles of organizing small batch production. By splitting orders instead of dividing labour, job shop manufacturing with its fundamental drawbacks can be changed into group manufacturing where part families are manufactured in their entirety.

Group technology principles can be implemented in four major stages according to the main organizational aspects shown in Fig. 5 (Ahlmann 1980, Mitrofanow 1980, Warnecke and others 1980, Williamson 1972).

In many cases management feels content with structuring the firm's entire part spectrum into part families (first stage) only in order to gain more transparency and better classification for the geometric and manufacturing data pools (drawings, part lists, process plans). However, the idea of group technology obviously denotes a general organizational concept rather than a single technique.

If the organizational changes are restricted to the application of the first principle alone, the economic effects that can be achieved at all are by far not exhausted. On the contrary, it can be expected from experience with realized cases that major advantages are achieved but by advancing to the higher stages of group technology. As compared to job shop manufacturing, these advantages can be characterized as follows (Ham 1977, Spinass and Kuhn 1980, Warnecke and others 1979, Williamson 1972)

- short throughput times (time reduction by 60 to 88 percent and benefits of 44 to 60 percent for in-process inventory have been reported),
- rich job content and wide margins of action (reducing stress and challenging the worker's skills),
- easy production planning and control (since each production insula can be regarded as a single uncoupled unit).

The main deficiency is the unbalanced utilization of machining capacity. However, this can be mitigated in its economic effects if capacity requirements are oriented at full load of the most expensive piece of equipment and if limited cross utilization of idle capacities between production insulas is allowed. The extra costs for higher qualification of the whole working team as compared to specialized workers is easily compensated by the other benefits of group manufacturing. Beside of these main advantages considerable reductions of set-up times and improvements in overall engineering and productivity give rise to further benefits.

In a similar way as it has been demonstrated for the manufacturing process on the shop floor (where the knowledge exists how to make machines), these organizing principles can also be applied to the design office (where the knowledge exists how to invent machines). The design process being split up according to families of products, or their modules, the designers (single or in team work) perform the whole design process comprising tasks as finding the functional structures and the dimensions, calculating, single part design or geometric modelling. Thus, mainly two skill centered production subsystems equipped with local computer assistance and connected by electronic data exchange will be formed: production and design insulas.

In order to work efficiently, these widely autonomous subsystems still need some data exchange and so they have to be interlinked by the basic components of the CIM architecture, i.e. a common data base, a data highway, and data exchange interfaces (Fig. 6). However, the way how computer assistance is implemented differs completely from the technocentric approach. Instead of concreting and incorporating almost all knowledge and the sequences of work as far as possible in the computer system, in this case the computer serves as a general, actual, and consistent information system also performing routine operations, but leaves the planning of working actions to the workers' and designers' skill (these might even implement their own tools).

Although lacking room for more detailed analysis, a substantial increase of productivity being expected from both production concepts must be stated. Many indications suggest that productivity grows even faster when following the human centred development path. Paradoxically, production requires the less quantity of labour, the more it uses its quality. This implies a strong impact on employment in general and on the structure of labour markets in particular, especially since the required high level of skill profiles tends to further segmentation trends. Therefore, combined counteractions on both firm and society level have to be developed (appropriate skill formation for all, reduction of working hours, etc.) in order to avoid a segmented work force and unemployment (Brödner 1985).

### 3. Knowledge of Production

---

Independent of the type of production, it is peculiar to a working subject to have a conception of acting in mind before actually doing something. This changeable acting scheme, in turn, is generated from the worker's internal representations of both his acting and the effects on the object he created. It thus becomes concreted experience.

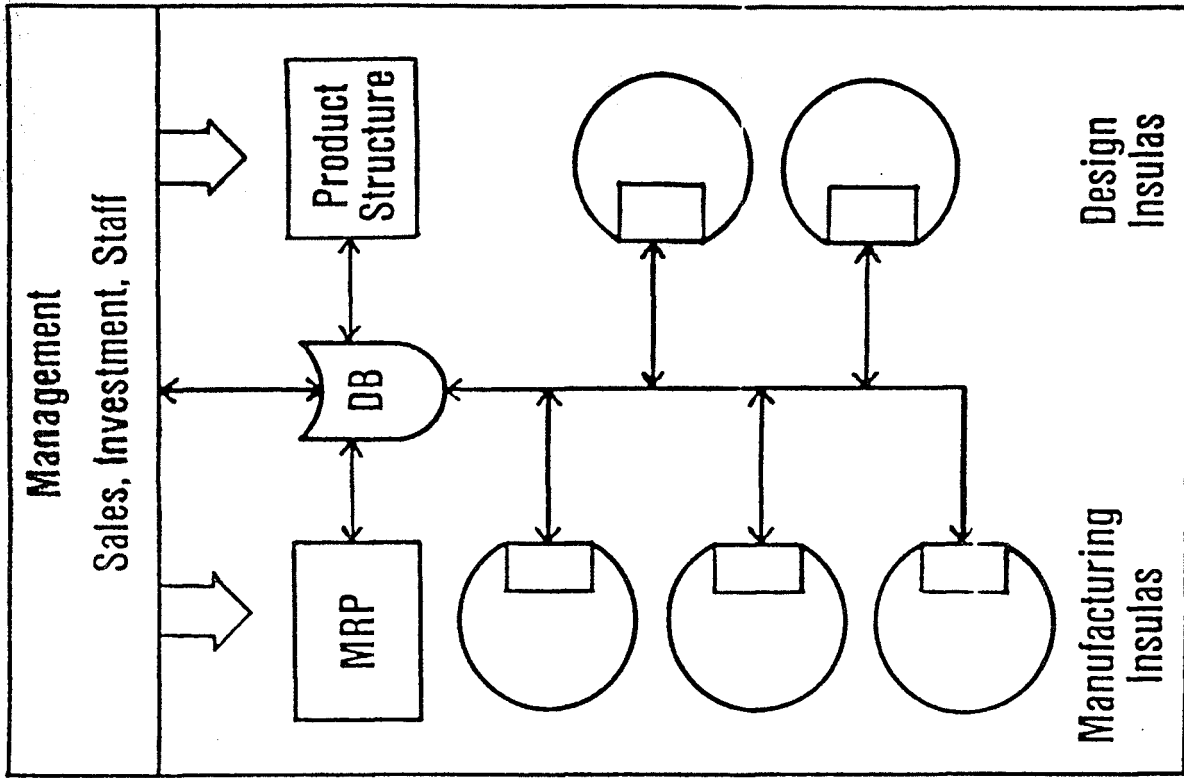

Fig. 6: Integrated group manufacturing

	<p><b>1. Stage: Part Family</b> Parts with similar manufacturing requirements (grouping parts)</p>
	<p><b>2. Stage: Manufacturing Facility</b> Equipment needed for completely manufacturing a part family (grouping machinery)</p>
	<p><b>3. Stage: Working Group</b> Equally skilled workers cooperating to completely manufacture a part family by appropriate equipment (grouping personnel)</p>
	<p><b>4. Stage: Production Insula</b> Integration of design, planning and controlling tasks for complete production of a part family (organizational grouping)</p>

Fig. 5: Principles of group technology

During his active engagement in the world surrounding him, the worker perceives those objects and, by seizing them and acting with them, he conceives their function and realizes the mode of action, in short, he forms their conception. By acting repeatedly in similar situations, he may happen to abstract from the specific reality and to recognize the general in the specific. Thus, he is able to generalize his acting scheme and to objectify his experience in the form of language, tools and machines (Volpert 1984).

By conceptual analysis of his acting, the worker is able to construct an abstract model of his generalized actions comprising the objects and the rules to change them. Hence, machines are nothing else than implemented theory. However, the prerequisite for being able to do so is that he recognises the recurring factors in the changing situations. Unless he realizes the general in the specific, the experience he has gained is private to him. Due to this "tacit knowledge" (Polanyi 1966), there exists a barrier to objectifying the production knowledge, which cannot be surmounted but by empirical and theoretical analysis within certain limits, i. e. production processes can in principle not be completely modelled.

On the other hand, the acting subject perceives, due to his sensitive body, in the situation he is in any change of his surrounding world, that has been growing with him while being engaged in it, as a whole and not as elements that have to be fitted by rules. He, therefore, knows to act goal orientedly even in uncertain or in unstructured situations. His concreted experience or "tacit knowledge", which is much more comprehensive than the rule based or objectified knowledge being the only one that can be implemented in machines, forms the basis for the unique human strength to be able to conceive and evaluate complex situations, to make adequate decisions and to take appropriate actions.

While humans, thus, can act creatively in an unknown surrounding, proceeding unsystematically and inconsistently, however, owning a not very impressing information processing capability, machines are bound to programs made by humans in order to change their state and to operate on data structures working rule based and consistantly, of course. In order to join these opposing attributes of humans and machines productively, some basic principles have to be regarded corresponding to the hierarchical system of design criteria shown in Fig. 7 (Hacker 1978).



Work design, i. e. the determination of the division of labour, of the partition of functions between man and machine and of the modes of man-machine interaction (see the layers in Fig. 8) has to be done in such a way, that in the working situation a wide margin of action is being preserved leaving initiative, evaluation and decisions up to the worker and that his work comprehends planning and executing tasks. So that in this situation the computer can be used as a tool, its functions and its behaviour have to be completely transparent. Particularly, its reactions have to be self explaining and adapted to the actual working situation. In interaction it is extremely important that the worker can perceive the connection between his own intention or action and the effects it produces.

Accordingly, an appropriate user surface of the technical equipment is needed. The man-machine interaction therefore has to be designed in a way that it is

- transparent and self explaining (by use of direct object manipulation),
- adjustable to different degrees of user's experience (presenting flexible dialogue procedures),
- reliable (following the principle "what you see is what you have got").

Besides this, the terminals and screen masks have to show correct ergonomic shape. Looking at existing CAD/CAM systems, most of these conditions are not fulfilled or to an unsatisfactory little extent only.

Judgement level	Sub-levels	Possible criteria (examples)
Personality promotion ↑	<ul style="list-style-type: none"> <li>● raising the skill</li> <li>● preserving the skill</li> <li>● de-skilling</li> </ul>	<ul style="list-style-type: none"> <li>● margin of action</li> <li>● learning activity required</li> </ul>
Lack of impairment ↑	<ul style="list-style-type: none"> <li>● no impairment</li> <li>● reduced effectiveness</li> <li>● functional disturbance</li> </ul>	<ul style="list-style-type: none"> <li>levels of psychic or physical stress effects (e.g. monotony, overload, saturation, shiftwork)</li> </ul>
Lack of damage ↑	<ul style="list-style-type: none"> <li>health damage</li> <li>● excluded</li> <li>● possible</li> <li>● very likely</li> </ul>	<ul style="list-style-type: none"> <li>● standard values of detrimental environmental influences (noise, lighting, climate, toxic substances)</li> <li>● danger of accident</li> </ul>
Practicability	<ul style="list-style-type: none"> <li>minimum requirements</li> <li>● kept</li> <li>● partially undercut</li> <li>● mostly undercut</li> </ul>	<ul style="list-style-type: none"> <li>● anthropometric standards</li> <li>● sensing capabilities</li> <li>● psychic capabilities</li> </ul>

Fig. 7: Hierarchical system of work design criteria

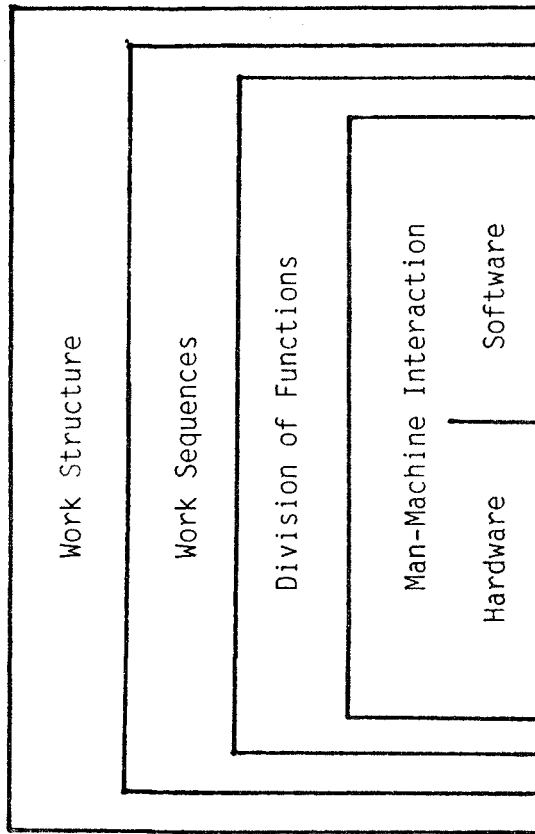

Fig. 8: Work design layers for computer aided work systems

#### 4. Politics of Production

---

History of industrial production is, at the same time, a history of the manifold attempts of the management to get control over production processes. At the very beginning of the first industrial revolution, when craftsmen were hired to work under the unified command of a capitalist owner, they still worked in exactly the same manner as they were used to. Since all knowledge of production was at their disposal alone, the owner completely depended on their good will to produce something with the required quality.

Seen with the owner's eyes, this was a very unsatisfying situation establishing a substantial problem in capitalistic production, however. It is true that, by force of the working contract, he owned the working capacity, but that did not determine the material form, in which the work was actually being done or the working capacity was productively used. Since the productive forces, the abilities to produce or create something are not separable from the working subject, whose abilities are not alienable, the owner is compelled to cooperate with the worker. This is the basic reason for the issue of politics of production.

The owner's situation could only be improved by modifying the modes of manufacturing. The first big attempt to get more control over production was the horizontal division of labour proposed by Adam Smith. Besides the economic benefits of more output with less costs he had in mind as basis for the "wealth of nations", the workers' specialization on specific tasks within the working process had the effect that they lost, as time went by, most of their production knowledge in favour of the entrepreneur, who was now able to set the basic manufacturing structure (Marglin 1977).

In general, the horizontal division also was the basis for introducing machines in manufacturing. The always recurring same operations the workers had to perform could be easily analysed and conceptually modelled and, thus, be objectified in machines. Besides the increased work performance caused by the use of machines, they again contributed to solve the issue of better control over production "One great advantage which we may derive from machinery is from the check which it affords against the inattention, the idleness, or the dishonesty of human agents" (Babbage 1835).

In spite of the horizontal division of labour and the limited use of machinery, control over production still remained full of gaps, since within the frame of divided labour the workers could act autonomously. This was the edge where Taylor stepped in and established his "principles of scientific management". By profound empirical analysis of the workers' operations and of cutting metals, he became able to objectify essential parts of the production knowledge and, thus, to separate planning from executing tasks. Managers were now able to plan working processes independently from the workers and to prescribe them, how and in what time they had to perform their operating tasks. Later on, the introduction of partly automated machinery and of computer systems in manufacturing (Fordism in mass production, NC technology in small batch production, CAD/CAM systems) even enlarged the potential of control over production in the hands of managers.

This development has its price, however. Manufacturing processes are becoming more and more inflexible to the extent to which the workers' autonomy and production experience are declining. This appears obviously in mass production that has been explicitly designed for single products with few variants, eventually. But it also holds for small batch production, where Taylor's principles could be applied only halfway and produced its unfavourable structures (job shop manufacturing with a skilled work force despite of central planning) considered earlier. Both types of manufacturing processes, the inflexible mass production and the hybrid small batch production being partly Taylorized, partly based on skilled work, are getting into conflict with the new requirements of global competition. High flexibility of manufacturing is incompatible with deskilling and constraining autonomy of the workers. Hence, new production concepts with altered politics of production and alternative forms of controlling production are needed.

The principles of group technology and autonomous working groups provide such a production concept. Yet, the autonomy of production and design insulas can only be developed within the limits leaving the management without fear to lose control over production as a whole. Control changes its form, of course. According to the technology centred production con-

cept it used to be exercised by objectifying knowledge, by the detailed working instructions derived from it, and by the machine system. In contrast, it is now exerted through computer assisted central planning and supervising of production in its entirety, but leaving much wider margins of action to local planning and execution, and through a performance policy challenging the workers' competence, autonomy and responsibility as well (Kern and Schumann 1984). Controlling autonomy instead of defeating independence is the issue.

##### 5. Conclusion: The Superior Choice

-----

Taking all these considerations together, it becomes obvious that we are in a situation of choice. Different strategic options for computer integrated manufacturing are at hand. They deliver different economic benefits, of course.

Taking the problems into account the technology centred approach is going to run into, the human centred one clearly shows its superiority with both economic and human respects, especially under disturbant market conditions. It reduces throughput times dramatically (with a huge potential for saving costs and gaining market strength) and it is less capital intensive above all on the software side, since existing qualifications are essentially preserved and not replaced by programs causing high expenses. For the same reason production gets very flexible, particularly since changes of orders or processes can be considered without being modelled first. Working conditions allow for wide margins of action and enhancement of skills, thus preserving the innovative capability. It can be implemented stepwise and hence also be followed by smaller firms.

There are strong forces of inertia, though, hindering the human centred approach to disseminate fastly. They result from a firm's hardware, software, social system, and prevailing ideology. While hardware seems to have the weakest inertia and software already needs fundamental changes, the social system and ideology establish the highest barriers. Since the transition to group manufacturing deeply influences social positions and relations, it can only be performed on the basis of a bargained and agreed strategy. To establish such a strategy, the prevailing thinking has first to be overcome that cannot imagine any other improvements of production than replacing human capabilities by machine artefacts.

## REFERENCES

- Ahlmann, H.-J., Fertigungsinseln - eine alternative Produktionsstruktur, Werkstatt und Betrieb 113 (1980) 641-648.
- AWF (Ed.), Flexible Fertigungsorganisation am Beispiel von Fertigungsinseln, Ausschuß für Wirtschaftliche Fertigung e.V., Eschborn, 1984.
- Beitz, W., Entwicklungszwänge für den Konstruktionsprozeß, in Produktionstechnisches Kolloquium Berlin, PTK '83, Hanser, München, 1983.
- Benz-Overhage, K., Brumlop, E., von Freyberg, Th. and Papadimitriou, Z., Neue Technologien und alternative Arbeitsgestaltung, Campus Verlag, Frankfurt, 1984.
- Brödner, P., Fabrik 2000, Alternative Entwicklungspfade in die Zukunft der Fabrik, edition sigma, Berlin 1985
- Brödner, P. (Ed.), Skill Based Automated Manufacturing, Preprints of the IFAC Workshop held in Karlsruhe, Sept. 3 - 5, VDI/VDE-GMA, Düsseldorf, 1986
- Dohse, K., Jürgens, U. and Malsch, Th., Vom "Fordismus" zum "Toyotismus"? Die Japan-Diskussion in der Automobilindustrie, Wissenschaftszentrum Berlin, IIVG/pre 84-212, 1984
- Dreyfus, H.L., What Computers Can't Do. The Limits of Artificial Intelligence, Harper & Row, New York, 1979.
- Dumas, L.J., The Overburdened Economy, Univ. of California Press, Berkeley, 1986
- Feigenbaum, E.A. and McCorduck, P., The Fifth Generation, Addison-Wesley Publishing Comp., Reading, 1983.
- Hacker, W., Allgemeine Arbeits- und Ingenieurpsychologie, Hans Huber Verlag, Bern, 1978.

Ham, I., Group Technology Applications for Computer Aided Manufacturing, NC/CAM-Journal (1977) 17-22.

Hirsch-Kreinsen, H., Organisation mit EDV, .G. Fischer Verlag, Frankfurt, 1984.

Kern, H. and Schumann, M.: Das Ende der Arbeitsteilung? Rationalisierung in der industriellen Produktion, C.H. Beck Verlag, München 1984.

Köhler, C. and Schultz-Wild, R., Flexible Manufacturing Systems - Manpower Problems and Policies, in Proceedings of World Congress on the Human Aspects of Automation, Ann Arbor, 1983.

Marglin, S.A., Was tun die Vorgesetzten? Ursprünge und Funktionen der Hierarchie in der kapitalistischen Produktion, Technologie und Politik, Bd. 8 Rowohlt, Reinbeck 1977

Melman, S., Profits without Production, Knopf, New York, 1983

Mitrofanow, S.P., Wissenschaftliche Grundlagen der Gruppentechnologie, VEB Verlag Technik, Berlin, 1980

Piore, M.J. and Sabel, Ch.F., The Second Industrial Divide. Possibilities for Prosperity, Basic Books, New York, 1984

Polanyi, M., The Tacit Dimension, Doubleday Comp., Garden City, 1966

Sigismund, Ch.G., The Structure and Strategy of Factory Automation, Research Report 661, Business Intelligence Program, SRI International, Menlo Park, (1982).

Spinas, P. and Kuhn, R., Gruppentechnologie. Ein alternatives Fertigungskonzept, Report, Lehrstuhl für Arbeits- und Betriebspsychologie der ETH Zürich, (1980).

Sorge, A. and Streeck, W., Industrial Relations and Technical Change: The Case for an Extended Perspective, Workshop on "Coping with New Technology in Japan and the Federal Republic of Germany", Berlin, August 29 - 30, 1986

Ulich, E., Frei, F. and Baitsch, C., Zum Begriff der persönlichkeitsförderlichen Arbeitsgestaltung, Zeitschrift Arbeitswissenschaft 34 (1980) 210-213.

Volpert, W., Maschinen-Handlungen und Handlungs-Modelle - ein Plädoyer gegen die Normierung des Handelns, Gestalt Theory 6 (1984) 70-100.

Warnecke, H.J., Saak, V. and Häussermann, S., Gruppentechnologie und Fertigungszellen, wt-Z. ind. Fertig. 69 (1979), 164-166.

Warnecke, H.J., Osman, M. and Weber, G., Gruppentechnologie, FB/IE 29 (1980) 5-12.

Williamson, D.T.N., The Anachronistic Factory, Proc. R. Soc. London, A331 (1972) 139-160.

Wingert, B., Duus, W., Rader, M. and Riehm, U., CAD im Maschinenbau, Springer Verlag, Berlin, 1984.







Rainer Schultz-Wild

INSTITUT FÜR SOZIALWISSENSCHAFTLICHE FORSCHUNG E.V.,  
Munich, F.R.G.

**TRANSFORMATION CONDITIONS OF FUTURE FACTORY STRUCTURES:  
TECHNOLOGY, ORGANIZATION, EDUCATION AND VOCATIONAL TRAINING**

Contents

1. Future Factory Structures and Interests in Process-Related Utilization of Skills and Qualifications
2. Preconditions for a Process-Related Utilization of Skills and Qualifications
3. The Part Played by Education and Training in the Development of Future Factory Structures

Literature

This paper was written after completion of the studies commissioned by FAST and CEDEFOP entitled "New Production Systems", as well as in connection with the research project "Integrative Utilization of Computer-Aided Technology and Qualification Structures Within Mechanical Manufacturing" being carried out since 1984 at the ISF-Munich and supported by the Federal Ministry for Research and Technology via the Projektträger Fertigungstechnik in Karlsruhe. The author would like to thank his team colleagues from the ISF, particularly Hartmut Hirsch-Kreinsen and Christoph Nuber for their helpful suggestions and feed-back.

## **1. Future Factory Structures and Interests in Process-Related Utilization of Skills and Qualifications**

---

In all likelihood uniform factory structures will not exist in Europe in the near future: Too great are the differences with regards to basic conditions and developmental perspectives between regions, countries, economical branches and market conditions, as well as the differences concerning the problems and potential solutions in the area of production technology and also the workforce and skill availability etc. Even if the production technology offered does tend to become more uniform due to market conditions and/or international standardization efforts, and differing working conditions begin to converge due to government and international compensation policies, and lastly even if perhaps certain adaptation processes will take place within education and training systems, it nevertheless remains highly doubtful that questions of technology utilization, work organization and the division of labour within companies and between companies will in all regions be solved according to a uniform structural pattern, regardless of whether it is the case of a small company with a narrow regional market in one of the industrially developing countries of the Common Market or that of a large scale mass production enterprise in one of Europe's industrial centres.

It is widely agreed upon among experts that the concept of the so-called unmanned factory has only very limited chances within the near future and that this concept is, at best, suitable only for certain marginal areas of highly standardized manufacturing. Secondly, there are also numerous voices stressing the limitations of the long prevailing Tayloristic or Fordistic model of manufacturing organization and work structuring, strongly centralized and based on a strong division of labour, particularly within the context of the utilization of modern computer-aided rationalization technologies and the necessity for adapting to rapidly changing market conditions (compare for example Brödner 1985; Piore, Sabel 1984; Warnecke 1985).

In view of these factors, particularly with regards to European industry, factory structures are being advocated which make use of the existing wealth of skills and qualifications and which seek to secure the potential for innovation and the capability to adapt, particularly in the case of the often smaller and medium size companies, by preserving the scope for taking action and decision making in proximity to the basis of the manufacturing process, on the shop floor. Such concepts are less oriented towards maximum utilization of computer-based automation technology up to the total exclusion of human labour, but on the contrary aim for a combination of technology and labour, whereby the production knowledge and experience held by workers closely involved in the manufacturing process is systematically integrated.

The process-related utilization of skills and qualifications offers companies a number of advantages<sup>1)</sup>, particularly when strategies of so-called "hard" automation with their standardization requirements concerning the product and remaining human labour meet with restrictions and therefore strategies of flexible automation are to be pursued instead:

- o Process-related utilization of skills and qualifications can save planning costs and other investments for complex and extremely expensive automation technologies in the areas of hard- and software when workers are able to bridge gaps in the process sequence.
- o Process-related utilization of skills and qualifications permits saving implementation costs as well as a comparatively rapid introduction of technological-organizational innovations to the manufacturing process. When extensive basic skills already exist on the shop floor level, the introduction of new

---

1) On the advantages of the utilization of qualified skilled workers in complex manufacturing systems compare Asendorf, Nuber 1986.

technology components will lead to less qualification deficits, thereby resulting in a considerable reduction of training expenditures on the one hand, while on the other the implementation work performed by the user company's workforce shortens the running-in period of the new facilities and will make them operating productively at an earlier date than otherwise.

- o In view of the continuously high costs for components of computer-aided flexible automation the fact that the process-related utilization of skilled labour can reduce the risks and duration of system failures is of particular significance. The utilization of qualified, skilled workers familiar with the specific manufacturing equipment increases the latter's availability and reliability. Such personnel can not only prevent disturbances by intervening and correcting the ongoing manufacturing process, but also shorten breakdown times by performing repairs faster due to the fact that specialized maintenance personnel need not be called upon and waited for.
- o Moreover, the process-related use of skills can also permit a better utilization of manufacturing equipment, not only with regards to the extent of operational flexibility for various products or product variants within the framework of the given technical corridor, but also in terms of coordinating machine schedules and/or production capacity with the requirements of the ongoing production flow.
- o Finally, the process-related use of skilled personnel in the production process can also result in lower labour costs. On the one hand this refers to the savings in costs arising outside of the immediate area of manufacturing for technical services like work planning, programming, manufacturing control, maintenance and quality assurance, when a more centralistic manufacturing organization is given. On the other hand, the number of workers can be reduced compared to highly specialized forms of work organization, or those aiming for a mini-

mization of the use of skills, because broadly skilled workers are able to replace each other and fill vacancies caused by illness or other reasons.

All of these reasons point to a company interest in making use of a skilled and qualified workforce who is familiar with the special requirements of flexible automation and in employing these workers in the immediate proximity of the manufacturing process and of the mostly complex manufacturing equipment. In terms of manufacturing organization widely differing solutions are conceivable with this strategy, starting with more traditional workshops specialized in certain manufacturing technologies, up to production islands for the complete processing of products or components of a final product. The forms of work organization and the division of labour can also vary, for example between the following two basic models:

- o In the first case the traditional forms of job classification and hierarchical division of labour are dispensed with to a large extent and instead, a homogenous group of equally qualified production workers are employed who share the various and changing work tasks within a given manufacturing area according to internal agreements and who also share the responsibility for the fulfillment of the assigned jobs. For example, employees of the type of the German skilled worker, having practical and theoretical production knowledge and experience and having had further training in the field of information systems and control technology are suitable for this form of group work.
- o The second model adheres more to the traditional forms of functional and hierarchical division of labour and the different specialized jobs thereby resulting. Accordingly the workforce structure is differentiated depending on the areas and also the extent to which individual workers are qualified, and the utilization of personnel is more strongly arranged according to forms of cooperation between differently specialized workers. In this case a mixed staffing of a production team is

conceivable, with semi-skilled and skilled workers, technicians and even engineers, and associated with a more strongly hierarchical distribution of responsibility as well as - compared to the other model - a considerably restricted capacity for employees to replace one another if need be.

Both models, between which various graduations and numerous concrete design forms are imaginable, are in varying degrees suited to different forms of technology utilization and requirements of manufacturing processes. The first model, for example, makes far greater use of the scope for the design of work organization given within modern manufacturing technology when the binding of work tasks to the machine's operational cycle is largely reduced due to the automation of workpiece handling and transport. The second model seems to possess more advantages in those cases where automation gaps must be bridged by routine activities or where the deployment of specialists is imperative for one reason or the other. These latter forms of organization, however, also hold higher risks of a polarization of skills and the creation of permanent barriers between different employee groups.

## 2. Preconditions for a Process-Related Utilization of Skills and Qualifications

A common characteristic of the two models of work structuring previously described is the fact that they both increase "shop floor autonomy" by means of process-related use of qualified employees and reduce the significance of planning, control and supervising departments outside of the manufacturing area as opposed to the more centralistically oriented Tayloristic/ Fordistic factory structures. Both models correspond to a development concept which is currently being discussed not only in



Europe but also in the U.S.A. under the heading of "The Factory within the Factory"<sup>1)</sup>, the intention of which is underlined by the demand "CIM only with HIM"<sup>2)</sup>. The realization of such forms of manufacturing structures and work organization depends, however, on a number of preconditions. We shall briefly mention the market developments with regard to the computer-aided components of manufacturing presently offered (1), the implementation processes of new manufacturing technologies taking place within the companies (2), the availability of different qualifications and skills for manufacturing work as well as the question of gratification systems, career patterns etc. (3).

(1) In the past years the spectrum of components for computer-aided integration offered by the market has expanded considerably. This holds true for production planning functions (CAD, CAP) as well as for production scheduling and control (PSC) and manufacturing-technological functions of machine control, tool management, workpiece handling and transport and also quality assurance (compare the individual CAM-components: CNC, DNC, FMC, FMS, CAQ etc.)<sup>3)</sup>.

In many cases the use of computer-aided integration technology is characterized by a kind of pioneer situation in which the manufacturers adapt the systems' actual design to meet specific customer requirements to a considerable degree. However, there

---

1) Compare, for example, the paper by Peter R. Everitt 1985: The Manufacturing Cell "A Plant Within A Plant".

2) "Computer Integrated Manufacturing only with Human Integrated Manufacturing" - was how, at the international CIM-congress during the Systec '86 in Munich, a leading executive of a German machine building company paraphrased the demand presently being voiced to give more consideration than previously to the changes in the working situation of the employees affected when planning and introducing new technical systems (compare Hummel 1986).

3) Unfortunately the use of terminology is by no means uniform with regards to the individual CIM-components. See AWF 1985 for an attempted clarification relating computer use to certain process functions. See also Lay's paper on CIM-strategies in this volume.

is an increased development of marketable, more standardized offers requiring the system users themselves to adapt to a certain extent if considerable costs for "tailor made" solutions are to be avoided. Moreover, in many areas in which computer-aided integration technologies are applied one can safely state that the manufacturers control the market, this having to do with specific aspects of information-technological products, the expensive development of the generally very complex software solutions as well as the lack of competency in information technology on the part of the users.<sup>1)</sup> Thus it is of particular importance which organizational concepts are quasi passed on to the user companies in terms of manufacturing and work organization.<sup>2)</sup>

Complete offers of factories with fully integrated computer technology hardly exist to date. But the CIM-components on the market can be classed as those which are more open in terms of manufacturing organization and work structuring, or those which contain strongly centralistic concepts which aim for a definite division between work executed on the shop floor and the functions of planning, control and supervision elsewhere.

o In many cases computer-aided production scheduling and control systems (PSC)<sup>3)</sup> follow a strongly centralistic-deterministic design as far as their inner logic is concerned and they aim for the most exact short term detailed planning of shop floor activities possible. On the other hand, there are PSC-concepts which dispense with detailed work guidelines and regulations from the start and instead provide only central framework planning<sup>4)</sup> which is then to be worked out in detail on the shop floor level and carried out there subsequently. This second concept is more strongly based on process-related decisions in the shop floor area and thereby permits a greater

---

1) Compare for this and in the following, Hirsch-Kreinsen 1986 particularly p. 31 ff.

2) See also Brazyk's argument in this volume about "prescriptions" on work organization and skills embodied in production technologies.

3) Also referred to as computer-aided production management (CAPM) - see Lay within this volume.

scope for the design of work organization - from the use of a central control post for the execution of planning processes up to the management of manufacturing control functions by workers employed in the actual area of manufacturing.

- o The concepts according to which DNC-systems are layed out can be based on a strong division of labour and result in a concentration of informing and supervising data in the work planning department, or else concepts can be realized according to which the DNC-computer acts more as a data bank for NC-controlling and programming systems, which also allows shop floor programming to be carried out.
- o Also in the case of CAD/CAP or CAD/CAM systems one can differentiate between concepts which from the start are either office oriented and aim for more efficiency in the area of pre-planning, including office programming, or such concepts which are more shop floor oriented whereby construction data are transmitted to a workshop computer or individual CNC-control system, in order to facilitate or accelerate the programming process there.

The results of our analysis point to a present market dominance of CIM-components of a centralistic-deterministic nature which are exerting a strong influence towards a consolidation or an increase of the hierarchical-functional division of labour between the areas of planning and execution. Such solutions are usually developed and offered by large computer manufacturers who have a strong market position and are backed by many years of cooperation with the users of their systems. But it is doubtful if these solutions meet the special needs of smaller and medium sized companies.

In opposition to this stand the offers usually coming from smaller software or machine building companies which are more open in terms of work organization and do not restrict their users so strongly to pursuing certain solutions of technology integration as far as manufacturing and work organization are concerned and which are therefore more compatible with forms of process-related planning, control and supervision.

Although even in the cases of more strongly centralistic-deterministic solutions one cannot say that the user companies are being definitely bound to certain forms of manufacturing organization and work organization, it is nevertheless undeniable that the logic inherent in such solutions will influence the decisions concerning the implementation process within the company. A process-related utilization of skills and qualifications is easier to realize or maintain, when hardware and software components are designed so as to grant access from the shop floor. In this context it is interesting to note that recently there are indications that the development of systems which started out with different basic concepts is beginning to converge. However this is likely to prove to be a very longterm developmental process.<sup>1)</sup>

(2) In spite of the factors of influence built in the preformed market offers of CIM-components, there undoubtedly still remains considerable scope for the design of manufacturing organization and work organization which is at the disposal of the user companies. The question remains however, as to whether and in what way this scope for decision making is actually made use of during the course of implementation processes.<sup>2)</sup> In spite of the fact that the discussion among managers and engineers concerning the importance of "human factors" for the successful introduction of new technologies has been given more emphasis during

---

1) This can be observed in the development of NC-programming methods. It can be assumed that due to the further development of interactive-graphic programming methods a standardization of operator modi will take place between systems originally based more strongly on office programming and those oriented on workshop programming. Compare v. Behr, Hirsch-Kreinsen 1987. Generally the concepts of open system architecture seem to suit better to the manifold technical and organizational conditions of different users and open up market opportunities specially for smaller supplier companies.

2) For a more detailed report of the relevant constellations and interests in the course of company implementation processes see Hirsch-Kreinsen, Schultz-Wild 1986b. Compare also Schultz-Wild 1986a.

the past years, it can, on the basis of present experience, hardly be assumed that work organization and manpower utilization will enjoy the same careful preplanning as is the case with the technical and economical factors on which decisions are based. Many implementation processes are characterized by a step by step introduction of new technology components whereby the existing manufacturing structures and forms of organization are retained to the greatest degree possible. For the most part changes remain limited to what is absolutely imperative from a technological point of view. Such tendencies towards a sort of structural conservatism stand in opposition to the experience that especially technical innovations often initiate or are the medium of a reorganization of work processes, the extent of which can be of a more far-reaching nature beyond the actual individual innovation case. Changes of a slower and more subtle kind may possibly occur which lead to a gradual undermining of forms of work dominant so far, while radical structural changes may also be brought about. The probability of the latter arises

- o with the size of the automation leap of a given technological innovation, thereby necessitating a reorganization and extensive redistribution of work between machinery and manpower;
- o with the degree in which the previously dominant forms of modernization by small steps is deviated from or must be abandoned, for example due to the more system oriented character of the new integration technologies being installed;
- o according to the extent in which the new technologies contain concepts of work organization which contradict the principles having so far prevailed.

Process-related utilization of skills and qualifications can thus hardly be expected in those cases where control and production systems of a more strongly centralistic-deterministic type are integrated into centralistic company structures based on a strong division of labour. A process of this kind strengthens the control and supervision departments outside of the actual

manufacturing area and leads to a further reduction of autonomy still existing on the shop floor. The introduction of similar technologies in companies where qualified shop floor personnel still enjoy a considerable scope for decision making can result in a gradual undermining of shop floor autonomy and will thereby, in the long run at least, jeopardize the utilization of skills.

On the other hand, however, it is also conceivable that, due to the functional deficiency of centralistic control systems, alternative concepts will be employed from the start and that the preconditions in terms of organization and skills for successful operating will be systematically planned and subsequently realized during the implementation process.<sup>1)</sup> Therefore it is of decisive importance which in-plant groups plan and implement technological innovations and what the former's interests and specific aims are. The realization of company structures according to the model of process-related utilization of qualifications is, for example, more likely to occur when the (shop floor) managers directly responsible for the manufacturing process have more influence on the latter than members of central departments for work planning or manufacturing control for example.

(3) Apart from the structures of the technology offers and the specific interests which come into play in the course of the user's implementation process, the quantitative and qualitative availability of personnel is certainly of considerable significance for shaping and designing manufacturing organization and work structures. Forms of process-related qualification utilization are easier to realize or maintain in those companies which already have a workforce with broad and relevant skills at their disposal or where qualification deficits can be made up for at relatively low training expenditures.

---

1) See No. 2.1 of the recommendations concerning education and vocational training further below.

In cases of stagnating or sinking employee numbers it is particularly the qualification structure of the personnel employed within the company which is decisive, due to the fact that an extensive exchange of personnel via the external labour market (dismissal of insufficiently qualified employees on the one hand, recruitment of adequately qualified personnel on the other) would certainly meet with the resistance of the representatives of employee interests and therefore is hardly to be realized.

Those companies who have previously established their organization on centralistic, Tayloristic structures and who have mainly employed the type of the specialized semi-skilled worker in their production departments, will most likely have more difficulties and higher expenditures in carrying through a reorganization process to permit process-related utilization of qualifications and skills than companies whose manufacturing work has traditionally been largely in the hands of qualified, skilled workers. This not only holds true in regard to homogenous qualified group work, but also for structures in the shop floor area based on a certain degree of division of labour. Returning certain planning, control and monitoring functions to the vicinity of manufacturing work when computer-aided integration technology is utilized results in new types of jobs and job requirements which cannot readily be fulfilled by personnel previously employed within more centralistic structures based on a high degree of division of labour.

Although the qualification structure of the given workforce will certainly have an effect on the choice and introduction of new technologies and the resulting reorganization of work processes, this factor can only be regarded as invariable from a short term perspective. Changes can be brought about more or less rapidly by further training and retraining measures carried out by the companies themselves for example, or also - over medium and longer periods of time - by alterations occurring on the company external labour market and within the education and vocational training system.

### 3. The Part Played by Education and Training in the Development of Future Factory Structures

---

Presently the tendencies in industry towards technological-organizational change are meeting with workforce structures with varying degrees of affinity for a process-related utilization of skills and qualifications. While there are certain deviations within the national framework, between different branches, companies with different manufacturing, organizational and personnel utilization structures etc., these deviations are likely to be considerably greater on a European level. Due to their central mediating function in the determining of the quantity and the qualification structure of the workforce available for industrial work the education and training systems, which are strongly conditioned by specific national norms and traditions, are of considerable significance.

As a systematic, comparative analysis of the different European education and vocational training systems is naturally not the intent of this paper, we will restrict ourselves in the following to point out several problem constellations which are important for the question of future factory structures.

(1) An initial point is concerned with the question as to the education and training system's capability of securing adequate manpower reserves in terms of quantity and quality for industrial employment and particularly for work in the area of manufacturing. At least in the long-term a definite affirmative answer to this question can by no means be taken for granted. It has been particularly the expansion of educational opportunities and the opening of schools, universities and colleges for sections of the population previously following other courses of education which has encouraged many young people to remain as long as possible within the education system and to then strive for positions outside of industry, particularly those outside of the actual manufacturing area with all its adverse working conditions such as noise, dirt, shift work etc. This problem can

certainly not be simply reduced to the question of appropriate



training offers and functioning control mechanisms in the area of schools and training, but points most clearly to the conditions of working life and career chances offered by industrial work itself. The chances for recruiting employees for industrial work must, in the long run, be viewed in comparison with the working conditions, earnings and career patterns etc. offered elsewhere.

(2) The question as to the necessary reform of the trades and the contents of vocational training must be regarded in terms of education and training policies. There are many indications that in the course of computer-aided rationalization processes the lines traditionally drawn between existing trades and occupations will become obsolete and that new qualifications and skills will become significant. It is particularly the work forms of process-related utilization of skills and qualifications which seem advantageous to the companies from many points of view and which push strongly towards a dissolution of traditional job classifications and demarcation lines between trades. While technical knowledge and skills related to specific products and manufacturing methods which are necessary for coping with manufacturing processes obviously remain important, on the other hand a know-how concerning EDP, control technology and related technological knowledge necessary for monitoring, controlling and maintaining more complex manufacturing systems is becoming increasingly important. At present no general solution exists to how such qualification requirements are to be grouped and combined to form new jobs and trades. Apart from the very lengthy periods of time required for establishing reforms within the education and vocational training systems, this certainly also has to do with the fact that in many cases the application of modern control and manufacturing technologies has not yet advanced beyond the pioneer stage and therefore company experiments concentrate on the reorganization of the remaining work tasks.

In the Federal Republic of Germany for example a bill concerning the reorganization of the industrial metal working trades was passed at the end of 1984 whereby the number of recognized trades was strongly cut back (from 42 to 6 trades) while the commonly required basic technical knowledge of various

was increased and knowledge of EDP, system control and general process engineering is more strongly integrated (compare Buschhaus, Gärtner et al. 1984).

(3) A similar educational problem exists concerning the combination of knowledge and skills more theoretically oriented and those more concerned with practical aspects. Not all European countries have a tradition of a worker type similar to the German industrial skilled worker who combines theoretical and practical skills as well as a considerable potential for adapting and learning in a specific manner. This type of qualification profile certainly offers favorable conditions for the realization of work structures according to the model of work groups with homogenous skills, specially if there is a wider range of common technical knowledge compared to a more differentiated structure of jobs and trades. However, when theoretical and practical knowledge and skills are taught in different educational and training courses and in different places (such as school and company) then more differentiated forms of work structuring and utilization of qualifications are far more likely to occur.

(4) The form in which higher and advanced technical knowledge is taught at institutions such as technical colleges and universities as well as the training patterns and the subjects emphasized will certainly be significant for the development of future industrial structures. There are several reasons for this:

- o First of all, technicians and engineers have a considerable influence on the developmental process of new control, monitoring and manufacturing technology; the research tradition and forms of logic followed here will surely have an effect - perhaps indirectly in many cases - on certain hardware and software solutions.

- o Secondly the presence or absence of technicians and engineers from different professional fields and with differing orientations within company management will be reflected in the definition of company problems and in the technical solutions

developed; thus certain market impulses (increased demand

made on product variations, for example) will call for different reactions, so that solutions will be sought in the area of production and control technology in one instance or in the field of work organization in another.

- o Finally, the engineers and technicians themselves constitute an important part of the company's total workforce and their varying availability and involvement in certain work situations is not without effect on the development of the structures of in-plant division of labour.

A comparison of the utilization of flexible manufacturing systems in France and in Germany, for example, indicates that certain variations of system-concepts and layout (greater significance of the central computer and software programs in France; stronger concentration on processing machines, handling facilities and transport systems in Germany) definitely have something to do with the difference between both countries with regards to the supply situation and the professional orientation of engineers in the user companies and that these factors also have an effect on division of labour and job design within these manufacturing systems (compare Schultz-Wild 1986b).

In this context the problem is also to mention how to distribute the relevant technological, organizational and managerial knowledge concerning the use of modern computer-aided technologies specially in smaller and medium sized companies and in less industrially developed areas of Europe. In the past the vendors of CIM-components have made some efforts to offer not only hard- and software but also the relevant so called teachware. Also - at least in the FRG - a great number of intermediate, more or less independent institutions for knowledge distribution and retraining in this field have emerged. But there still seems to be a broad field of action, specially on an European level of policy in research, development, education and vocational training.

(5) When the introduction of modern control and manufacturing technologies evolves from the pioneer phase and becomes considerably more widespread and particularly when forms of process-related utilization of skills and qualifications are realized in the process, then the problem of adap

existing workforce in the companies in terms of qualifications must be dealt with. When the initial introduction of new technologies only affects a few employees directly, then qualification problems can be avoided and training expenditures reduced by creaming off the best suited workers for the new jobs. Such a policy of creaming off cannot, however, solve the problems arising when larger sectors are affected by technological-organizational innovations. The capacity and efficiency of in-plant and public training institutions and/or vocational retraining is now decisive. Particularly those companies with a large number of un-skilled and semi-skilled workers will be confronted with the necessity of considerable expenditures and training capacities (in-plant and/or company external) in order to achieve adequate further training suited to adult and already experienced workers. The fact that further training measures can lead to considerable qualificatory achievements when certain preconditions are paid attention to has been proved in numerous cases.<sup>1)</sup>

(6) Finally it must be pointed out that forms of process-related utilization of skills and qualifications within the complex manufacturing systems necessitate new forms of cooperation, particularly when a hierarchical distribution of responsibility is refuted and more open and less rigid forms of task distribution are practised. The capability and willingness to cooperate are specific requirements, which partially contradict the traditional forms of individual learning and individual work performance. As far as this issue is concerned, it does not suffice to merely formulate the demand made on the education and vocational training systems to place a stronger emphasis on collective learning processes, but it must be stated that new forms of cooperation require the support of adequate wage and gratification systems within industrial companies. Particularly when group work is more strongly favored this also means that new career patterns must be developed or other ways and means must

---

1) Compare for example Schultz-Wild, Asendorf et al. 1986; see also the relevant recommendations further below in this volume.

be found of ensuring that manufacturing work will, also in the long run, continue to offer sufficiently attractive chances of earning and reasonable working conditions.

Surely more differentiated observation and analysis would be necessary in order to establish in detail how the problems mentioned here could be solved in the light of the different traditions and conditions in education and employment prevailing in the various European countries so that favorable conditions would be created for the development of future factory structures.

## Literature

- ASENDORF, Inge; NUBER, Christoph: Qualifizierte Produktionsarbeit - Die Renaissance des Facharbeiters in der industriellen Produktion. In: T. Malsch, R. Seltz (eds): Die neuen Produktionskonzepte auf dem Prüfstand, Berlin 1986.
- AWF (Ausschuß für Wirtschaftliche Fertigung e.V.): Integrierter EDV-Einsatz in der Produktion - CIM (Computer Integrated Manufacturing), Begriffe, Definitionen, Funktionszuordnungen. Eschborn 1985.
- BEHR, Marhild von; HIRSCH-KREINSEN, Hartmut: Qualifizierte Produktionsarbeit und CAD/CAM-Integration - erste Befunde und Hypothesen. In: VDI-Z, Bd. 129, Nr. 1, 1987.
- BRÖDNER, Peter: Fabrik 2000 - Alternative Entwicklungspfade in die Zukunft der Fabrik. Berlin 1985.
- BUSCHHAUS, D.; GÄRTNER, D.; GOLDBRÄBE, A.; HOCH, H.-D.; KRISCHOK, D.: Neue Berufsstruktur für die industriellen Metallberufe. In: Berufsbildung in Wissenschaft und Praxis, Heft 6, 1984.
- EVERITT, Peter R.: The Manufacturing Cell "A Plant Within a Plant". SME Technical Paper MS 85 - 901, Dearborn 1985.
- FIX-STERZ, J.; LAY, G.; SCHULTZ-WILD, R.: Flexible Fertigungssysteme und Fertigungszellen - Stand und Entwicklungstendenzen in der Bundesrepublik Deutschland. In: VDI-Z., Bd. 128, Nr. 11, 1986.
- HIRSCH-KREINSEN, Hartmut: Technische Entwicklungslinien und ihre Konsequenzen für die Arbeitsgestaltung. In: H. Hirsch-Kreinsen; R. Schultz-Wild (eds.) 1986, S. 13-48.
- HIRSCH-KREINSEN, Hartmut; SCHULTZ WILD, Rainer (eds.): Rechnerintegrierte Produktion - Zur Entwicklung von Technik und Arbeit in der Metallindustrie. Frankfurt/München 1986a.
- HIRSCH-KREINSEN, Hartmut; SCHULTZ-WILD, Rainer: Implementation Processes of New Technologies - Managerial Objectives and Interests. In: P. Brödner (ed. : Skill Based Automated Manufacturing. IFAC Workshop, Karlsruhe, Federal Republic of Germany, September 3-5, 1986b.
- HUMMEL, R.: Computerintegrierte Fertigung am Beispiel einer Blechfertigung. Beitrag zum internationalen CIM-Kongreß zur System '86. In: VDI-Gesellschaft Produktionstechnik (ADB) (Hrsg.): Rechnerintegrierte Konstruktion und Produktion 1986. Düsseldorf 1986, S. 127-151.
- PIORE, Michael J.; SABEL, Charles F.: The Second Industrial Divide. Possibilities for Prosperity. New York 1984.

- SCHULTZ-WILD, Rainer: Entwicklungsbedingungen und Arbeitsstrukturen in der mechanischen Fertigung. In: H. Hirsch-Kreinsen; R. Schultz-Wild (eds.) 1986a, S. 143-173.
- SCHULTZ-WILD, Rainer: New Production Technologies and their Implications for Manpower and Training Policies. EC-Symposium "New Production Systems", 2nd - 4th July, Torino 1986b.
- SCHULTZ-WILD, R.; ASENDORF, I.; BEHR, M.v.; KÖHLER, Ch.; LUTZ, B.; NUBER, Ch.. Flexible Fertigung und Industriearbeit - Die Einführung eines flexiblen Fertigungssystems in einem Maschinenbaubetrieb. Frankfurt/München 1986.
- WARNECKE, Hans Jürgen: Von Taylor zur Fertigungstechnik von morgen. In: wt (Zeitschrift für industrielle Fertigung), 75. Jg., 1985, S. 669-674.







INTERRELATIONSHIPS BETWEEN FIRMS IN MANUFACTURING

Contribution to the EC-FAST research program on  
'New Production Systems'

Frits Prakke

Centre for Technology and Policy Studies - TNO  
State University of Limburg  
Apeldoorn, January 1987

1.

INTRODUCTION

There is ample evidence that the availability of computer technology combined with fierce global competition is presently revolutionizing manufacturing firms in the European Community.

Several chapters in this report bear witness to the growing body of research on this topic. Man-machine relations, the nature of work, the production-organization and the educational system, all are rapidly being transformed. As the technology, economics and organizational rules of manufacturing are changing, it must equally be clear that the interrelationships between firms must also change. There has been quite some speculation on this issue in industrial circles, but very little adequate empirical evidence on how industrial structure is changing due to the introduction of new production systems. This analysis will therefore be necessarily lacking in results of empirical research. Nevertheless it seems worthwhile to structure the issues that have been brought forward. We will focus our attention in section 2 on the changes presently taking place in subcontracting relationships. Changes in the area of regional clustering of firms and technology oriented collaborative networks between firms in general will be briefly looked at separately in section 3.

## 2. SUBCONTRACTING RELATIONSHIPS

The landscape of subcontracting is more complex than often assumed. When analyzing changes in subcontracting relationships it is useful to keep the following typology in mind of roles played by firms in that landscape.

1. Original Equipment Manufacturers (OEM's). These are the firms that develop, design, produce and market products under their own brandname. Their in-house manufacturing may in some cases be restricted to only the vital or core processes, on which the exclusive nature of the product on the market is based. Final assembly is almost always one of these. Simpler functions and special subsystems and components can be subcontracted to others.
2. System Suppliers are firms that supply complex systems to be integrated in the final product of the OEM's, based on their own specialized technical knowledge. Classic examples are jet engines, brakes and transmissions for automobiles, and catering to airlines. Note that service sector firms can increasingly be seen as System Suppliers.
3. Component Manufacturers supply parts to OEM's or to Systems Suppliers which can be technologically complex, but which are not to any great extent adapted to the special demands of different customers. Examples are automobile tires, lamps and standard microprocessors.
4. Material Suppliers produce relatively simple, multi-user mass goods such as wire, paint and steel, generally at commodity prices. They are dependent on economies of scale. Very little individual service or adaptation of the product is offered to the customer. Materials Suppliers and Component Manufacturers who want to increase their margins and exploit technical know-how by offering technical service and individual adaptations in a sense become Systems Suppliers. We see this strategy, for example, among chemical firms that will go to great lengths to support technologically their customers in the plastic products industry.
5. Jobbers form the category of firms that produce parts or, more generally, perform manufacturing functions, based on speci-

fications drawn up by their customers. They are specialized in particular standardized manufacturing processes, for example cutting, galvanizing, machining.

Figure 1 gives a simplified view of the subcontracting interrelationships between firms. The core-periphery hierarchy reflects different degrees of technological independence with respect to product innovation, which can also be referred to as design leadership. Jobbers of course may be highly technically advanced and even have exclusive knowledge of the production process. No value-judgment is intended by the design leadership hierarchy.

The percentages in figure 1 at 0 to 360 degrees of the circle allow the indication of value added for a particular machine or piece of equipment by each of the five types of firms. A total of 360° in the circles adds up to 100% of value added. Changes in these percentages are a measure of change in industrial structure.

There is a very pervasive trend in which industrial firms are turning away from vertical integration of their activities. This is a logical consequence of the shift since the post World War II reconstruction period to a period of full supply and liberal international trade. Power has shifted from producers to buyers. Make or buy decisions in firms are increasingly resulting in the latter option. Firms are retreating to their core business in which they have some exclusivity. The Japanese economy is a leading example in this. This trend results in an increase in the volume of subcontractors relative to all production in industry. A recent Dutch study found that fully 80% of 500 surveyed firms reported that their subcontracting had increased sharply in the past few years.

At the same firms demand more from their subcontractors in terms of quality and flexibility. Subcontractors that lag behind in introducing 'new production systems' risk losing their market. A complicating factor is that customer firms (e.g. OEM's) under pressure of restructuring often stress short-term relationships with subcontractors, especially jobbers, based on price and

Figure 1: Subcontracting typology.

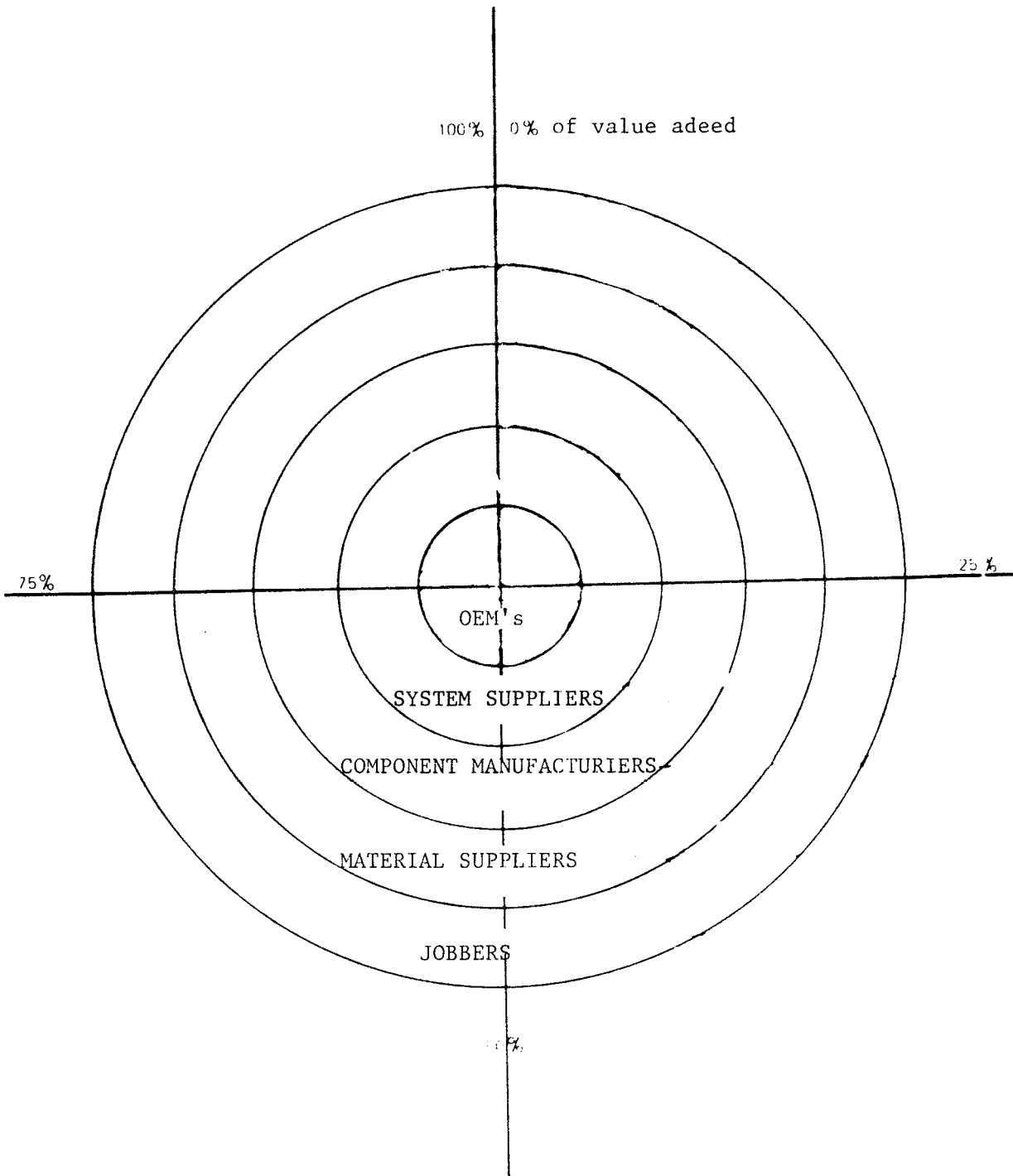

time pressure. This can be a barrier to long term improvement in the subcontractor's manufacturing technology. A negative vicious circle of dependency and low investment in manufacturing capability can be the result. The quality of labor is then also likely to suffer. More competitive OEM's are moving in a different direction. They are moving toward contracts based on periods of time rather than on quantities of products. Such strategies allow the subcontractor to improve his manufacturing technology, including human resource management. The tendency to reduce the number of subcontractors means a shake-out, which is presently taking place. For example, Océ-van der Grinten has recently reduced its number of subcontractors from 5.000 to 350.

When design capability enters into the subcontracting relationship customers demand technical and financial risk taking by their subcontractor 'partners'. It is logical that, as vertical integration in industry is decreased, more sensitive relations are required between subcontracting partners. This is also referred to as co-makership. Again, we see a more intensive management of relations with fewer sub-contractors. Large firms in Europe are talking of reducing the total number of subcontractors, at different levels of the hierarchy in Figure 1, by 30 to 40 percent. The result in terms of industrial structure could be fewer but larger subcontracting firms.

Exporting products to global markets, especially the U.S., exposes a firm to demands from liability insurance companies which force quality accounting systems to be set up. Every manufacturing error must be traceable. Therefore subcontractors must adapt to these systems, if they want to survive.

### 2.3. Technological trends

The 'new production systems' result by way of computer integrated manufacturing (CIM) in a high degree of intergration of productive activities within the firm. The new factory can be characterized as follows:

- production in respose to demand; machines wait for products rather than the other way around; just-in-time production
- product oriented rather than functional organisation of the production
- minimum changeover costs
- maximum flexibility and quick turnaround capability
- minimum downtime for unanticipated maintenance, but continuous maintenance attention.
- maximum product-family range
- the ability to handle increasingly complex product design and technology
- maximum respronsiveness to surges in demand.

Such internal integration and flexibilisation of production leads, at least hypothetically, but also based on signals from industry, to the following technical trends. These are generally reinforced by some of the economic trends indicated above. It should be kept in mind that more empirical research is needed to assess the precise extent and speed of these technical trends.

Increased use of flexible automation is leading toward pulling back of some smaller series from subcontractors. This is due not only to the flexibility of the new systems but also due to the jump in capacity they often represent.

New subcontracting relationships are increasingly requiring much closer technical contacts between personnel of the partners. Cultural barriers can become a hindrance in Europe to fully exploiting the possibilities of subcontracting and true co-makership. There are too few technicians in Europe with the experience and attitude to bridge such barriers. Early experiences in the ESPRIT program seem to attest to this.



Adopting the software standards of the customer is increasingly a requirement for subcontracting, also for previously very independent jobbers. The Manufacturing Automation Protocol (MAP) is quickly being diffused at present, perhaps whilly nilly. For example, Austin-Rover subcontractors are reported to be quite unhappy about being required to adopt the Computer-Vision CAD system. New technology to improve the compatibility of software, while perhaps not in the interest of any one producer, would act to redress the presently threatening software dependencies.

J.I.T. production management and quality assurance are becoming more and more important at a fast pace. This is putting great pressure on many firms to improve their technological competence. The following levels of manufacturing technology can be distinguished.

1. leading edge technology
2. state-of-the-art technology
3. common practice technology
4. backward technology

As manufacturing technology is developing rapidly on the critical dimensions of J.I.T. and quality assurance, the great majority of subcontracting firms at levels three and four are in acute danger of being left behind. Especially technologically isolated firms are in danger of not surviving the coming shake-out. This can do lasting damage to the European industrial structure and to particular sectors and regions.

### 3. OTHER INTERRELATIONSHIPS

#### 3.1. REGIONAL EFFECTS

The economic and technical trends presented above may also have effects on the regional clustering of firms. Trends in the nature of the process of the development of new products as well as in the nature of manufacturing are leading in the direction of closer ties between firms. In some cases this has already resulted in the re-location of sub-contracting and services to a particular region. Production is called back from distant countries and peripheral regions that only offer low costs of labour or government subsidies. Just-in-time manufacturing favours shorter distances to subcontractors and therefore geographical concentration. Co-makership and joint development of products favours firms from the same culture and even from the same region. The increasing dependency of industrial firms on service firms also encourages the trend of geographical concentration. It can therefore be stated that regional development must increasingly be based on specialisation. This specialisation will not so much be based on traditional comparative advantages in terms of the price of the production factors, but based on historically and culturally inbedded advantages in terms of human resources. This trend can be seen as a threat to the aspirations of non-industrial peripheral regions of Europe wishing to base their economic development on the import of high technology branch plants.

#### 3.2. TECHNOLOGICAL CALLOBORATION AND NETWORKS

The new trends in industry mean that large numbers of firms are in danger of becoming technologically isolated at a time of rapid technological change, for many this could be fatal. The succesful firms of the future will need to be part of technological networks, in which information exchange and learning about the latest techniques takes place. Such networks can be based on single very large OEM's. Japanese automobile manufacturers in the U.K. have been seen actualy creating such networks, very

tightly managed, out of a previously incoherent and "backward technology" group of local subcontractors. But networks can also be based on programmes of pre-competitive research, on university institutes or on branch institutes, for example a brewery institute, often with a strong regional orientation. Such networks are created and can perform a very useful function in a situation of rapidly developing technologies and isolated producers. The stormy introduction of new systems of production certainly seems to represent such a situation and should therefore be the object of interfirm network building by local, regional, national or supra-national initiatives.





THE INTEGRATION OF PRODUCTION PROCESSES AT FIRM LEVEL.

by

BILL HAYWOOD & JOHN BESSANT.

Innovation Research Group.  
Brighton Polytechnic. U.K

CEC-Fast Working Group on  
"New Production Systems"

January 1987.

#### 4.1 THE INTEGRATION OF PRODUCTION PROCESSES AT FIRM LEVEL.

##### Abstract.

Considerable interest is currently being expressed in the concept of Computer Integrated Manufacturing (CIM). In its broadest sense, CIM refers to the integration of all aspects of manufacturing within a networked computer system, offering the possibility of controlling and optimising the performance of a factory as if it were a single complex machine (1).

Some interesting conclusions regarding the diffusion and implementation of Flexible Manufacturing Systems (FMS) as an example of the early stages of CIM, are beginning to appear from studies being carried out at Brighton Polytechnic in the United Kingdom (2). In more than seventy interviews with manufacturing engineering companies, suppliers of software and hardware, and other trade, research, and government bodies - supported by an exhaustive literature survey - two major characteristics emerge. First, the need for all aspects of manufacturing to be integrated, and second, the need to consider not just FMS, but more importantly, flexibility in manufacturing and in its organisational and methodological interfaces.

The main aim of the research was to see how far the diffusion of automated manufacturing technologies had progressed in the U.K.

and FMS (and Flexible Manufacturing Cells) were seen as the first major step towards full Computer Integrated Manufacturing (CIM). The first part of this paper, which is concerned mainly with the metal removal industries, (FMS, is of course, applicable to a wide range of other industries such as furniture, rubber and plastics, foundries, etc,) and gives a brief outline of the research and its findings, and the latter sections deal with a number of policy issues.

Although the research was mostly concerned with the technical aspects of FMS, it became increasingly clear to us that in many instances a re-evaluation of the organisation of production and the methods employed was at least as important for the companies that we interviewed.

#### 4.1.1 Introduction: The Trend to Computer Integrated Manufacturing.

As in all other countries, the introduction of computers in the UK has tended to be rather fragmented in the past. There was little of it, it was expensive, physically energy and space consuming, few people who knew how to run it effectively, and it was devoted to specific functions, such as, salaries or tool stocks. All these factors are now rapidly changing and the integration of all of aspects of manufacturing is growing from the receipt of orders through design, planning, production, assembly, despatch, etc. This can be visualised by reference to



a model offered by Kaplinsky (3).

He suggests that manufacturing can be divided into three distinct spheres of activity - design, manufacturing, and coordination, (Figure One). Historically these activities tended to be discrete and the process has been one of technological and organisational change leading first to integration within spheres and later to integration between spheres. A good example of this process can be seen in the case of machine tools; in the early factories, each operation was carried out by a single special purpose machine. Gradually there was an integration, first of the functions which a single machine tool could perform and later, with the advent of numerical control, of the skilled operator input. Later still came the principles of direct numerical control whereby a set of multi-function machine tools can be controlled within a production cell by a master computer.

Current interest is focussed on FMS which permit handling and transport to be automated (via robots, automatic conveyors, automated guided vehicles, etc.), production scheduling and overall operations control all under computer control. This is a clear example of integration between spheres, bringing together the coordination and production activities; other examples include computer aided design and manufacturing (CAD/CAM), and CAD links into computer-based inventory control and purchasing systems. Facilitated by the fact that electronics provides the common language necessary for inter-sphere communicationsuch

convergence inevitably leads to the idea of fully computer-integrated manufacturing in which all spheres of manufacturing are linked.

Figure One.

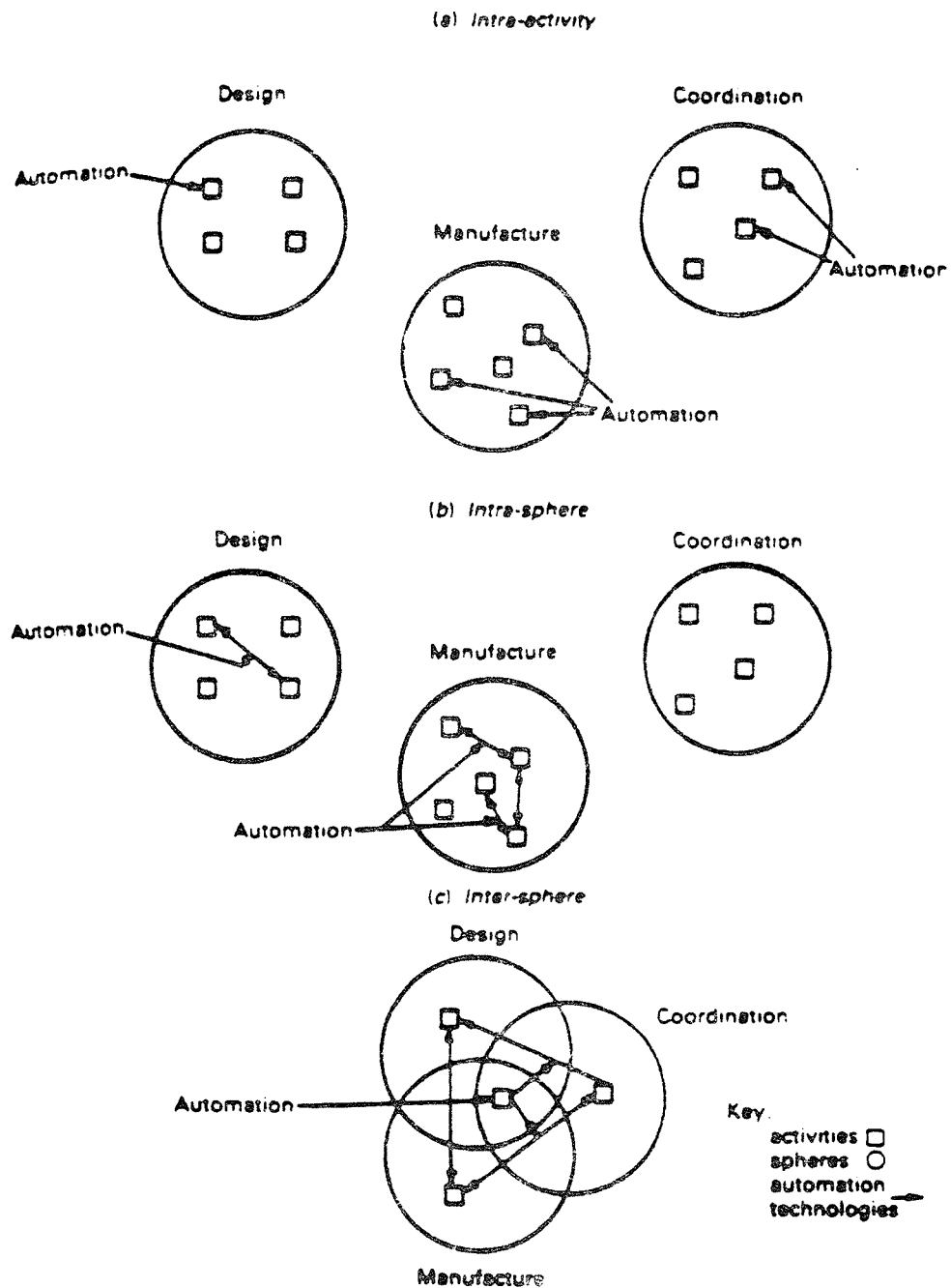

However, integration does not stop there, for increasingly companies are looking at links, both with their customers and their suppliers. In both cases they are examining their relations at the technical level where CAD-CAM can be so important, and the links that exist organisationally with other companies. In the latter case this is what Williamson (4) has called "obligational contracting", and Solow (5) has described in a labour relations context as "more like a marriage than a one-night stand". Lanning (6) has observed that in the U.K car industry, the traditional relationship between the buyer and the supplier has involved: closed competition; one-sided design effort; restricted information flow; and delivery patterns primarily geared to the buyer. He believes that the purchasing function will lose its overall control or, that a new "superbuyer" with all aspects of contact, and liaising between other specialists might emerge. He might perhaps be called a "procurement engineer". This is the more common form of contracting in Japan (see Dore 1983 (7)). In these new terms therefore, an expanded version of the Kaplinsky model is needed and this is provided in Figure (Two), (8).

Figure Two.

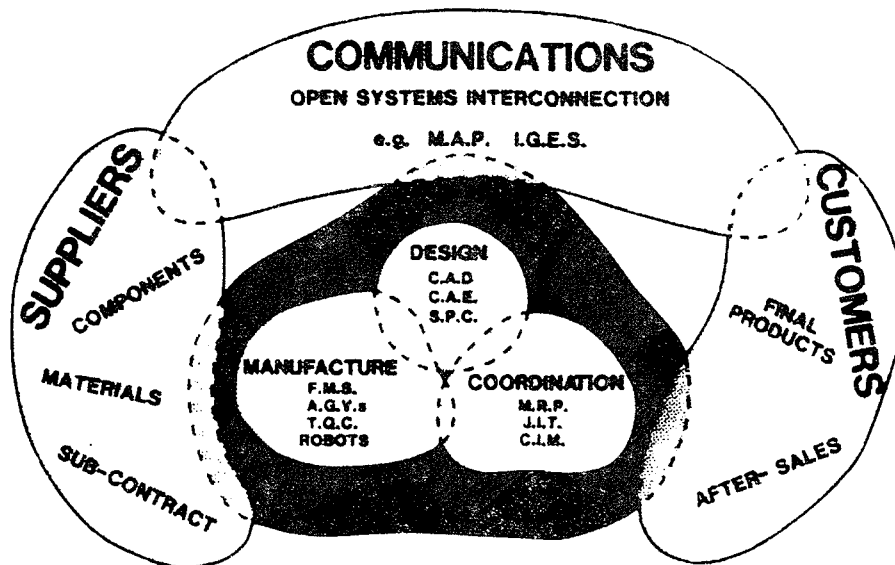
**KEY**

- M.A.P.** Manufacturing Automation Protocol
- I.G.E.S.** Initial Graphics Exchange Specification
- C.A.D.** Computer Aided Design
- C.A.E.** Computer Aided Engineering
- S.P.C.** Statistical Process Control
- F.M.S.** Flexible Manufacturing Systems
- A.G.V.s** Automatic Guided Vehicles
- T.Q.C.** Total Quality Control
- M.R.P.** Material Requirements Planning
- J.I.T.** Just-In-Time
- C.I.M.** Computer Integrated Manufacturing

In the Kaplinsky model we are offered a picture of integration within the firm. Here we anticipate growing links between firms as well. If this is the case then there will also be a growing need to establish an overall communications system which would allow common standards within Open Systems Interconnection

networks eg, the General Motors initiative - Manufacturing Automated Protocol (MAP) -, or the Initial Graphics Exchange Specification IGES).

#### 4.1.2 The Benefits of Flexible Manufacturing Systems.

Flexible manufacturing systems offer a number of solutions to both the internal and external competitive pressures being increasingly felt by companies. Internally, of particular importance are the wide range range of problems associated with batch manufacture. Such problems include:

- Long production lead times
- High inventory levels of raw materials, work in progress and finished goods
- Low machine utilisation due to long set-up times and product changes
- Low machine utilisation downstream of bottlenecks
- Queuing problems at bottleneck operations
- Problems in introducing new products
- Poor delivery performance
- Poor quality control
- High scrap levels
- Poor production control, leading to high overheads - for example, in progress chasing, etc.,.

One indication of the extent to which such manufacturing

conditions represent a threat to efficiency is the fact that in many firms a product will spend up to 95% of its time in the factory moving around or queuing, with value adding operations often accounting for only 2% or so of the time spent in the factory.

The potential benefits of FMS style technologies are considerable. In our study we discovered quite dramatic changes in a whole series of important manufacturing criteria, such as:

Lead Times, reduced on average by -74%

Work in Progress, reduced on average by -68%

Stock Turnover, increased on average by 350%

Machine Utilisation, increased on average by +63%

(Up from say 50% with CNC to more than 80% with FMS)

Given that an estimated £23B is currently held in materials and components in U.K manufacturing engineering the benefits for the average company are obviously very considerable. Data on FMS is still fairly limited since such systems are in the early stages of diffusion and most have only recently been installed. However, one of the key points which is emerging from this early experience is a need for significant organisational change to obtain the full benefits from new technology. It appears that this factor is likely to be an important determinant of how well firms are able to appropriate the benefits of CIM; at present there is considerable lag between the adoption of technology adoption and that of organisational adaptation. As Perez (9) suggests there is " a serious mismatch between the

socio-institutional sphere and the new dynamics in the techno-economic sphere".

These moves towards highly-integrated technology for the "factory of the future" will require a major rethink about production organisation and management. Traditional "best practice" in production engineering will have to be combined with new management techniques and organisational forms - including a re-examination of the relationships between the workforce and the technology, and the political and social objectives of management. Following Dosi (10), such a pattern might represent a new production paradigm. As Perez suggests:

"When the full constellation of a new techno-economic paradigm tends to take over the bulk of production within a society, it will not yield its full growth potential until the socio-institutional framework is transformed to adapt to its requirements".

Externally firms are being forced to respond much more closely to customer demand. This means shorter lead times on delivery, better delivery performance, high and consistent quality, and particularly, the ability to meet an increasingly customised product specification. With many markets becoming much more fashion-like with shortening product lifecycles, this puts severe pressure on firms to develop more flexibility and responsiveness characteristics which have been termed "manufacturing agility". It is significant to note that these pressures for agility are confronting even firms in the mass and flow line sectors, where traditional patterns of scale economy are being replaced by growing demand for smaller quantities of

more customer specific production and variety - what have been termed "economies of scope" (11)

It is in response to these trends that the various elements of CIM have begun to evolve and converge, and FMSs are one of the major innovations in this area.

#### 4.1.3 CIM or C/HIM?

Much of the current discussion of integration has centred on Computer Integrated Manufacturing (CIM). However, our research convinces us of the need to think more in terms of Computer/Human Integrated Manufacturing. Although many benefits can be obtained and give support to the claims for the potential of advanced manufacturing technologies, getting the best performance from them involved considerably more than simply taking the decision to adopt the technology. This confirms the findings of other workers (such as, Senker (12), Fleck (13), and Voss (14) ), who point out that getting up to best practice performance, or achieving the kind of benefits which suppliers offer, can take months or even years. In particular, as Voss suggests, what is needed in successful implementation is simultaneous technological and organisational change.

In terms of skill, theories based on the division of labour and economies of scale seem to be becoming supplanted by multi skilling and economies of scope. These are much more relevant to



production requirements where in batch manufacturing, for example, around 70% of output in metal manufacturing lies in batches of less than fifty. FMSs and Cells, which answer many of these production problems, call for multiplicity of skills (eg, setting, programming, simple maintenance, diagnostic skills, etc,) rather than employing a wide range of specifically skilled people. This can be seen in a recent study of Messerschmidt-Bolkow-Blum (M.M.B) (one of the largest F.M.S installations) which needed exceptionally high levels of highly skilled maintenance personnel in order to keep it running effectively (15).

Attempts to develop a fully automatic factory with no human intervention whatsoever are unlikely to meet with much success because of the enormous risks and costs associated with developing suitable software to control such systems. As Brodner states:

"Most managers and production planners follow a strategy to replace human work still further by enforced use of computers on the shop floor and in the technical office in an integrated manner. Since this strategy is in danger of creating new problems, the growing minority seek to avoid them by reorganising production and rearranging the division of functions between man and machine in a way that makes use of the worker's skills instead of reducing them to operating servants" (16).

Research by Wall, et al, (17), for example, has begun to demonstrate the importance of rethinking operator roles within advanced manufacturing systems. In their work on small flexible cells they found that in addition to a deskilling machine minding role, there was a need for a highly skilled "operator

midwife" role which involved intervening when problems with the largely automated control system emerged. It is important to note that the objective in such systems moves from one in which labour is seen as a necessary evil and a cost item to be reduced or eliminated wherever possible, to one in which it is seen as being an important aid to keeping the utilisation of the system high - and thus to recovering its high capital costs.

There has also been some debate regarding the erosion of distinctions between "direct" and "indirect" labour, with increasing dependence on the traditionally defined indirect workers to keep such systems running. Perhaps of greatest importance is in the fields of maintenance where there is a need to examine the pattern of skill availability and its development. Technological integration is bringing a number of new demands in the skills required of an individual, particularly in the areas of more flexibility and breadth. Senker (18), and Senker & Arnold (19), identifies this need in a number of applications and industries; pointing out that the major influence which provision of, or lack of suitable skills and training can have on the speed with which firms are able to achieve best practice performance with CAD systems. Hancke (20) has also observed in his study of M.B.B in Augsburg, the extent to which maintenance skills, especially the newer ones such as systems analysis and diagnostics, contribute to the utilisation of advanced manufacturing systems - and hence, to the rapid repayment of their initial costs.

The "indirect" element is harder to quantify, but most firms appear to have used increased levels. For example, in Japan, Driscoll (21) found that, while only six people were employed directly on running the now well known Yamazaki installation, ten times more were employed in support of it (eg, for programming, for swarf removal or parts movement, button pushers, etc.). While direct labour saving might be quite high, overall levels of employment were much less dramatically affected. In fact, more recently, Konosuke Matsushita when talking about competition with the industrialised West said:

"We are going to win and they are going to lose. We are beyond the Taylor model....the survival of firms....depends on the day-to-day mobilisation of every ounce of intelligence. For us the core of management is precisely this art of mobilising and pulling together the intellectual resources of all employees in the service of the firm....The intelligence of a handful of technocrats is not enough to take up (the technological and economic challenges) with a real chance of success". (22).

However, as far as the U.K is concerned it may still be appropriate to employ these distinctions of direct and indirect labour. We have found that while there may be less "direct" skilled labour required as a result of the introduction of FMS, manpower demand in the U.K has tended to be for a higher quality of labour.

Our study shows job-loss amongst direct labour as a general trend, but that job-growth and quality of life improvements have probably occurred in the three other quadrants shown below. In

the past, most emphasis has been put on this direct labour impact - with good reason given the social implications. However we define "quality of life" (eg, less division of labour, health and safety improvements, enlarged job opportunities or skills, etc), it appears that at this stage of the diffusion process, the impact in the U.K has tended to be positive. We should keep in mind though, that quality of life changes within a group might well vary considerably. It is also likely that the diffusion process will dramatically change these early findings and that as such systems proliferate, there will greater job loss if we fail to re-define the relationships between the worker and the computer.

		LABOUR	
		Direct	Indirect
Employment		-	+
Quality of Life		+	+

#### 4.1.4 Organisational Factors.

Much of the preceding discussion has been in respect of the technological problems and opportunities posed, but the importance of methodological routes to improved efficiency were also stressed. When accounting for overall improvements in efficiency, estimates of the importance of organisational change varied between 40% and 70% of the total improvement. Clearly around half of the improvement tended to come from these types of change. One company which had not introduced FMS/FMC had reduced the level of stocks held by 60% and increased output by 30% just by adopting "good management and methodological practices". This together with investment in standalone Computer Numerically Controlled machine tools led to a trebling of turnover, from 20m to 60m, in the period 1981-4 when most U.K engineering companies were in deep recession. During the period employment was declining in our sample companies by an average by over 30%; yet employment grew in this non-FMS company by some 14%. In other words what was important here was not so much the technology but the adoption of good management and production practices.

The move to FMS and other integrated automation technologies also poses questions about the traditional pattern of functional specialisation. For example, there is the need for the design and production departments to work together to develop products which are suitable for manufacture on an FMS.

Such a "design for manufacture" philosophy is of particular significance in the flexible assembly automation field where small modifications to the design of an item can eliminate the need for complex manipulation or operations within an automated system. In one case, redesign of the product led to a reduction in the number of operations (handling and machining) from 47 to 15 with significant implications for cost and lead time savings. As one manager put it "FMS is going to drive the shop - but it's also going to drive the people who design the product, and production engineering."

The essence of such functional integration is not to eliminate specialist skills but to bring them to bear in a co-ordinated fashion on the problems of designing, producing and selling products - creating a single system view of the process rather than one with many parochial boundaries and little interchange across them. A good example of this can be found in the area of financial appraisal of FMS. Given the high costs of such systems - often running into millions of pounds - conventional accounting methods are often inappropriate since they would reject projects which were unable to show a payback of within two years or so.

FMS is not, however, only a production technology but also a strategic one and the question of whether or not the firm has such flexibility in the future might determine whether and what share it has of future markets. In many of the cases we examined

firms commented that the actual justification for their projects was little more than "an act of faith" - confirming the view that qualitative judgements were at least as important as quantitative appraisal techniques. Thus the question of whether or not to invest needs to be a mixture of quantitative techniques and qualitative judgements expressed by those with different perspectives, such as, marketing, production engineering and corporate planning, in addition to the cost accountants.

In the same way as integrating technologies require closer functional integration, so they imply shorter hierarchies and greater vertical integration in organisational structure. In order to exploit the full benefits of a rapidly responsive and flexible system it is necessary to create a managerial decision making structure which is closely involved with the shop-floor and which has a high degree of delegated autonomy. As yet our experiences of the U.K sector displays almost twice the depth of managerial hierarchies as that found in Sweden, and a lower likelihood of shop-floor autonomy developing in comparison with similar enterprises in Sweden.

At the level of the shop-floor, considerable changes are implied for the pattern of work organisation. With greater reliance on a small group of workers and managers comes the need to look for models of production organisation which have less to do with task fragmentation, division of labour and control by external

regulatory systems of sanctions and rewards and to evolve alternatives based on small autonomous working groups, with high flexibility and internal control. There appears to be a growing awareness of the inappropriateness of Tayloristic approaches which are based on a fundamental dis-integration of work for activities surrounding a fundamentally integrating set of technologies (23).

The rethink required encompasses both the hardware and the software elements of production, right through to the organisationally efficient management of production. Perhaps therefore, we should consider the following figure. This offers, in fairly simplistic terms two options for approaching some concept of the "factory of the future".



Figure Three.

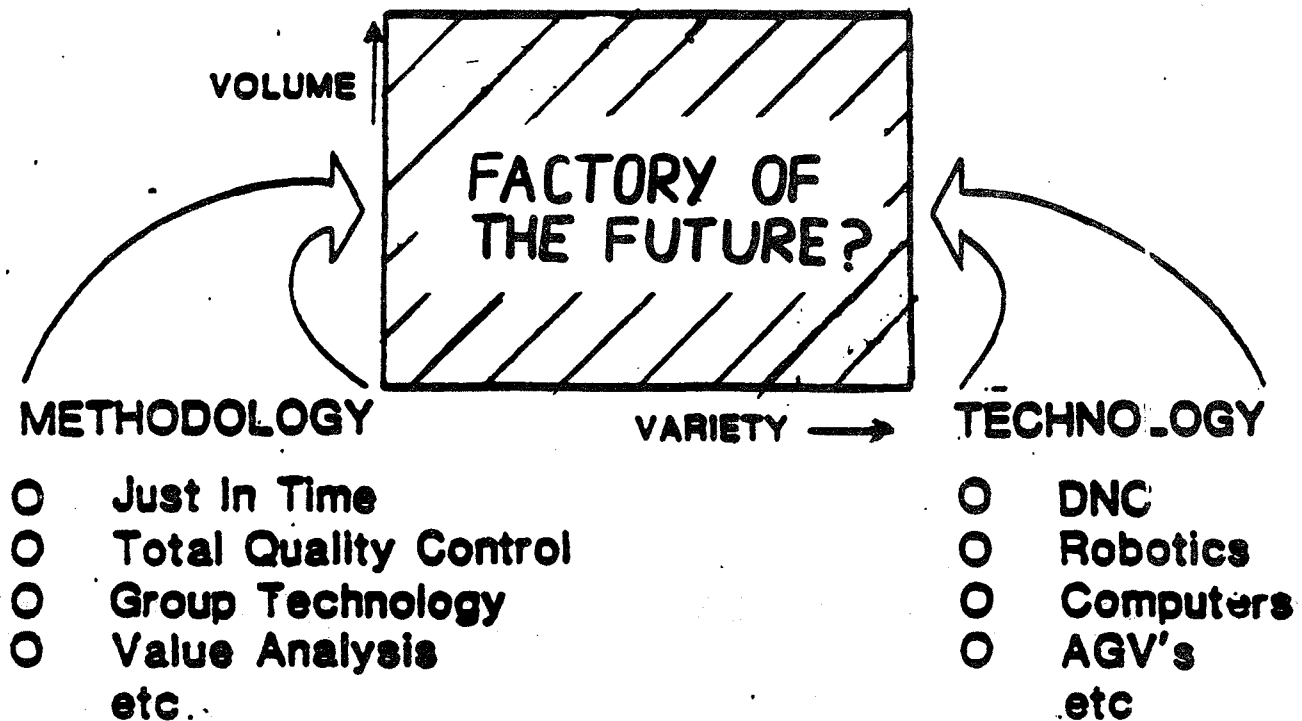

It is becoming increasingly clear that factors such as just-in-time production, total quality control, supplier and customer relationships, etc, are all extremely important in improving efficiency, and that it is not merely the technology that we should consider. Significantly, it is precisely in these areas of organisational and methodological techniques that the

Japanese are strongest, and which are somewhat belatedly attracting the attention of the West. There has been growing interest in these areas in Australia (24), America (25), and the UK (26). No doubt there are many similar experiences that could be highlighted from other countries.

Such aspects of organisational change comes with the adoption of different approaches to the layout and methods of production. Here the influence of Japanese manufacturing techniques can be clearly seen, with emphasis on simplification and planning to achieve smooth flow through manufacturing; making batch processing resemble flow production as closely as possible. The precise configuration of layout and the range of techniques adopted vary. However, in many of the firms we spoke to technological change involving FMS was taking place in parallel with programmes for quality improvement, changing supplier and purchasing policies and moving towards implementing a just-in-time philosophy, both in purchasing and within the production process as a whole.

Many people have talked of the cultural reasons why such "Japanese" style methodological developments are inappropriate for Western countries. However, it would be difficult to think of many "Japanese" production methods which do not have their roots in Western ideas, taken and developed by the Japanese in the 1950s, 60s and 70s. Theorists such as Sloan, and particularly Deming and Juran, have been extra-ordinarily

important to the Japanese, and as Schonberger (27) has pointed out.

"The Japanese have had little trouble learning our techniques, and we will have little trouble learning theirs."

#### 4.1.5 The Policy Implications of Production Process Integration.

In very broad terms it can be argued that although there exist fundamental differences in the nature of manufacturing processes, the demands placed upon enterprises in the manufacturing sector are becoming increasingly similar. Although high volume flow process production (eg, petrochemicals or food processing) involves very different basic processes to batch engineering work, both sectors are now facing pressures from their environment such as:

- Increasing competition, especially on a world-wide basis, with emphasis not only on price factors but also on non-price variables like design, delivery times and quality of product.
- Increasing demands for smaller batches tailored to suit customer needs; even in petrochemicals, flexibility in meeting a wider spread of needs is a high priority.
- Increasing demands for high quality products.
- Increasing demand for better customer service, delivery performance, after-sales support, etc.,.
- Increasing demand for new products on a decreasing life cycle basis.

- Increasing demand for improved linkages with suppliers to facilitate Just-in-Time deliveries, reduced component costs and improved quality of parts.

A direct consequence of this is that firms are being forced to examine their internal environment closely to try and reduce costs. Labour costs are, usually mistakenly, given the highest priority (28), followed by materials, energy, and other factor inputs. In addition firms were also trying to improve quality, reduce lead times, reduce the overall uncertainty in the production process, and so on.

Thus it is, within an admittedly crude frame, possible to consider all factories as "black box" systems - such as shown in Figure Four - which are under considerable pressure to adapt and innovate in order to survive.

Figure Four.

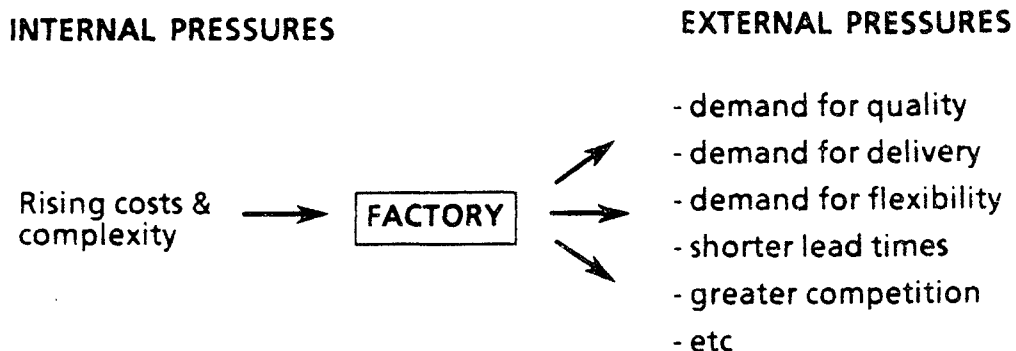

The tools with which firms choose to tackle this problem can be drawn from a large toolbox. Most commonly used are the new, largely computer based technologies largely computer based with which we have become familiar. See Figure Five.

Figure Five

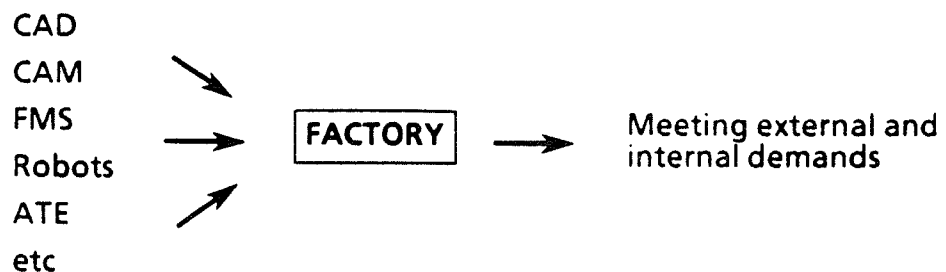

The trends associated with these are essentially integrative at the purely technical level, bringing together physical and control functions into systems and complex machines. In the longer term these are also converging towards what has been termed Computer Integrated Manufacturing (CIM) and which represents a full exploitation of the possibilities opened up by convergence of physical and control functions enabled by information technology. Further, this process does not stop at the boundary of the firm but moves on outwards, integrating along both the supply and distribution chains - as we noted

earlier and displayed in Figure Two.

The point about this is that it is the product of extrapolating one kind of integration at the technical/physical/control function level. Whilst it is easy to make projections of this kind, there is growing evidence that achieving such integration in practice is much more difficult. First there are technical problems at this level, such as the urgent need for suitable standards and protocols to establish the rules for systems interconnection. Second there is growing evidence that even when the technical systems can be integrated, the full benefits which might be expected from such systems do not materialise because of a lack of integration at other levels in the organisation. This experience varies across the industrial spectrum and with firm size.

This suggests that other tools must also be used to support, or in some cases to substitute for, the new technologies. Probably the most significant group are those new methods of production organisation and management which have been exploited by Japanese industry (29). Examples here include Total Quality Control and Just-in-Time scheduling and inventory management, which have strong Japanese roots, and group technology and value analysis which have been tried in a much wider context. The point about all these is that they represent proven production engineering practices which can contribute to solving the problems outlined at the beginning of this section. These can be

achieved at relatively low cost and involving a much lower level of risk for the organisation (30). Figure Three can then be expanded by adding structural considerations. (see Figure Six). It also affords the opportunity of examining the role that the workforce can play in interacting with new technologies. Recent experience suggests in very many cases of pre-installation justification for, and post-installation experiences of F.M.Ss, that firms who had wished to eliminate labour from the production process found the use of skilled workers a profound contributory factor in its efficient use.

Figure Six.

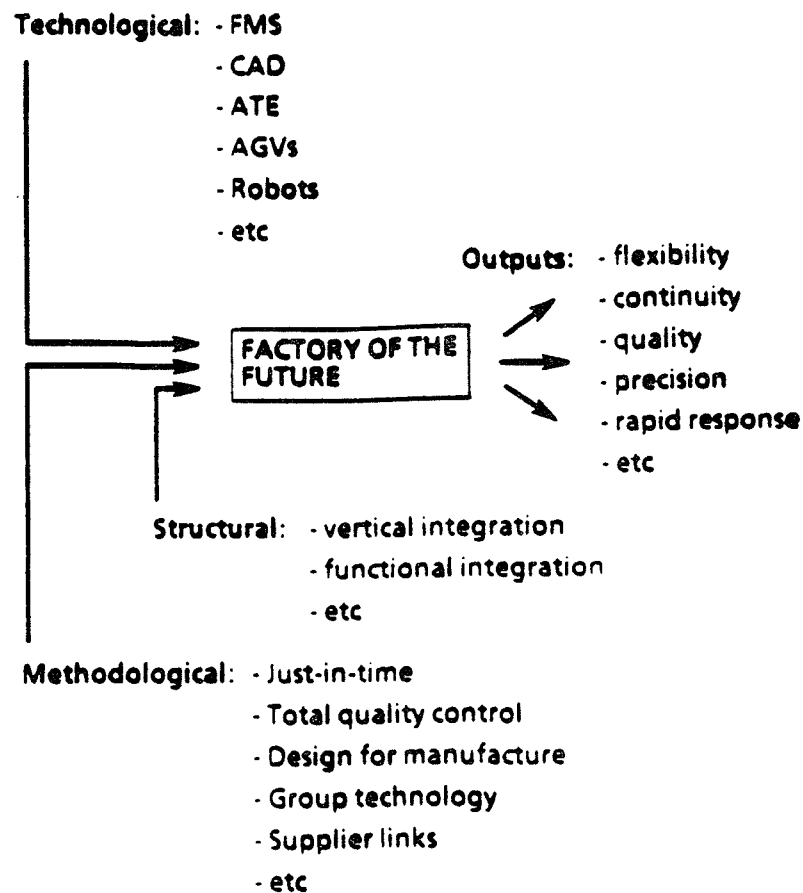

Evidence suggests that implementing either changes in methods or technology in organisations requires some adaptation on the part of the organisation if the benefits expected are to be realised. The importance of this adaptation can be gauged from a variety of reports which suggest that 50% (31), 60% (32), or even 90% (33) of the benefits of technologies like FMS come before the technology itself is implemented - in other words from the organisational changes which it forces the firm to make. The nature of these changes is beginning to be documented, though its detailed mapping remains an important research task for the future. They include:

- changes in organisation structures, especially functional integration, eg, closer coordination of the activities of the research, marketing, and manufacturing engineering departments.
- hierarchical integration, eg, in the structure of task and work organisation.
- changes in the linkage between manufacturing and business strategy, eg, what is to be made, for which markets, and how it is to be made.
- changes in the basic culture of organisations.

Characteristic of these is the idea of organisational integration to match the pattern of technological integration in the move towards CIM. Thus progress towards the future factory could be represented on a simple matrix (Figure Seven), which has as its axes increasing technological and organisational



**integration.** The goal - in which the full benefits of integrated systems are to be realised - involves integrated technology in an integrated organisation. The starting point for many firms is a basically dis-integrated pattern in both the use of discrete items of production equipment and in the extent of organisational integration. The question posed is how to get to the goal - and the suggestion is that, although pressure is strongly on for firms to choose the "technology first" route, their chances of successful implementation may be enhanced by following an organisations and technology route, or at least one in which organisations and technology are adopted in parallel with one another.

Figure Seven.

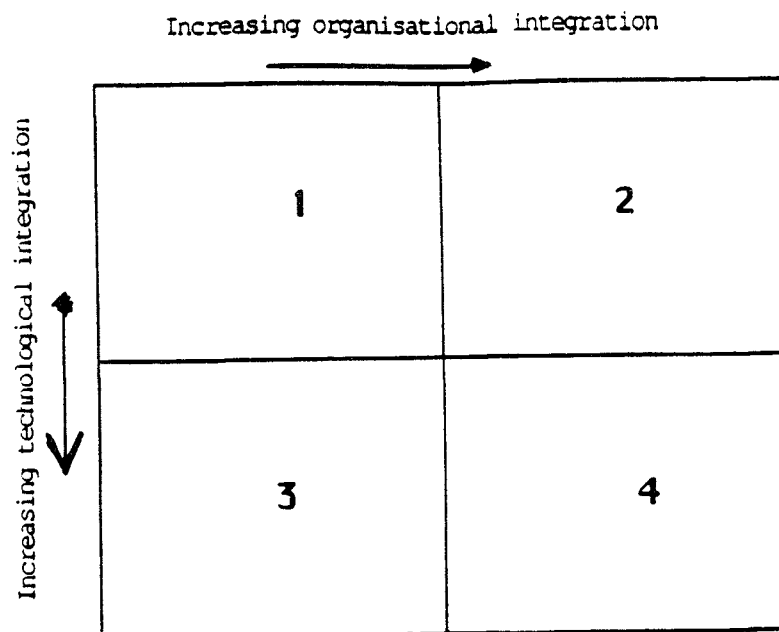

One final point concerns the strategic dimension. Much of the research, whether into the design and implementation of advanced systems or the organisational consequences of such innovations, has focused very narrowly on the production area. At worst systems are measured against purely technical and system specific performance criteria such as machine speeds and flexibility. For a few systems some form of performance appraisal pre and post installation takes into account some of the wider benefits to the manufacturing system (such as improvements in lead times, inventory levels or machine utilisation); although even here many benefits were unanticipated whilst other, expected benefits failed to materialise. But very few firms extend their appraisal to the strategic domain and look at the contribution of such new technologies to a manufacturing strategy which is also linked to an overall business strategy. As Voss (34) points out, there is an urgent need to plan investments at this level, to appraise their financial implications with this length and breadth of a strategic overview rather than a narrowly short-term one, and to assess the effectiveness or otherwise of the investment post installation against these strategic criteria.

REFERENCES.

- (1) Boaden R, & Dale, B: "What is C.I.M.?"  
International Journal of Operations Management.  
Vol' 6, No3. 1986.
- (2) Bessant J.R & Haywood, B.W: "F.M.S as an example of C.I.M"  
Innovation Research Group, Brighton Polytechnic. U.K  
Occasional Paper No1. 1985.
- (3) Kaplinsky, R: "Automation: The Technology and Society"  
Longmans. 1984.
- (4) Williamson, O.E: "Transaction Time Economics: The  
Governance of Contractual Relations"  
Journal of Law & Economics. Vol' 22, No11. 1979.
- (5) Solow, R.W: "On Theories of Employment"  
American Economic Review. Vol' 70, No1. 1980.
- (6) Lamming, R: "The Impact of Technical Change upon the  
Buyer-Supplier Relationship"  
Proceedings - Managing Advanced Manufacturing Technology  
Warwick University. 1986.
- (7) Dore, R. "Goodwill and the Spirit of Market Capitalism"  
Journal of Sociology. Vol' 24, No4. 1983.
- (8) Haywood, B.W: "Organisational Aspects of F.M.S in the U.K"  
Proceedings - New Systems of Production.  
E.C.E-Fast. Turin. 1986.
- (9) Perez, C: "Microelectronics, Long-waves and World  
Structural Change."  
World Development. Vol' 13, No3. 1985.
- (10) Dosi, G: "Technological Paradigms and Technological  
Trajectories".  
Research Policy. No11. 1982.
- (11) Kaplinsky, R: "Economies of Scale & Economies of Scope"  
Institute of Development Studies.  
Sussex University. 1986.
- (12) Senker, P. & Beesley, M: "The Need for Skills in the  
Factory of the Future".  
New Technology, Work & Employment. Vol'1, No1. 1986.
- (13) Fleck, J: "The Employment Effects of Robots" in,  
T Lupton (ed') Human Factors in Manufacturing.  
I.F.S Publications, Bedford. U.K 1984.

- (14) Voss, C: "Implementing Advanced Manufacturing Technology: A Manufacturing Strategy Perspective".  
I.F.S Publications, Bedford. U.K 1986.
- (15) Handke, G: "Design and Use of F.M.S"  
I.F.S Publications, U.K 1983.
- (16) Brodner, P: "Skill-Based Production: The Superior concept to the Unmanned Factory". in, H-J Bullinger & H Warnecke (eds') Towards the Factory of the Future. Fraunhofer-I.A.O  
Springer-Verlag, Stuttgart. 1985.
- (17) Wall, T: "New Technology and Skills"  
Manpower Services Workshop, Aston University. 1986.
- (18) Senker, P. & Beesley, M: Op Cit.
- (19) Arnold, P.E & Senker, P: "Designing the Future: The Skills Implications of Interactive C.A.D".  
Engineering Industry Training Board. Watford, U.K  
Occasional Paper No9. 1983.
- (20) Handke, G: Op Cit.
- (21) Driscoll, J: "The Use of F.M.Ss".  
Industrial Studies Department.  
Liverpool University. 1984.
- (22) Bessant, J.R & Chisholm, A.W.J: "Human Factors in the Implementation of C.I.M".  
18th C.I.R.P Seminar, Stuttgart.
- (23) Blackburn, P. et al: "Technology, Economic Growth and the Labour Process".  
Macmillan. 1985.
- (24) Report: "How Australian Industry Points the Way on Kanban"  
Production Engineer. 1984.
- (25) Report: "Just-in-Time: On the Move and out of the Aisles in America".  
Manufacturing Engineering. 1984.
- (26) Report: "Could the Kanban Production Control System Work Here?".  
Production Engineer. 1984.
- (27) Schonberger, R.J: "Japanese Manufacturing Techniques: Nine Hidden Lessons in Simplicity".  
Macmillan/Free Press. 1982.

- (28) Haywood, B.W: "F.M.S and the Small to Medium Sized Firm".  
Innovation Research Group. Brighton Polytechnic, U.K  
Occasional Paper No9. 1986.
- (29) Schonberger, R.J: Op Cit.
- (30) Ingersoll Engineers: "Integrated Manufacturing"  
I.F.S Publications, Bedford. U.K 1983.
- (31) Bessant J.R & Haywood, B.W: Op Cit
- (32) Dempsey P: "New Corporate Perspectives in F.M.S" in,  
K Rathmill (ed). F.M.S-2 Conference  
Proceedings.  
I.F.S Publications, Bedford. U.K 1983.
- (33) McCracken, J: "Exploitation of F.M.S Technology to  
Achieve Strategic Objectives". in,  
K Rathmill (ed). F.M.S-5 Conference  
Proceedings. 1986.
- (34) Voss, C: Op Cit.
- (35) Ingersoll Engineers: Op Cit.
- (36) National Economic Development Office: "The Impact of  
New Technology on Engineering Batch Production"  
N.E.D.O London. U.K 1984.
- (37) Haywood, B.W & Bessant, J.R: "F.M.S in Sweden and  
the U.K: A Question of Attitudes"  
Innovation Research Group, Brighton Polytechnic. U.K  
Pending.





**STRATEGIC OPTIONS FOR THE INTEGRATION OF  
PRODUCTION PROCESSES ON FIRM LEVEL (CIM)**

1. What is 'Computer Integrated Manufacturing'?
2. Different CIM-strategies and alternatives to CIM
3. Demands on human-oriented CIM concepts
4. Is it possible to establish human CIM concepts with today's technical means?
5. An example for the need for additional technical developments to realize human CIM concepts

Contribution to the December 1986 meeting of the  
CEC-FAST working group on  
'New Production Systems'

by

Gunter Lay

Fraunhofer-Institut für Systemtechnik  
und Innovationsforschung (ISI)

Karlsruhe, January 1987



## 1. What is 'Computer Integrated Manufacturing'?

Computer application in production planning and production departments of the plants themselves have increased continuously during the last few years. Using the keyword "computer aided manufacturing", the firms installed computer numerically controlled (CNC) machine tools and flexible manufacturing systems on their shop floors. Computer aided production management systems were introduced to assist material requirements planning and capacity planning. Furthermore, in the planning departments the work planning, especially the programming of CNC-machine tools, is nowadays equipped with computer aided systems. In product design and development processes the firms increasingly use computer aided design (CAD) systems.

These kinds of computer aided systems have until now been more or less limited to the borders of firm departments. The exchange of information between the departments and their computer systems was organized in a conventional way: drawings, bills of material, work plans, etc. were produced with computer assistance and then handed to the places where they were to be used.

The idea of computer integrated manufacturing (CIM) is to bridge these gaps between departments working with computer aid by linking hardware and software. The aim is to link grown islands of computer application in the firms. Chart 1 shows this in detail. It is noticeable that CIM is not one software system but a variety of single elements designed in a specific way to link already installed systems. Such elements are for example:

- Interfaces between CAD systems and systems for the programming of CNC-machine tools for geometric data exchange;
- exchange interfaces for geometric data between design systems and calculation systems;
- transfer links from CAD systems to material requirements planning systems for bills of material or for using parts from a computer aided inventory control in the design process;
- interfaces between shop floor data collection systems and capacity planning systems;

- direct numerically control systems to interlink computer numerically controlled machine tools with programming and program managing systems.

All these interlinks follow two principal ideas:

- Creating an uninterrupted digital information flow between all computer assisted technical and administrative departments of a plant.
- Avoiding multi-programming and multi-keeping of the same data in the memories of the computer systems in different departments.

Chart 1: Information exchange interfaces in CIM-concepts

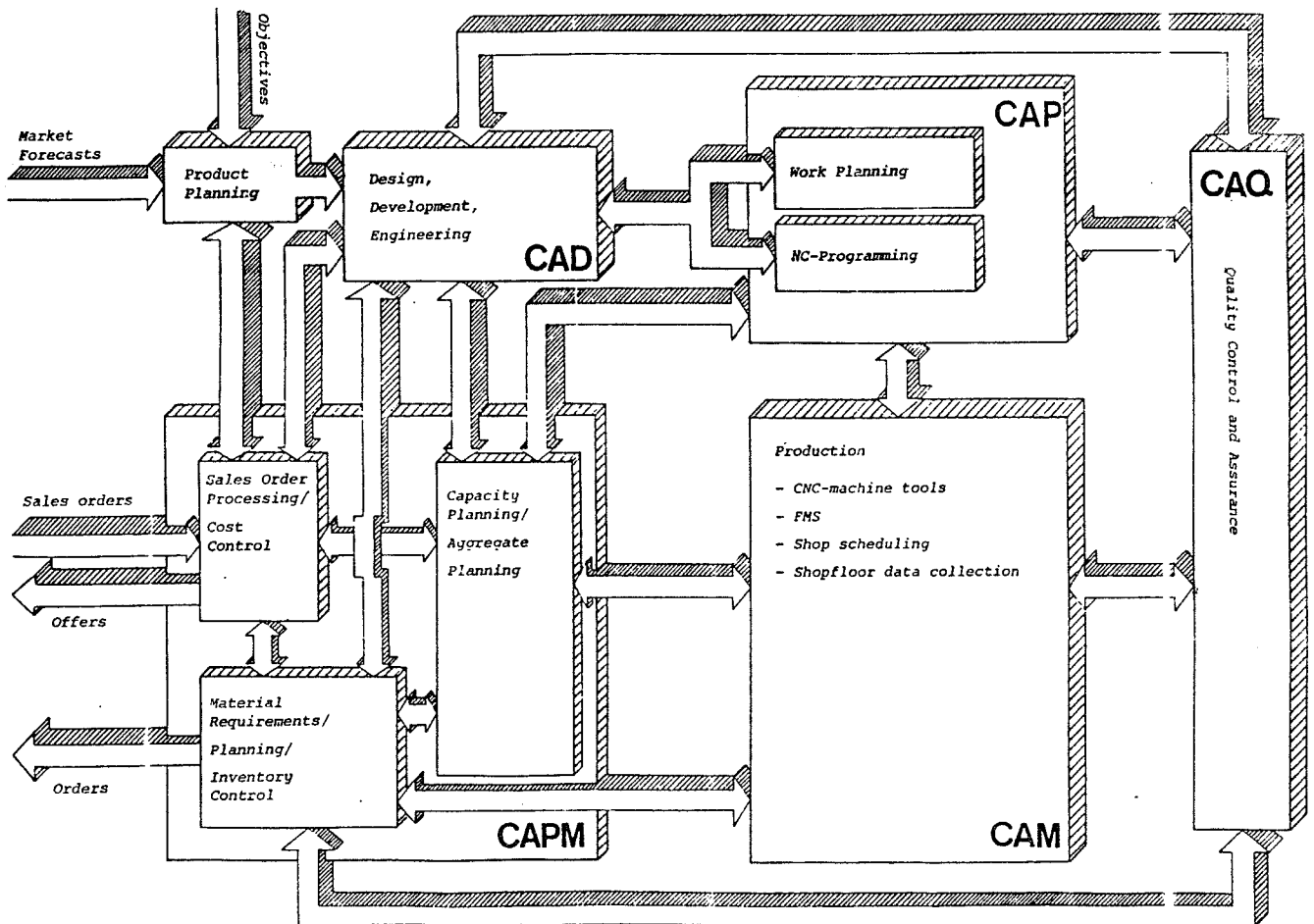

## 2. Different CIM-strategies and alternatives to CIM

The realization of computer integration between the different computer systems installed in all departments of a firm brings economic benefits for the enterprises by reaching the aims characterized above. For example, the interlink between computer aided design and computer aided programming of numerically controlled machine tools shortens the programming times, reduces the possibilities of making mistakes in the programming process and accelerates the throughput times by using the geometric definitions out of the CAD systems. An additional programming of the same geometric data of the workpiece in the NC-system can be avoided.

Having this background information and remembering

- the economic potential that therefore can be realized in future by the integration of computer systems,
- the enormous amount of subsidies that the individual countries and the European Commission invest in this technical development and
- realizing the state of diffusion reached so far

it is not realistic to believe that a now started discussion on the desirability of CIM in society would have effects on industrial practice. Even if such a discussion process lead to a broad agreement in social science that CIM concepts should be denied, the decentralized decisions on CIM investment and the different definitions of CIM would prevent any effects in restraining the further diffusion of CIM.

But CIM does not look like a technical trend that is necessarily connected in every case with bad effects on human work. Like most of the new technical developments computer integration in manufacturing can bring out completely different effects: On the one hand, the technical concepts and the organisational implementation of CIM in firms can be formed in a way the the computer integration over the borderlines of firm departments is another step towards centralization, increasing division of labor, dequalification, etc. But this scenario is not the only one possible.

On the other hand, it is also a realistic scenario that the CIM potential is used in a way that combines economic benefits for the firms with technical and organizational structures that favor qualification processes, holistic job structures, the ability to make decisions in the different workplaces, etc. In the following chapter some principles are described for designing CIM concepts of the second scenario. Out of these principles needs for additional technical developments will be printed out.

Up to this point, one thing in my opinion should be stressed: The discussion on old and new concepts of production to which many people contribute with different terms for the different concepts is not a discussion about the yes or no on computer integration. CIM is not the same as the "technocentric production concept". On the other hand, the "anthropocentric method" of organizing production does not necessarily mean a production without computer integration. The "anthropocentric production concept" has to use the chances of computer integration in supporting its aims by technical means. It has to form the principle concept of computer integrated manufacturing by bringing in its requests in development and implementation.

### **3. Demands on human-oriented CIM Concepts**

In the following chapter several elements that should be part of such CIM concepts which are not only economically centered but which also favor human aspects will be described. Some of these aspects, I believe, can at last be put into reality because the possibilities of CIM enable organizational structures which the traditional forms of computer application prevent. The elements listed are not really grouped systematically and distinguished in definition. They are the results of a brainstorming process and should be used as input for further discussions.

- The architecture of the computer system in CIM should not be a mainframe concept. Decentralized computers linked in a local area network bring a lot of advantages for the people working with the system. Some of these are the possibility of tailor the decentralized computers exactly to the needs of the different users, the shorter times of computer reaction, the independence from central computer maintenance staff, etc.

- The data base in CIM concepts that is created, administrated, distributed and used by different departments in the firms should have only one format. If this is not the case, there is the necessity for processing the data structures so that the data created in one department can be used in another. Such processing hinders communication in CIM. By processing of data structures the technical concept often creates one-way connections between the CIM components. That means the people working with the CIM components in the individual departments have closer limitations for decision making.
  
- The different components of CIM, that is the software modules for different tasks in CIM, should have a common "human interface". The structure of commands, the dialogues, the reactions of the system and so on should be standardized. Holistic job structures often request that the employees use more than one CIM component. Thus differences in the software dialogues hinder such structures of job design.
  
- The software architecture in CIM is to be formed so that decentralized decision-making is supported. Decisions aided by CIM should be made on the workplace where the effects resulting out of the decision can be judged best. Realizing that principle, it is possible to adjust competence and responsibility.
  
- The work organization in CIM and therefore the CIM architecture, too, is to be formed in such a way that individual qualifications of the employees can further be used in the same departments. Task shifting by CIM architecture from one department with qualified people to do these tasks to another department should be avoided. Otherwise, this would lead to dequalification.
  
- In structuring the CIM data base an attempt should not be made to collect and centralize all information of a plant in one big memory. In contrary, it has to be assured that from the single CIM workstation only that part of the information which is actually needed by others to do their work is handed to the higher level in CIM architecture. The benefit of such a tree-like concept is dual: the amount of data that is to be kept in central memories remains in a form that can be handled. Besides, the individual employee on his CIM workstation is not kept under permanent control.

- The possibilities of CIM should be used to create holistic job structures. Within the framework of integrated systems adequate competence structures are best to be established by regrouping the departments in vertical organization. For each product or group of products in a firm the people working in design, planning and production should be linked closer together.
- More than in the past CIM offers the possibility to support the so-called concept of design, planning and production islands.
- Training programs are necessary to give the employees transparency of information processing in CIM. Only this transparency enables workforce to fully use the scope they have in decision-making.
- CIM concepts should have a form in which the decision-making by humans is supported, not the automated. This means, for example, that CIM systems offer simulations of the consequences of different decision alternatives to aid the decision-maker.

#### **4. Is it possible to establish human CIM concepts with today's technical means?**

The realization of the demands listed above on human CIM concepts requires several preconditions:

- On the one hand the CIM components which are offered on the hard- and software market have to have certain options. The technical standard of these products must reach a level that makes it possible to realize in industrial practice what is possible to do with CIM in principle.
- On the other hand human CIM concepts, which can be established in principle and after specific technical developments for industrial practice, too, are an object of bargaining processes in firms. In these bargaining processes power balance, goodwill, thinking in short or long terms and other factors play a role.

On the part of the technical preconditions the following of the above listed demands can be realized in industrial practice because of the "state of the art" of the market supply:

- It is possible to decentralize computers. There is a tendency towards work-stations or even to the increasingly powerful personal computers. Mainframe computers are used more and more for data keeping and network managing.
- There is a supply side on the software market that offers software modules for CIM concepts by which the process of aggregate planning is aided on a central level and the process of shop scheduling is assisted on a decentralized level.
- The market offers not only software that tries to automate decision processes by mathematical algorithms but also software products which simulate the consequences of decision making alternatives for the user.

With this background on the market situation the "state of the art" suffers in the following areas. In these fields the present software supply of CIM components hinders the realization of human CIM structures:

- Common data structures, especially between CAD-systems and for example material requirements planning systems, are not available.
- Common "human interfaces", i.e. "man-machine dialogue", etc., have not yet been developed for the CIM components. Even within one CIM component there is a broad variety of dialogues which different vendors offer.
- Certain interfaces for data exchange which would allow to realize alternative forms of CIM are not available. The vendors partly offer software solutions for CIM concepts which are interconnected with specific organizational solutions.

In the following last chapter an example shall be outlined in which a human-oriented CIM concept could be realized if additional technical developments were started.

## 5. An example for the need for additional technical developments to realize human CIM concepts

In the last few years "shop floor programming" of CNC machine tools has established itself in Germany to a reasonable percentage beside the central computer aided programming. Under the aspect of keeping a high level of qualification on the shop floor and under economic aspects, too, shop floor programming is regarded in some cases as superior.

For the future it is quite doubtful whether the economic advantage of shop floor programming will remain. By an integration of CAD and computer aided programming of CNC machine tools in CIM concepts the programming times will become shorter. Until now the integration interfaces are available for CAD systems and central NC programming systems only. Therefore there will probably be a stressed trend to central NC programming. The limited importance which shop floor programming has reached will diminish.

This trend is, however, not inevitable. The following consideration may point it out: in Chart 2, two alternative concepts are shown which enable the exchange of geometric data of workpieces between CAD systems and the shop floor. To realize these interfaces additional work in developing is required. The task is to transfer geometric data out of CAD systems into shop floor terminals or computer numerically control units of machine tools.

If we are successful in the technical realization of such concepts and in proving the economic advantages of such concepts in industrial practice, shop floor programming even in CIM could have a chance in the future. The requirement is that the lead which central NC-programming systems have gained, is made up as quickly as possible.



Chart 2: Concepts for exchange of geometric data between CAD and shop-floor-programming

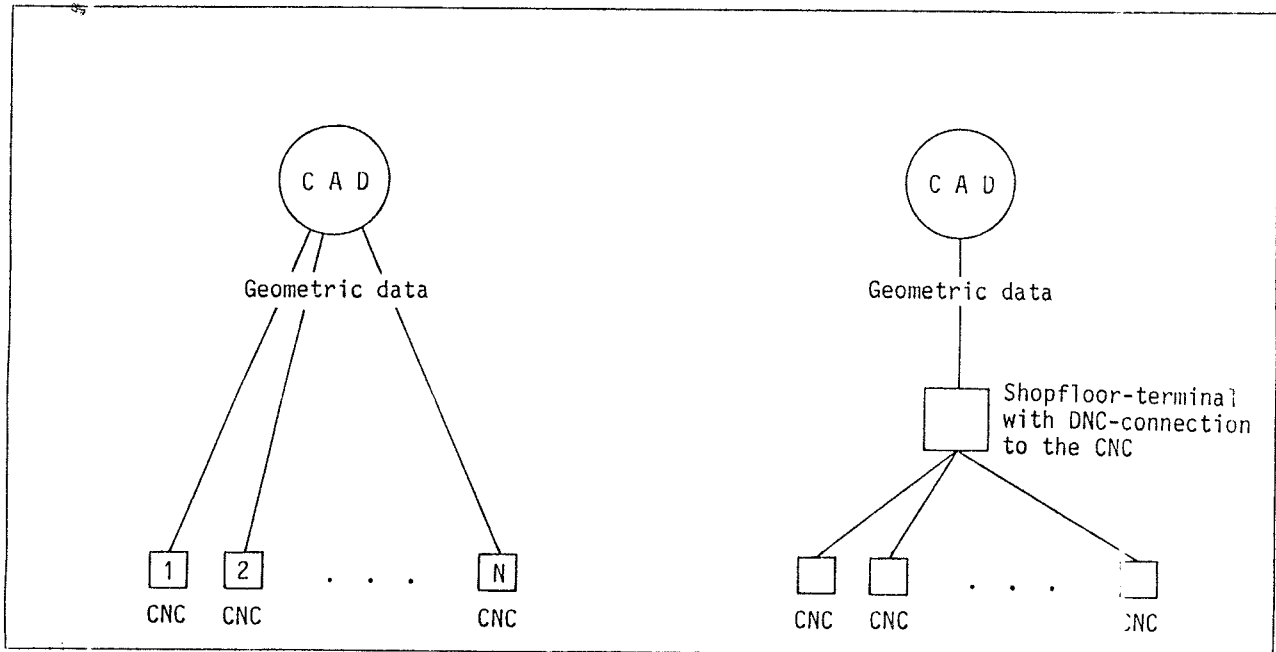





Fred Manske  
Soziologisches Forschungsinstitut  
(SOFI)  
Göttingen

ALTERNATIVE STRATEGIES OF PRODUCTION  
PLANNING AND CONTROL (PPC)

Contents:

1. Old and new ways of controlling production in the engineering industry
  - 1.1. The "foreman organisation" and the "piecework system" as "classical" planning and control systems in engineering firms
  - 1.2. Computer-aided PPC-systems as the new way to organise production
2. Alternative strategies in the use of PPC-systems: Total planning versus framework planning
3. Total planning or framework planning - which will prevail?
4. Recommendations

## 1. Old and new ways of controlling production in the engineering industry (1)

Shrinking markets and new technology seem to be leading to a new orientation in production strategies - the "end of mass production" appears to herald the "end of Taylorism" (cf. Piore/Sabel 1984).

If this is true, then the factory organisation of the future can possibly be prognosed from the present situation in the engineering industry. For the engineering industry produces by the "classic" method of small-batch production (most firms are in addition relatively small). The degree of division of labour is therefore also relatively small in engineering: This increases the chances that here the "human-centered approach" (cf. Brödnert's contribution) can be continued further so to say as a development of the current rationalisation practice. Perhaps even to the extent that it can serve as a model for the mass production industries which are heaving to adjust to the markets.

It is true that this will not happen automatically: The well known computer-aided technologies (CAD, CNC, CAP etc.) can especially in engineering be used in a Tayloristic way - to some extent in this case the mass production industries would provide a (bad) example for engineering. This contribution is intended to show that also in connection with PPC-systems (2) there are obviously two possibilities for use: One is more Tayloristic, it concerns the management concept of "centralistic total planning and control". The other concept is that of "framework planning and control"; this concept can be harmonised with the human-centered approach.

### 1.1. The "foreman organisation" and the "piecework system" as "classical" planning and control systems in engineering firms

It's necessary to deal first with the "classical" concept of "Production Planning and Control" in the engineering industry.

It is true that Taylorism, as a particular road towards the centralistic control of the work process, forms the centre of gravitation for all approaches to rationalisation in industrial production and was (perhaps still is) the general "ideology of rationalisation". However, as a concrete recipe for rationalisation and basically measured from its effect only in mass production, particularly the automotive industry, Taylorism has been able to win through. The Taylorism however has not in practice been able to win through in the engineering industry (which is one of the fundamental sectors of industry in Western Germany and in Europe).

---

1) This contribution is based on the results of an empirical investigation into the use of computer aided PPC-Systems in mechanical engineering firms in West Germany. The research projekt was financed by the Federal Minister for Research and Technology (Cf: Manske/Wobbe 1984; Manske/Wobbe 1986; Manske 1986 a,b).

2) Chart 1 in Lay's paper shows "islands of computer application", his CAPM is more or less identically with PPC.

## Why was Taylorism not able to succeed in engineering?

- It failed already from the obviously absurdly high costs which would have been required to organise effective job-planning departments (as well as various control points in manufacture).
- Perhaps a more theoretical reason is more important. As an expert in metal-cutting, Taylor himself investigated how many variables the "best" method of processing a workpiece depended on, and emphasised that each change in a variable would also alter the "best" method. Such changes however occur continually in the complex small-batch method of mechanical manufacture. And an essential variable -- which Taylor failed to see plainly -- is the worker himself, or his knowledge, which in principle is expanded continuously through his work. The failure of Taylorism to succeed is due finally to the continually changing preconditions of production. They cause what can be designated as the specifically empirical or experimental character of engineering work.

In engineering therefore the activity of work planning departments was basically limited to a precalculation, i.e., to a rough estimate of the costs of processing a workpiece on a machine.

The traditional form of organisation of work in engineering firms was the so-called "foreman organisation" (Meisterwirtschaft). It gave the control of production to the foreman and the workers. The process of production, that is, which machines would be used in which sequences in processing the components, was only roughly pre-planned. The way of working at the individual machines has hardly been prescribed for the machine operator, who is usually an experienced skilled worker. Job planning was limited to fixing the "allowed" time, the operator worked "from the blueprint".

Under this system the foremen in the machine shops had to allot work which, to a large extent, is the reason for their strong position in relation to the workers. For the most part the workers were given parcels of tasks which - unless more urgent jobs came up - they were able to carry out relatively independently. They were more or less indirectly "guided" by the piecework system: This piecework system was the essential "steering system". It implies a sequence of carrying out individual jobs in which, to save re-tooling time, the individual machine would be "optimally" organised by the operator. Workers (and foremen) acted according to their own strategies. The total process of manufacture was in principle of no interest to them, although of course there had to be a certain amount of coordination between assembly and machine production. There was, however, always a certain amount of "chaos" present in this method of control. It was, for instance, typical that some parts were constantly unavailable when they were urgently needed for assembly; an integral part of this system is therefore the "component tracer" who has to "track down" the missing components.

The firm profited in this control system from a relatively high utilisation of machines and relatively low machine and work costs per production unit. On the other hand, from the point of view of management considerable disadvantages resulted from the fact that the piecework system stood in the way of the desired integration of the total process. For the management in the final analysis manufacture

was a black box. Production knowhow mainly lay with the workers as the "foremen" of their own workplaces. The piecework system was therefore a "steering system" in the sense that it represented a compromise in the question of the wage/output regulation, and was at the same time a substitute solution for the centralistic control of work which would in the final analysis not be attained.

All in all, there exist in "classical" engineering firms consensual relationships between management and workers or the employees altogether. This is the consequence of the management's being dependent, because of the particular form of practical-experimental work in engineering, on the cooperative readiness of the labour force - the work cannot be preplanned without any hiatuses. The planning and the carrying out of an activity to a considerable extent form a single unit.

## 1.2. Computer-aided PPC-Systems as the new way to organise production

Computer-aided production control permits for the first time the promise of success for a centralistic command grip, and at the same time means a change of form in the approach to control. Compared with Taylorism, the new aspect of this command grip consists in the fact that no attempt is made to lay bare the core of the work process. Such a direct command grip is found in Taylorism (Manske 1986 a). In comparison, computer-aided production control is to be seen rather as an indirect approach to the control of production or the work process. The application of this control takes place so to say around the "core of the work process". (1)

### 1) A note on the expression "core of the work process":

It is usual to emphasise the separation of the planning and controlling activities from those of the actual carrying-out of the work as being the central component of Taylorism (Bravermann 1974). However the specific point about Taylorism is perceived as a whole only when the "atomistic" method of proceeding contained in this approach is seen in the planning and control of the production process: every detail of this process is supposed to be analysed and "scientifically prepared", in order subsequently to synthesise a plan out of the individual elements. So far as the analysis of the work of the direct producer is concerned, Taylorism aims through this at making the production knowledge of the workers available centrally, so that each minute particle of this knowledge is "expropriated" - the "secret" of how the work is carried out is to be totally exposed. Workers however continually build up additional and important production knowledge as practical know how, "tacit knowledge". The expropriation of production knowledge thus involves a continuous storage of ongoing new "zones of uncertainty" (Crozier, Friedberg 1979) - or laying open the core of the work process.

The essential components of the new approach are:

- the allocation of very small volumes of work to the workers; they are given stocks of work which can be accomplished in one or at most two days. In extreme cases they are allocated only one task at a time.
- There is a tendency, by means of data collection in the firm, to make the times necessary for each task more precise through immediate registration of the start and finish of the jobs.
- In addition, important events, such as defects in material, lack of material, machine stoppages and the reasons for them, absence of workers and the reasons, etc., can be registered by means of the firm's data collection, above all for the purpose of eliminating disruption.
- The piecework wage system is replaced by a mixture of time-wage systems and bonus schemes. Apart from other reasons, the change in wage form is good from the point of view of management because the more exact centralistic control of the production process in this way becomes more consensual, since in principle small allotments of tasks and stricter controls are not able to be combined with the piecework wage system.

These are the contours of the new approach for the planning and control of the production processes. Besides the fact, that PPC-Systems can be used in different ways - cf. the next chapter - all computer-aided PPC-Systems have the following effects: With PPC it is for the first time possible to undertake extensive plans for capacity use, sales order processing, inventory control and to plan sequences of work in detail.

Market conditions and deficits in autonomisation of the production process from the workers are responsible for the fact that as previously the workers still possess some own relevant "control zones". But those control zones have been greatly reduced in comparison with earlier periods. In brief: With PPC-Systems a highly effective control over the process - and over men! - as intended by management is achieved by better planning, organising, steering and control of the preceding and surrounding areas of production (i.e.: the core of the work process).

## 2. Alternative Strategies in the use of PPC-Systems: Total planning versus framework planning

With the introduction of PPC-systems the following economic results are in particular expected by management:

- reduction of throughput times;
- better observance of delivery dates;
- reduction in stocks of semi-finished products and bought-in components;
- increase in the capacity utilization of machines.



The Question is: How can we achieve those results, how can we utilize the enormous new potential for planning and control production.

Is it possible to schedule production by computer so accurately that this schedule only needs to be executed? This seems to be the outstanding problem for many software developers and firm management. Such an approach amounts to reducing production control to a technical problem. I wish to demonstrate that such a technical view of control problems in mechanical engineering is inadequate; production planning and control cannot be separated from the "social relationships" within the firm (just mentioned above), and if technocratic solutions lead to less than optimal results, this is not entirely due to computing problems. In order to show this I will now outline the two different concepts of PPC: The centralistic total planning and the framework planning, coupled with decentralised responsibilities.

If we look at the control concept of centralised total planning, we can designate it as an attempt to organise complex small-batch production in a way similar to large-batch production. To the advocates of this concept it is precisely the new computing potential which appears to be appropriate for producing the transparency which in mass production can be achieved by the narrowly prescribed production methods, by extreme division of labour in assembly, by an exact scheduling and by the strictly specified organisation of the processing sequence. There was, however, a demand to go beyond this and to "depersonalise" control. The central know how which is already present in production (with foremen and machine operators just as much as with workshop management) and which was already partially available centrally, was to be computerized. It was expected that this would contain adequate planning possibilities to make individual machine production centrally controllable.

However, in most firm where attempts were made at such an approach, it very soon appeared that precise sequence planning was only applicable to a very limited extent. The reason for this lies not with computing itself but very often with programmes which are usually unable to cope with production requirements. Standard programs, at least, too closely copy the structure of mass production.

In spite of such deficiencies, centralised total planning is still a prevalent orientation. "At least make a start" is the motto of the advocates of this philosophy. The recognisable deficiencies of deterministic scheduling were to be balanced by more planning. By the expansion of production data collection (PDC) and a changeover to a realtime processing of collected data, it is believed that planning can adequately be adapted to changed conditions. The claim is maintained that the workshop should not carry any orders unless a precise planning has previously been undertaken. With PDC, every event in the workshop was, as far as possible, to be planned in respect of time and without any errors. Only in this way can planning be kept up to date.

At the level of the employee, this concept leads to a detailed scheduling of single tasks. Total planning also implies of necessity a strict control of workshop employees, not only workers but

also foremen and even control personnel. It is no exaggeration to say that "even the allotment of work is predetermined, so that the functions which remain consist only of carrying out work and reporting it back" (Bechte 1980).

The centralised total planning concept stands in contrast to one which links a central framework planning with decentralised, personal detail planning and not only execution of plans. It can be described as a "search for the middle road". In this case, production control only offers a loose framework plan which is to be detailed in the workshop. Central framework planning means that dates for execution of jobs are calculated, optimised and centralised by means of basic computing routines. In contrast to the foremen system, this means in particular the use of the integration potential of computers. The sequence of deadlines becomes more reliable for the foremen and more transparent for the central station. In this concept certain planning barriers of mechanical production are accepted and no attempt is made to produce a complete pre-planning of the production process. If the attitude of total planning is in principle an attempt to adapt production of planning, then the attitude of framework planning is an attempt to maintain existing advantages of the structure already present and includes it as an element of the planning concept.

This approach differs fundamentally from total planning. The philosophy of total planning implies a central plan, prepared prior to manufacture, and also that the production plan is strictly enforced. According to the decentralised approach, planning is a process which must include the skills on the shop floor. The plan is not completely prepared before production; it rather merges successively, and never so completely that it represents full and detailed instructions to the workshop on how to proceed. Production control is a synthesis of computing capacity and personnel capacity.

### 3. Total planning or framework planning - which will prevail?

If the observations made in the course of the survey are correct, then the first phase of the almost euphoric introduction of computer control systems in mechanical engineering firms has today been replaced by a phase of sobering up. The contrasted concepts point to two paths which further development could follow. Which is the more likely? We can get nearer an answer to this question if we remember that rationalisation barriers in mechanical engineering are, on the increase. Machine production can be only to a degree planned in advance, since

- the sequence of operations for mechanical processing cannot always be exactly and in detail predetermined;
- allowed times cannot be exactly determined, and "actually required" times can differ from the guidelines in incalculable ways;
- market demands can have their effect, so that manufacture may be begun even though the product has not been thoroughly designed in detail and/or only rough plans or none at all have been prepared;

- market demands make subsequent changes unavoidable;
- market demands continually create urgent orders - for instance for the delivery of spare parts - which cannot be postponed and for which only a limited stock can be kept;
- technical problems, such as the breakdown of a machine, can be reckoned only as an average but not calculated in detail; if one particular machine is out of production for a couple of days, there is no point in the breakdown having been correctly calculated as "average" in the long term;
- errors in planning (for example, wrong designs) and deficiencies in organisation (for instance, materials not being available when they are required) cannot be excluded in the complexity of machines or sequences of operations, nor can they be anticipated with precision;
- planning of sequences can take no account of the state of the workers or of known attitudes or accepted claims. The state a worker is in can affect his productivity; he is not a machine which can go on working continuously and at the same level. Attitudes include such facts that, for instance, workers often need a certain time first thing in the morning before they get going, and it is unfortunate if the first job in a deterministically planned sequence turns out to be a "problem case". One component of accepted claims is for example that after completing a "bad task a worker is given a "good" one;
- only to a limited extent can workers be moved around to different machines. The machines usually require a certain time for familiarisation which is the foundation of efficient use. The use of stand-ins, now on one machine, now on another, has its limitations in small-batch production in mechanical engineering, which means that for economic reasons staff can be adapted to an inflexible sequence plan only to a limited extent.

What remains as an argument in favour of total planning? The barriers to planning which have been outlined rather contribute to the conclusion that mechanical production can in general not be forced into the bed of Procrustes represented by a deterministic total planning.

Basically it is technical reasons (the complexity of the product and the limits of technical automation) and market conditions (the trend towards production which follows the solution of individual problems) which restrict the ability of mechanical production to be planned. The complexity of production leads to the firm remaining dependent upon the technical skills of the workers and the foremen, and upon their motivation: The workers must be taken seriously as "producers" by the firm, their dedication is essential for production to function.

With this inclusion of the skills of foremen and workers, with the conscious recognition of the "producer role" of the workers under the aspect of increasing production efficiency, the "social character" of mechanical production is fully appreciated. Our investigation shows that a rigid planning concept which does not officially envisage the contribution by workers and foremen as well as control personnel from the start, is liable to provoke negative reactions. As a consequence, planning can quickly turn into a "world of unreali-

ty" which differs considerably from the actual scheduling in force. In addition, where the social needs of the workshop are insufficiently taken into consideration, bureaucratic behaviour and working-to-rule are provoked. The "social character" of mechanical production has therefore the same basic roots as its limited plannability; it indicates that the technical and organisational problems of machine production lead the mechanical engineering firms to having to enter upon compromises with the workshop in a specific way, which must also be considered as a precondition in devising control systems.

References

- Bechte, W. (1980), Steuerung der Durchlaufzeit durch belastungsorientierte Auftragsfreigabe bei Werkstattsteuerung, Diss. Universität Hannover.
- Bravermann, H. (1974), Labor and Monopoly Capital, New York, London.
- Crozier, M., Friedberg, E. (1979), Macht und Organisation, Die Zwänge kollektiven Handelns, Königstein/Ts.
- Manske, F. (1986 a), Computer-aided production control - a new road to a centralistic command of the production process?, Paper presented at the EG-Symposium "New Production Systems", Turin.
- Manske, F. (1986 b), Produktionsplanungs- und -steuerungssystem in Klein- und Mittelbetrieben, KfK PFT Bericht, Bd. 128, Karlsruhe.
- Manske, F., Wobbe, W. (u. Mitarbeit von Mickler, O. (1984), Rechnerunterstützte Systeme der Fertigungssteuerung in der Kleinserienfertigung - Auswirkungen auf die Arbeitssituation und Ansatzpunkte für eine menschengerechte Arbeitsgestaltung, KfK PFT Bericht Bd. 90, Karlsruhe.
- Manske, F., Wobbe, W. (1986), Total ore Framework Planning? Alternative Systems of computerised Production Control in Mechanical Engineering, in: Human Systems Management 6.
- Pabst, H.-J. (1985), Analyse der betriebswirtschaftlichen Effizienz einer computergestützten Fertigungssteuerung mit CAPOSS-E, Frankfurt, Bern, New York.
- Piore, M.J., Sabel, Ch.F. (1984), The Second Industrial Divide, Possibilities for Prosperity, New York.





**HUMAN CENTRED TECHNOLOGY, STRATEGIC OPTIONS AND USER'S CONSENT**

**Paper for the EEC-Workshop on  
"New Production Systems"  
Brussels, December 1986**

**Hans-Joachim Braczyk**



engineering industry which responded to the challenging changes of market conditions with the introduction of flexible automation technologies, becoming increasingly capital intensive and having shrunked the ratio of labour in terms of value as well as in terms of numbers (SORGE et.al. 1982; KERN u. SCHUMANN 1984; PIORE u. SABEL 1985) the clothing industry tentatively made use of the choice of organizational and skill resources to obtain a higher degree of flexibility, product quality, shortage of lead time and so on (KNESEBECK 1983).

As far as the German situation of the clothing industry is concerned most enterprises only could survive in a hard contested market by a shift from standardized mass production towards specialized customer taylored quality production. In conjunction with this new market strategy the clothing producers are faced with:

Smaller and smallest batch sizes;

Uncertain availability of materials (fabrics and others);

Increased variety of products (various colours, patterns, shapes);

Changed order behaviour of customers (wholesale and retail), careful pre-orders are followed by several and in both respect qualitatively and quantitatively different post-orders including modest alterations of various characteristics of the products;

High level quality standards are to be reached whereas an increasing variety of fabrics and other materials makes it much more difficult to meet quality standards within given piecework times.

These new market requirements enormously influence the production process. Because of specific obstacles the technical automation and integration of different functions is - at least - behind the state of the

art in most other industries (Neue Arbeitsstrukturen ...1983; BRACZYK et.al. 1984a). Clothing industry remains labour intensive.

In recent years most of the leading firms of the clothing industry introduced new types of work organization, such as working groups, in order to obtain more flexibility by organizational means. This way necessitates relatively high level of skills and improvements of working conditions. The design of work which has taken place during the last decade indicated different types of job enrichment and semi-autonomous groups. Shop floor workers' capability became a strategic key resource to several enterprises when they attempted to adjust work organization and skills of shop floor personnel to the new market requirements. These attempts included considerable enhancements of task elements of both horizontal and vertical functions. Labour force remained as the most significant source flexibility could derived from. The way the clothing producers had chosen, of course, was determined by a remarkably lagged technological development in terms of both process and organizational integration compared to other industries.

However, with the help of microelectronics production equipment becomes more flexible. Because of its capability microelectronically based technology will affect the new forms of work organization in the clothing industry. As far as the assembling and finishing sections of the production process (sewing, pressing, inspection) are concerned, more and more engineering manufacturers provide computerized unit production systems (UPS) in conjunction with conveyors having hangers with clamps or bundles in order to facilitate the integration of increased number and variety of product criteria - stemming from actual market requirements - into the production process. This leads to a certain extent to a renaissance of the so-called hanging manufacturing which means the connection of each work station by conveyors with hangers which according to the schedule provide the work stations with piece goods appropriately.

According to a supplier survey we recently conducted, in which eight out of ten responded, computerized UPS are designed to make the production process more suitable to increased flexibility demands due to new market conditions (BRACZYK et.al. 1987). Besides typical aims of rationalization, such as reduction of labour and capital costs, suppliers consider different needs of clothing producers in order to obtain much more flexibility in the manufacturing process, especially

- \* improved insight, information, and control
- \* reduction of throughput time
- \* optimizing management of the sewing floor, e.g. balancing the line.

With the help of computers (in most cases different kinds of PC applications) different work stations will be provided automatically only with those materials actually needed and the entire sewing line will be coordinated properly including high priority throughput of urgent orders, at least according to responses of the suppliers.

Our analysis of the systems under study focused on implications for work organization and skills. We looked at the extent to which the system configurations contain options and constraints, respectively, regarding different utilization patterns covering task definition, skill requirements, and autonomy of sewing personnel. In addition matters of data and information management including access to data related to the individuals have been considered.

The findings in general are impressive and have certain theoretical significance. Despite the overall accepted rejection of the technological determinism hypothesis there is no doubt that production technologies - at least those under study<sup>1</sup> - implicitly contain "prescriptions" on how to use them. We consider it important to clarify the - possible -

<sup>1</sup> However, we have further reason to support this hypothesis in the light of previous research results. Cf. BRACZYK 1985b, p. 262 - 277; BRACZYK et.al. 1984b.

impact of those prescriptions on work organization and skills. Although all system configurations under study aim at the same objective: to gain and to facilitate higher flexibility of the production process at sewing floor, as a result of our analysis we can clearly distinguish between types providing opportunities for task definitions on higher skill level as well as for extended disposition for the individual sewing worker and those which do not. It appears that there are options and constraints already embedded in system configurations of technology by suppliers.

Obviously, the design of work depends to a certain extent on the system lay out of the technology. But where do the points of reference for system lay out come from?

Referring to additional interviews with members of the technical staff of the suppliers included in the survey we can point out that there is very little technological dialogue between suppliers and users, as far as the clothing industry is concerned. Regarding the computerized conveyors in conjunction with UPS in several cases they have been created and developed by different clothing producers themselves because of a lack of appropriate machinery supply in the market. After having made positive experiences some of those clothing producers either changed business or became additionally an engineering manufacturer and brought their self-made systems into the market, suggesting that they will fit into almost every production line. This is one significant resource where concepts for the design of technology are derived from. Specific user experiences are generalized as if they are true for the whole industry.

Another resource for technological concepts, and this we consider as more important, is the market. In order to say it more precisely: The expectations suppliers have of users' expectations of how the market might be structured and on how an appropriate technology should look like. In this view technological concepts on the side of suppliers to a certain degree rely on interpretations of interpretations of interpretations.

For the moment I neglect the inherent vagueness of such technological concepts. First of all I pay attention to the mediating part of the market in the context of development and design of technology.

Rather simplifying it could be argued that the lay out of production technology is related to the dominating factors of the market. Of course, this argument is trivial as long as it relates to demand and supply relationships between engineering manufacturers and clothing producers. However, this argument seems to be true also with respect to strategic options in the use of technology. There is evidence that engineering manufacturers develop technology according to their own imagination about the most suitable means to meet actual market requirements the clothing producer is confronted with. To a certain extent the user becomes dependent on a hidden prescription about appropriate work organization and level of skills on shop floor. The supplier restricts the range of strategic options for the use of technologies on users' side. This must not be confused with technological determinism in the common sense. What is meant is that technology will be designed in the line with principals of work organization, division of labour, skill requirements etc. designers and/or suppliers refer to. This does not exclude necessarily the installation of such a technology within an organizational environment due to different or even opposing principals. But an adjustment of one of each to the other becomes rather probable.

Precisely with respect to technically embedded organizational principals the production technologies under study can be distinguished reasonably. The key criteria of distinction are:

Sufficient facilities for the sewing worker to interact with the system itself and with other work stations of the system as well according to his/her own disposal.

Ability, in general and for the worker in particular, of the computerized management control system for change of tasks at the same work station and change of work station for the same worker at any time.

System provided abilities for workers to arrange work by themselves at each work station.

Referring to the results given above and taking the two most contrasting types of supplied system configurations into account:

The *first* type by design permits both the use in a rigid Taylorian assembling line and in a restructured work organization consisting of different semi-autonomous working groups which perform at relatively high level of skill. In this case the real use depends on the choice the user is taking on how to use the system.

The *second* type is strictly designed according to the principals of a Taylorian assembling line without admitting any alternative.

In the interviews it came out that the system configurations of the supplied technologies have been designed correspondingly to the organizational concepts the suppliers would prefer if they were in the position of the users. In so far one can state: The more an engineering manufacturer believes in Taylorism at least in the sense that Taylorism might be the best way for the user to organize a rational production process the more the supplier will design technology in favour of technically provided flexibility at the expense of organizational flexibility. In fact, systems under study belonging to the second type are the expression of the belief Tayloristic production concepts can be further applied even under deeply changed market conditions of the clothing industry, if the work stations in the line are addressed more flexibly by technical means. On the other hand, systems belonging to the first type express uncertainty in this respect.

Uncertainty that means leaving the choice to the user. It is up to the user to take his selection out of the given, say incorporated, options the system configuration provides. This, of course, determines not at all which decision the user eventually will take. Again, it depends on his interpretation of the market conditions his enterprise is related to and on its organizational environment, including given labour force, as well.

## 2. Strategic options - how to use them?

In the case of our supplier survey there is no doubt that the market plays an important part in the systems lay out of new production technologies. Using strategic options in technological development therefore means the design of technology to a certain extent will remain within the context of those market conditions which are true or respectively considered as true for the products that will be manufactured with the help of these technologies. Engineering manufacturers, however, rarely are aware of the actual and the foreseeable market structure. They must rely on 'long distance interpretations'. This becomes even more significant if it is considered that suppliers must tend to provide technologies fitting to future market conditions users will be faced to.

The shape of market conditions may change. At present they, at least partly, support the use of strategic options in the design of system lay out which come close to the concept of human centred technology (BRÖDNER 1985). However, nobody knows whether the present conditions will remain unchanged.

Considering the inevitable vagueness interpretations of market requirements will contain one could ask which technological lay out by design would be the most suitable one. It could be stated: The more a technology by design is in the line with the user's concept of utilization, the less the user's organizational system will be restricted to technically 'predetermined' decisions on work organization, qualification structure and skill level (BRACZYK 1985a). We draw the conclusion that, from the point of view of the rationality of social systems, the

decision on the alternative between 'technocentric' and 'human centered' technology should not be taken on the design stage. This only would change the content of technically embedded prescriptions to the user as to how to utilize technology but would not eliminate the prescription itself. Since we believe that the realization of the concept of human centred technology necessitates consent of those who will actually use the technology in every day working life, we consider two alternatives to technically embedded prescriptions:

Design of technology in a way that the full range of different options for utilization with respect to work organization, qualification structure, and skill level will be built in. It should not be the designer but the user who takes the final decision on how to utilize the technology. The user will take this decision in accordance with his own perceptions of market conditions and necessities of the manufacturing process as well. This alternative could be called pre-decision-type.

The user conceptualizes previously to the design of new technology the organizational framework, qualification structure and skill levels. The technology then will be designed in accordance with the taken decision of the user which, in turn, corresponds to a specific consent constellation among actors and groups within the user's firm. This could be called the post-decision-type.

The user, of course, not at all is a single man - only by neglectable exception. The user rather represents an organization - a social system embedded in internal and external environments. The social system has its own dynamics (LUHMANN 1984;). Regarding the rationality of social systems the main question of technological development is whether technology should automatize social systems or support further evolution and differentiation of social systems.



### 3. Human centred technology

Coming back to the concept of strategic options in the use of technology. In the light of our own empirical results and research experiences we would like to stress:

There are indeed different options in the use of technology. For economic, social and human reasons it is highly recommendable to take use of them.

It is, however, more rationale to leave the decision on the use of different options to the user's system instead of imposing a unique alternative technological concept on the design departments of the supplier's system.

Just for the very reason that there are different options in the use of technology it is up to the users getting aware of the fact that there are choices to be taken. Criteria of selection must be tied up with the rationality of the user's organizational system.

Referring to the available knowledge on the relationship between technological change, work organization, and skills the following seem to form almost a rule: The more complex the technology is in terms of organizational integration, the more social prerequisites in terms of consent among the different actors, groups and institutions involved play a decisive part in the utilization of technology. Consequently, growing dependence on extra-technical prerequisites parallels the use of technology with increasing risks originated outside the technology itself. Obviously, on the design stage consent hardly can be anticipated. This consideration leads to the conclusion that development and design of technology must be based upon consent among the users and different actors concerned.

Users, in the meaning of social systems, must develop an adequate understanding of the function of social systems and should accordingly deploy appropriate technological concepts. It is the social system technology should fit to, and not the other way round. Most members of social systems obviously need help and support in obtaining this adequate understanding.

Additionally, the user consists of different social actors following different interests. It is important to employ consent among these actors. Thus, development and design of new technologies should become a genuine social process involving different members of a firm's organization and other relevant social actors related to the organization of work as well.

Since there is no longer any doubt about the fact that new, computerized, technology that share the property of being, at least partly, organizational technology, it is important to realize that there is an increasing need to tie up the use of technology with consent among users.

Obtaining consent will have the best chance, by empirical evidence, when the most significant actors that are anyhow involved will be coordinately related already to the conceptual work either previously to the technical design or to the user's decision on utilization. In other words: The new technology needs a new design in the sense that the conceptual work will be organized socially. It does not make sense to have a complex organization technology designed by technical concepts or, let us say, philosophies. The more organizational integration is emphasized the more even the designing part of the whole process of technological development needs a proper guidance as to how the technology would respectively could fit best into either the existing or aimed work organization, qualification structure, and skill level.

## References

- BRACZYK, H.-J., NIEBUR, J., WEISSBACH, H.-J. 1984a: Arbeitsorganisation und Lohnsystem in der Bekleidungsindustrie, ASIF-Forschungsberichte Band 1, p. 24 -26.
- BRACZYK, H.-J., NIEBUR, J., HEIDENREICH, M., MILL, U.: 1984b: Arbeit in Giessereien, Forschungsbereich "Humanisierung des Arbeitslebens" 01 HA 061 7, Universität Bielefeld.
- BRACZYK, H.-J. 1985a: Neue Technologien und alter sozialer Konsens - Eine zentrale Herausforderung an die moderne Industriegesellschaft. Vortrag zum Symposium: Die Industriegesellschaft vor einer neuen Epoche? 6. - 7. Mai, Gottlieb-Duttweiler-Institut Zürich.
- BRACZYK, H.-J. 1985b: Work in Foundries, in: Unattractive Work, Sofia, p. 262 - 277.
- BRACZYK, H.-J., GEBBERT, Ch., v.d. KNESEBECK, J.-H. 1987: Neue Transporttechnologien in der Bekleidungsindustrie, Arbeitsgruppe für Sozialwissenschaftliche Industrieforschung ASIF Bielefeld, VDI-Verlag, Schriftenreihe Humanisierung des Arbeitslebens, Band 85.
- BRÖDNER, P. 1985: Fabrik 2000. Alternative Entwicklungspfade in die Zukunft der Fabrik, Wissenschaftszentrum Berlin, Internationales Institut für Vergleichende Gesellschaftsforschung, Arbeitspolitik, Berlin.
- KERN, H., SCHUMANN, M. 1984: Das Ende der Arbeitsteilung? München.
- KNESEBECK, v.d. J.H. 1983: Gruppen mit erweitertem Handlungsspielraum als Lösungsansatz zur Humanisierung und Flexibilisierung, in: FISCHER et. al. 1983: Arbeitsstrukturierung und Organisationswandel in der Bekleidungsindustrie, Sozialforschungsstelle Dortmund, Campus Frankfurt/M p. 130 - 152.
- LUHMANN, N. 1984: Soziale Systeme. Grundriß einer allgemeinen Theorie, Suhrkamp Frankfurt/M.
- Neue Arbeitsstrukturen in der Bekleidungsindustrie 1983, Schriftenreihe "Humanisierung des Arbeitslebens", Campus, Band 39, p. 18 - 36.
- NIEBUR, J. 1983: Von der Wachstumskrise zur Schrumpfungindustrie - Strukturwandel in der Bekleidungsindustrie, in: FISCHER et. al. 1983, p. 20 - 36.
- PIORE, M.J., SABEL, Ch.F. 1985: Das Ende der Massenproduktion, Wagenbach, Berlin.
- SORGE, A., HARTMANN, G., WARNER, M., NICHOLAS, I. 1982: Mikroelektronik und Arbeit in der Industrie. Arbeitsberichte des Wissenschaftszentrums Berlin. Internationales Institut für Management und Verwaltung/Arbeitsmarktpolitik, Campus, Frankfurt/M.





STRATEGIC OPTIONS FOR HUMAN-MACHINE INTERFACE DESIGN

Martin Corbett

MRC/ESRC Social and Applied Psychology Unit,  
University of Sheffield,  
Sheffield, S10 2TN.

Contents

1. State-of-the-art and future trends in human-machine production systems
2. Major problem areas .....
  - (i) Reliability
  - (ii) Design of jobs
  - (iii) Interface design
3. Strategic options for research and development

## 1. State-of-the-art and future trends in production systems

Within the engineering community in Europe (and elsewhere) there persists a vision of "people-less" production systems of the future. In this view, the explicit incorporation of human factors in the design of production technology is a temporary and rather short term problem becoming increasingly redundant.

Such a claim for the future of production systems should be taken seriously, although it is hard to answer since it is probably the case that the evolution of such systems will be somewhat haphazard and unpredictable. In part this is due to the uncertain nature of technical innovation during rapid periods of change. But it is also due to the inevitable uncertainties concerning the diffusion of such technical changes. Nevertheless, one can make some reasonable predictions about the nature of change and speculate on whether or not, in the foreseeable future, the design of human-machine interfaces will remain relevant.

A number of trends can be discerned from the current pattern of change. Firstly, all commentators agree that the introduction of stand-alone CNC machine tools, CAD work stations and industrial robots will continue to accelerate. But at the same time, more and more companies will experiment with, and introduce, integrated systems such as FMS and CAD/CAM. Considerable effort will also go into developing Computer Integrated Manufacturing systems but, except in research and development cases and in some instances of highly predictable production environments, these will not extend to fully automated "people-less" factories on any widespread basis. In large part this is because reliable enabling technologies are not yet in place, and furthermore, most companies are simply unable to address the complexities involved, to say nothing of the expense, particularly in the field of systems integration. Overall, such systems as do evolve will get larger and, so far as both the designer and the user are concerned, more complex.

These opportunities will probably be greatest in small and medium batch production firms, which account for around 70% of British engineering output. Such innovations as are implemented will be operated in the midst

of relatively old technologies such that there will be "islands of production" amongst traditional technologies.

Human aspects of systems technology will thus remain important for the foreseeable future. In particular, as production systems get larger, more sophisticated and complex, they will need well trained personnel to run them. They will also need to be designed so that they are comprehensible to the operators if performance levels are to be satisfactory. We are now hearing talk of the "multi-skilled craftsman" in relation to new production technologies - craftsman capable of operating and maintaining complex electro-mechanical systems.

State-of-the-art production systems are Flexible Manufacturing Systems (FMS) which combine the benefits of a highly productive, but inflexible transfer line and a flexible, but relatively inefficient, job shop. An FMS is a system dealing with high level distributed data processing and automated material flow using computer controlled machines, assembly cells, industrial robots, inspection machines and so forth, together with computer integrated materials handling and storage systems. Such systems are typically centrally programmed with little or no part programming facilities available on the shopfloor.

The next generation of production system is the Computer Integrated Manufacturing (CIM) system. These systems extend integrated computer control to the ordering and re-supply of parts and materials and work scheduling.

## 2. Major problem areas

There are three, interrelated problem areas associated with the human-machine relationship which stem from the technical trends discussed above. These are:-

- (i) the reliability of new production technologies,
- (ii) the effect of these technologies on the design of jobs, and
- (iii) the design of appropriate human-machine interfaces.



### (i) Reliability and New Production Technologies

The historical trend in the design of shopfloor production work has been toward the incorporation of human skills into automatic machinery. The development of the digital computer and the microprocessor offers the potential to extend this skill incorporation to both physical and mental capabilities. The operators of state-of-the-art FMS technology are typically required to carry out those functions which are not yet automated. The current lack of technical sophistication in sensing devices and error recovery software has led to a concentration of human operators in monitoring and error recovery tasks. As such, individual vigilance and responsiveness is critical to overall system performance and the wealth of craft skills available in Europe remains under-utilised.

It is one of the great ironies of technological design that the human element is regarded as the major source of uncertainty in system performance (and therefore one to be eliminated whenever possible), whilst at the same time it is generally accepted that the operators' ability to cope with uncertainties and unforeseen disturbances during system functioning, is the factor governing system reliability. A further irony stems from the fact that, when software is developed to replace certain operator functions, this software itself tends to create uncertainties which are more difficult to control because they are less "visible".

The historical development of manual to automatic control of shopfloor machines therefore has an important consequence for the overall efficiency of production systems. In all realisable systems there will be some undesirable disturbance or noise which may enter the system at one or more points during the production process (e.g. poor castings, worn tooling). These disturbances can be eliminated in one of three ways.

1. Remove all disturbances at source (e.g. reject all sub-standard materials before they go on the shopfloor).
2. Predict all possible disturbances and develop software and hardware mechanisms to control them.

3. Utilise a skilled operator who, with an almost completely open-ended repertoire of skills and behaviour, will drive the production system to its goal despite unforeseen disturbances.

The predominant trend in engineering design, fuelled by the dream of the "people-less" factory, is to take the second option. This trend stems from a technology centred or 'technocentric' approach to technological design.

The development of solid modelling in CAD systems, which permits simulated metal cutting and the direct generation of part programs from geometric data, is widely heralded as an important key to the success of this strategy. However, the failure to design and develop a "people-less" factory at the present time bears witness to the complexities (and expense) involved in pursuing the totally predictable (reliable) production system. Indeed, many commentators are now fostering the belief that, as the complexities of production technology increase, the role of the human operator will become more, rather than less, important for efficient system functioning. In this view the design of operator jobs becomes a critical factor for system reliability.

A 'technocentric' approach to design, therefore, overlooks two factors. Firstly, that designer errors can be a major source of operating problems, and secondly, the designer who tries to eliminate the operator still leaves the operator to do the tasks which the designer cannot think how to automate.

The legacy of 'technocentric' design can be stated as follows: Having fragmented the job of the New Production System operator and removed a large part of his/her skilled control of the system, the designer then relies on him or her to deal with all unforeseen (unprogrammed) disturbances. However, a technical system that does not provide the experience out of which operating skills can develop will be vulnerable in those circumstances where human intervention becomes necessary.

Take, for example, the Direct Numerically Controlled (DNC) machine tool which is a basic building block of second and third generation 'technocentric' systems. Here, almost all uncertainty and discriminatory

choice is removed from the operator because the program that controls all the machine functions is written away from the machine by an office programmer. The high cost of such machines and the subsequent high value of the finished product are such that it is important to keep the machine running and to avoid scrapping. As virtually all disturbance occurs at the machine (Corbett, 1985) the operator sometimes has to override the program. But a DNC lathe is designed primarily as a machine-workpiece system rather than a human-machine system and it is more difficult to avoid making control errors because shopfloor intervention was not explicitly designed for.

#### (ii) New Production Technology and the Design of Jobs

Whereas traditional manual and semi-automatic production technologies enabled manual skills to be incorporated into the design of machines, the development of the digital computer and the microprocessor enables human cognitive and decision-making skills to be complemented or replaced by machines. It is the historical trend towards this incorporation of human manual and cognitive skills into machines which is equated, by many writers (e.g. Braverman, 1974), with the historical tendency towards the simplification and fragmentation of manufacturing shopfloor jobs.

Empirical research on the impact of new production technology on the design of jobs has not lent support to this deskilling theory, but it is important to note that studies which offer counter evidence are predominantly case studies of jobs with stand-alone CNC machine tools. Although CNC machines are the basic building blocks of new production systems, they are not integrated together by computer control systems or automatic materials handling machines as are the next generation FMS and CAD/CAM systems. Hence the CNC case studies "are all sampling organisations/firms at a particular historical point, one in which the form of the technology has not been closed off by a series of decisions and technical developments which, in combination, constitute sunk costs such that unwinding them, making a series of different choices, becomes an impossible cost burden" (Littler, 1983: 144).

There is growing awareness that the designers of the second and third generation technical system designers are the job designers of the future and there is therefore an urgent need for occupational psychologists and other personnel experts to become involved in the design of such systems at the earliest possible stage.

There are two distinct options open to systems designers at this point in time. One which is currently dominating design thinking can be termed the 'technocentric' approach to design. In this perspective, the aim of automation is to displace human skill and place it within the technology. Typically, the allocation of functions between human and machine is based on the idea of comparability - functional requirements being realised with respect to the technological stage of the art, where the human takes over those functions that are not yet solved. But, as Rasmussen (1979) has argued, "The fact that all control functions which can be formally described also can be automated by means of computers, leads to the danger that the role of the system operator will be to plug the gaps in the thoroughness of the designer's work. On the one hand, as a convenient, movable manipulator, he will have a category of trivial, infrequent actions for which automation is unfeasible; on the other hand, as an intelligent data processor he will be expected to respond to ill-structured and unforeseen tasks" (p.2).

The impact of 'technocentric' production technology on the design of jobs is one in which human operators are increasingly becoming subordinate to machines: humans become passive as machinery takes a more active controlling role in the production process. The development of 'Fifth Generation' Intelligent Knowledge Based Systems (IKBS) enables this impact to be all the more pervasive.

In the occupational psychology literature there is now mounting evidence that this automation of discretionary skills traditionally exercised by manufacturing shopfloor personnel has a detrimental effect on both the physical and mental health of these personnel (e.g. Karasek, 1979). Furthermore, research in cognitive and developmental psychology suggests that the loss of control that is experienced by many operators of second and third generation production systems may well spill over into

their home and social lives to create a state akin to 'learned helplessness'.

The alternative, 'anthropocentric' approach to systems design rejects the idea of human-machine comparability and focuses instead on how they may complement each other. The computer and the human mind have different but complementary abilities. The computer excels in analysis and 'number crunching' computation, whilst the human mind excels in pattern recognition, synthesis and intuitive reasoning. By combining these different abilities in technological design it is possible for humans and machines to help each other achieve an effect of which each is separately incapable. It is to this endeavour that the human sciences need to contribute through involvement in technological design. Present and future strategies for this endeavour are discussed later in the paper.

#### (iii) The Design of Appropriate Human Machine Interfaces

One of the problems associated with 'technology-centred' systems is that their operation often requires skills that are unrelated to existing skills, with the resultant problems of poor transfer of training and the under-utilisation of the rich seam of machining skills to be found in Europe.

The development of CNC technology has produced a shift in decision competence from human to machine, whereby the operator of a machine tool, for example, is not alone in the control of the machine but, owing to the decisions and choices taken by the designer and stored in the computer, he or she is now forced to co-operate intimately with the designer.

The number of design decisions and choices open to the designer is almost infinite, but research in the field of ergonomics points to three key choice points in design which have the most impact on operator skill and control. These are:

1. the allocation of function between human and machine,
2. the control characteristics of the human-machine interface, and
3. the informational characteristics of the human-machine interface.

With regard to the first of these choice points - the allocation of functions - ergonomists stress that there are choices over what humans do and over what machines do in any automated system. The conventional 'technocentric' approach to this choice is to leave the operators only those tasks which cannot be automated. The irony of this approach has been discussed in the previous section.

This approach to the allocation of functions typically leads to the concentration of operator tasks in monitoring and error recovery functions. Where an automatic control system has been put in because it can do the job better than an operator, the operator is also asked to monitor that it is working effectively. In complex modes of operation the operator will need to know what the correct behaviour of the production system should be. Such knowledge requires either special training or special information displays.

The alternative 'anthropocentric' approach to function allocation needs to be based on the idea of human-machine complementarity as discussed above.

A second key choice point in technological design concerns the control characteristics of the human-machine interface. Design decisions here concern how the control of the production system is to be shared between human and machine. For example, CNC machine tool control software can be designed to enable operators to interrogate data bases in order for them to take important controlling decisions (such as determining tool path geometric, work scheduling and pacing). On the other hand, the software may contain complex algorithms which enable the computer to take all the controlling decisions, thereby restricting the operator's role to that of machine minding.

Rosenbrock sees two paths open to designers in respect of the control characteristics of New Production Systems technology, corresponding to the 'anthropocentric' and 'technocentric' distinction made above. Using the example of Computer Aided Design (CAD) technology, Rosenbrock describes one approach (the 'anthropocentric') as involving the acceptance of the skill and knowledge of the designer and attempting to give the designer improved techniques and facilities for expressing that skill and knowledge. Such a

system would amount to a truly interactive use of computer technology that allows the very different capabilities of the computer and the human mind to interact to the full. The alternative, 'technocentric' approach, to this is "to sub-divide and codify the existing design process incorporating the knowledge of the existing designers so as to reduce it to a sequence of simple choices" (Rosenbrock, 1977). The 'anthropocentric' approach therefore places the human in control of the system, whereas the 'technocentric' approach reverses this and leaves the human subordinate to the system.

The third key choice point in systems design concerns the informational characteristics of the human-machine interface. The invisibility of many software functions in complex production systems means that the operators must rely heavily on information and data that is transmitted or generated by computer in order to structure their work behaviour. Software which only presents machine-specific information to an operator in the event of system malfunction, for instance, will not enable the operator to see the overall consequences of his or her actions for overall system performance. Restricting information in this matter inevitably restricts operator control as one can never fully control a system without understanding it.

The interaction between human and computer may thus be viewed as a social interaction between operator and designer, in which the designer predefines the situation through the type and scope of the information given to the operator. Because of this, the designer has a further means to restrict or enhance operators' control of a production system. One has only to recall Milgram's (1974) dictum: "Control the manner in which a man interprets the world, and you have gone a long way toward controlling his behaviour".

An operator will only be able to generate successful new strategies to control disturbances if s/he has an adequate knowledge of the production system functioning during the production process. Bainbridge (1983) points out two problems this creates for 'machine-minding' operators. One is that effective retrieval of knowledge from long-term memory depends on frequency of use. The other is that this type of knowledge develops only through use and feedback about its effectiveness. Theoretical knowledge

of a production system is not enough - even relatively simple 'unskilled' production work requires the vital input and use of operators' tacit knowledge and skills (Kusterer, 1978).

The relationship between the three key design choice points discussed above and the design of shopfloor work may be summarised as in the table below. This table compares 'technocentric' and 'anthropocentric' approaches to the design of New Production technology. This table illustrates that the design of an 'anthropocentric' human-machine interface involves both software and hardware considerations.

DESIGN CHOICE POINT	TECHNOCENTRIC DESIGN	ANTHROPOCENTRIC DESIGN
Allocation of functions	Humans do that which can not be automated. Choice determined by analysis of human-machine comparability. Rigid allocation of functions.	Machines do that which is routine and uncreative. Choice determined by analysis of human-machine complementarity. Flexible allocation of functions.
Control characteristics of human-machine interface	Computer in control of machines through the use of formalised programmed actions and strategies. Human limited to monitoring and error recovery tasks.	Human in control of machine through the use of varied repertoire of skilled actions and strategies. Computer limited to decision support functions, such as simulation of alternative strategies.
Informational characteristics of human-machine interface	Information exchange restricted by design. Predominance of VDU as medium of interaction.	Information exchange maximised by design. Tacit knowledge and skills a fundamental aspect of interaction.



### 3. Strategic Options for Research and Development

Given the technical and social advantages of 'anthropocentric' New Production Systems technology, there are now two main areas of R & D that need to be addressed. Firstly, there is a growing need for these advantages to be communicated to engineering designers, production engineers and organisational decision-makers. Although the intransigent conservatism of many of these job holders is, undoubtedly, one factor which has contributed to the present failure of such a communication, organisational and occupational scientists themselves must shoulder some of the blame.

At present in the UK, and other European countries, there is little social science research taking place into the human and social aspects of New Production System technology. This is probably due to three inter-related factors, namely a shortage of funding for social science research generally, the lack of recognition amongst social scientists of its importance, and a shortage of skills in this area.

Within individual companies, the picture is scarcely any better. Many engineers are loath to adopt more organisational and psychological views in their work, especially when these extend to areas which are difficult to quantify. At the same time, other professional groups, such as line managers, general managers and personnel/industrial relations specialists, are reluctant to adopt a more proactive role in the design, development and implementation of technology, preferring to leave these issues to the technical specialists. Similarly, eventual users and their representatives rarely put these items high on their agendas, perhaps because their interest in new technology is dominated by whether or not it affects their job security and job prospects.

The second area of R & D that needs to be addressed is the need for the 'anthropometric' perspective to shift from its theoretical and philosophical critique of current practice, towards a more practical and proactive role in technological progress. One of the most productive ways of making this shift may be through the design, development and implementation of alternative 'anthropocentric' technology in the 'real

world' of manufacturing. Through the implementation of exemplary 'anthropocentric' systems, the benefits of such technology can be demonstrated to all.

Such a shift will not be made without difficulties, and there is therefore an urgent need for research and development into the process of designing these alternative systems. Rhetoric needs to be backed up by constructive example.

### Proactive Research and Development Work

This method of working involves the explicit consideration of the human aspects of New Production technology from the beginning of design. Whilst work scientists have had very little involvement in work of this kind, some notable efforts have been made in some areas and virtually none in others. Some examples are offered below.

#### Collaborative Design Methods

Overall research into designing 'anthropocentric' New Production Systems is on a minute scale compared to the amount of research being carried out on their 'technocentric' counterparts. There are, however, notable attempts to develop collaborative design methods, which need to be developed and extended. **[Recommendation 5.1].**

A pioneering example is the UTOPIA project which was based at the Swedish Centre for the Quality of Working Life in Stockholm (Ehn, Kyng and Sundblad, 1982). UTOPIA is an acronym in the Scandinavian languages for Training, Technology and Products from the Quality of Work Perspective. This project involved the design of powerful computer-based tools for skilled graphic workers in the newspaper industry, and utilised a radical new approach to the design process. This approach was essentially experimental and involved experienced end-users, i.e. skilled graphic workers, in the design process. The emphasis was on 'designing by doing' using mock-ups and rapid prototyping.

In the U.K., the best known example of this kind of proactive R & D work is that based at the University of Manchester Institute of Science and Technology (UMIST) under the leadership of Rosenbrock (1983). This project involved the development of a flexible manufacturing system in which operators are not subordinate to machine, although in practice much of the work focused on developing human-centred software for a CNC lathe. This work is now being extended by funding from ESPRIT to incorporate the wider field of Computer Integrated Manufacturing systems. As in the UTOPIA project, the research team undertaking this work comprised work and social scientists collaborating with computer scientists, skilled workers and engineers.

Experiences within these projects suggest that social scientists should not concentrate solely on the drawing up of human-centred work design criteria in the hope that engineers can and will use them in the way that is desired. Design is not merely the application and trading-off of design criteria: intuition and aesthetic considerations play an important role in the design process. Accordingly, the use of scenarios, rapid prototyping and design mock-ups may prove particularly useful in counteracting the dominant technology-centred approach to engineering design.

### Control System Design

The field of human factors engineering (ergonomics) potentially has a major input to make to 'anthropocentric' control system design, but, at the present time, the predominant emphasis in ergonomics research has been at the informational level of systems design (the third key design choice point identified in the previous section). The output from such work is 'user friendly' software and it is rare that the more fundamental control aspects of the human-machine interface are studied. It is also unlikely that such research will be funded from the normal human factors funding bodies. Hence R & D work on the control aspects of human-machine interaction, such as the direct manipulation of New Production System machinery, has progressed little since the pioneering work on Record-

Playback machine tools control systems and analogic part programming techniques at the M.I.T.

R & D work on the design of control system technology is important because, although CNC machine tools generally have some provision for shopfloor part programming and editing, the development of DNC is liable to push these functions back to the office (as they were with NC). This push will receive further impetus as CAD solid modelling techniques are refined and developed. **[Recommendation 5.2].**

### Information System Design

The highly integrated systems architectures associated with FMS and CIM technologies necessitate research effort in the area of distributive information networks as well as decentralised control systems (q.v. chapter by Gunter Lay). We have already stressed the impact of system complexity on the design of shopfloor work, and it seems likely that a decentralisation of information and control will be a crucial element in the usability and flexibility of New Production Systems.

The UMIST project illustrates how information that has traditionally been kept in the hands of the production department may be presented to shopfloor personnel via terminals located at the machines in a way that is compatible with traditional machining skills and decision making. In this example, the emphasis was on information concerning the determination of cutting parameters and sequences, but there seems to be no reason why this principle should not be extended to include information on overall system performance, targets, scheduling priorities, tool path geometry and so forth. **[Recommendation 5.3].**

The development of expert systems and artificial intelligence techniques is another crucial element in the design of future production systems. The announcement from Japan of the Fifth Generation initiative created a response in Europe based on the perceived need to compete, rather than a critical evaluation of whether such technology was suitable for European needs. Certainly, in the manufacturing arena, much of Japan's New Production Systems technology is designed to incorporate human

machining skills because of the chronic shortage of skilled craftsmen. Europe, on the other hand, has a wealth of craft experience and expertise to tap. It makes sound economic sense for technology to be developed in Europe which allows this important human resource to be expressed and not displaced.

### Design of human-machine dialogue structures

The continuing trend in 'technocentric' design towards the centralisation of programming activities means that very little research and development effort has been concentrated on the design of human-machine dialogue structures for shopfloor programming and decision-making. Many such designs impose a fixed sequence of actions and strategies on the user which may be inappropriate to cater for actual, rather than normative, production demands.

Work on direct object manipulation and on user-definable macros offers encouraging signs that flexible and reliable dialogue structures can be designed which allow skilled machinists to follow their own preferred methods and sequence of working. **[Recommendation 5.4].**

### References

- Bainbridge, L. (1983). Ironies of automation. Automatica, 19, 775-779.
- Braverman, H. (1974). Labor and Monopoly Capital. New York: Monthly Review Press.
- Corbett, J. M. (1985). Prospective work design of a human-centred CNC lathe. Behaviour and Information Technology, 4, 201-214.
- Ehn, P., Kyng, M. & Sundblad, Y. (1982). The UTOPIA Project. In Briefs, Ciborra and Schneider (Eds.), System design with, for, and by the users. Amsterdam: North Holland.
- Karasek, R. A. (1979). Job demands, job decision latitude and mental strain: Implications for job design. Administrative Science Quarterly, 24, 285-308.
- Kusterer, K. (1978). Know-how on the job: The important working knowledge of unskilled workers. London: MacMillan.

- Littler, C. (1983). A history of new technology. In G. Winch (Ed.), Information technology in manufacturing processes. London: Rossendale.
- Milgram, S. (1974). Obedience to Authority. London: Tavistock.
- Rasmussen, J. (1979). Notes on System Design Criteria. mimeo. RISO: Danish Atomic Energy Commission.
- Rosenbrock, H. H. (1977). The future of control. Automatica, 13.
- Rosenbrock, H. H. (1983). Social and engineering design of an FMS. In E. A. Warman (Ed.), CAPE '83, Part one. Amsterdam: North-Holland.



**PART 3**

**RECOMMENDATIONS**



## LEVEL ONE: OPTIONS FOR CIM

1. Profoundly changed market requirements due to the shift from steady expansion to tendencial stagnation have a strong impact on production processes. While adapting them, the specific conditions, strengths and weaknesses of the European industrial structures must be considered. They indicate that future manufacturing technology, work organization and skill profiles have to be developed according to the requirements of "flexible specialization" or "diversified quality production", where Europe appears to be superior. Instead of merely imitating Japanese production systems, it is a question of survival for the European industry to develop its own manufacturing technology suited to its specific conditions and needs.
2. In order to make productive use of human skills and to efficiently organize production along the lines of "flexible specialization", group technology principles - i.e. grouping parts in families, grouping machinery and personnel for complete manufacture or design of these families, integrating design, planning and controlling tasks with operating - have to be applied to the shop floor and the technical office. In this context integrated computer assistance has to be implemented in a new way, however. Instead of concreting and incorporating almost all knowledge and the sequences of work as far as possible in the computer system, in this case the computer serves as a general, actual and consistent information system also performing routine operations, leaving the planning of working actions to the workers' and designers' skills.

3. Work design - i.e. the determination of the division of labour, of the allocation of functions between human and machine and of the modes of human-machine interaction - has to be done in such a way, that in the working situation a wide margin of action is being preserved leaving initiative, evaluation and decisions up to the worker, and that his work comprehends planning and executing tasks. So that in this situation the computer can be used as a tool, its functions and its behaviour have to be completely transparent. Particularly, its reactions have to be self explaining and adapted to the actual working situation. In interaction it is extremely important that the worker can perceive the connection between his own intention or action and the effects it produces.

Accordingly, an appropriate user surface of the technical equipment is needed. The human-machine interaction therefore has to be designed in a way that it is

- transparent and self explaining  
(by use of direct object manipulation),
- adjustable to different degrees of user's experience  
(presenting flexible dialogue procedures),
- reliable (following the principle  
"what you see is what you have got").

4. There are manifold resistances against change resulting from the hardware and software installed, the social system with its positions and privileges, the industrial relations, and the prevailing ideology. Therefore, the transition to new production systems can only be achieved, if, first, the traditional thinking that the replacement of humans by machines be the only improvement of production is surmounted by thorough analysis and assessment of alternative production concepts, and if, second, a strategic plan for the transition comprising the development of work organization, skill profiles and technology is worked out, bargained between and agreed upon by all interest groups affected.

M. Corbett

Recommendations for R & D Action in Human-Machine Interface Design

5. Research into alternative design methods involving the incorporation of human and social factors right from the beginning of design, and not only at the implementation stage (as at present). Mechanisms whereby end-users and their representative bodies can collaborate with design engineers require particular study. Such mechanisms may include the use of scenarios, design 'mock-ups', rapid prototyping and 'brainstorming'.
6. R & D work on the construction of technological control systems which enable the user to use his or her skills and allow them to develop. These skills include both manual and decision-making components. Ways in which software may be used to support human decision-making, through the utilisation of simulation and fast feedback, merit particular attention.
7. Research into the design of information displays and interactive graphics which enable skilled craftspersons to see and understand the workings of the overall system. The should be interactive, and part of a lateral (as opposed to hierarchical) information network to maximise shopfloor intervention and involvement.
8. Research into the design and use of human-computer/human-machine dialogue structures which do not impose a fixed, sequential method of data exchange between human and computer/machine, but allow the user to follow his or her own methods of working. Work on direct object manipulation and user-definable macros appears to be the most promising approach to this problem.

G. Lay

Recommendations

9. - The architecture of the computer system in CIM should not be a mainframe concept. Decentralized computers linked in a local area network bring a lot of advantages for the people working with the system. Some of these are the possibility of tailor the decentralized computers exactly to the needs of the different users, the shorter times of computer reaction, the independence from central computer maintenance staff, etc.
10. - The data base in CIM concepts that is created, administrated, distributed and used by different departments in the firms should have only one format. If this is not the case, there is the necessity for processing the data structures so that the data created in one department can be used in another. Such processing hinders communication in CIM. By processing of data structures the technical concept often creates one-way connections between the CIM components. That means the people working with the CIM components in the individual departments have closer limitations for decision making.
11. - The different components of CIM, that is the software modules for different tasks in CIM, should have a common "human interface". The structure of commands, the dialogues, the reactions of the system and so on should be standardized. Holistic job structures often request that the employees use more than one CIM component. Thus differences in the software dialogues hinder such structures of job design.
12. - The software architecture in CIM is to be formed so that decentralized decision-making is supported. Decisions aided by CIM should be made in the workplace where the effects resulting out of the decision can be judged best. Realizing that principle, it is possible to adjust competence and responsibility.
13. - The work organization in CIM and therefore the CIM architecture, too, is to be formed in such a way that individual qualifications of the employees can further be used in the same departments. Task shifting by CIM architecture from one department with qualified people to do these tasks to another department should be avoided. Otherwise, this would lead to dequalification.

14. - In structuring the CIM data base an attempt should not be made to collect and centralize all information of a plant in one big memory. In contrary, it is to be assured that from the single CIM workstation only that part of the information which is actually needed by others to do their work is handed to the higher level in CIM architecture. The benefit of such a tree-like concept is dual: the amount of data that is to be kept in central memories remains in a form that can be handled. Besides, the individual employee on his CIM workstation is not kept under permanent control.
15. - The possibilities of CIM should be used to create holistic job structures. Within the framework of integrated systems adequate competence structures are best to be established by regrouping the departments in vertical organization. For each product or group of products in a firm the people working in design, planning and production should be linked closer together.
16. - More than in the past CIM offers the possibility to support the so-called concept of design, planning and production islands.
17. - Training programs are necessary to give the employees transparenence of information processing in CIM. Only this transparenence enables workforce to fully use the scope they have in decision-making.
18. - CIM concepts should have a form in which the decision-making by humans is supported, not the automated. This means, for example, that CIM systems offer simulations of the consequences of different decision alternatives to aid the decision-maker.
19. In the following fields the present software supply of CIM components hinders the realization of human CIM structures:
  - Common data structures, especially between CAD-systems and for example material requirements planning systems, are not available.
  - Common "human interfaces", i.e. "man-machine dialogue", etc., have not yet been developed for the CIM components. Even within one CIM component there is a broad variety of dialogues which different vendors offer.

- Certain interfaces for data exchange which would allow to realize alternative forms of CIM are not available. The vendors partly offer software solutions for CIM concepts which are interconnected with specific organizational solutions.

## Recommendations

## 20. The development of framework planning requires research

Computer aided PPC-Systems are necessary for general planning of deadline and capacity over longer periods. In the meantime a number of things have happened in this field, but the problems have by no means all been solved. Here further research appears absolutely essential. It should and must be oriented on the specific problems of small-batch production and those of small firms.

The reason for this orientation on the specific problems of smaller firms and of small-batch production lies in the fact that many of the well known systems (total planning systems) are either not at all or only partially suited to aid planning and steering of the production processes in firms with individual or small-batch production.

## 21. Shop floor planning within the frame of centrally controlled order pools

Workers should be regarded as actors in the PPC-system at their workplace. They should be given (or retain) the right to complete the "final detailed planning" over a set period of time, which should be at least one day and preferably two.

This so-called shop floor planning is compatible with the workers

- being given urgent orders, by the production steering department, which need to be given priority in processing following agreement, and
- being given directions concerning priority or sequence by the firm as a request.

The final right of disposition must however - for priority or sequence directions - remain with the worker.

It is important to bear in mind that this form of shop floor planning (with worker as actors of the PPC-System) is in the first place a question of organisation and not of PPC hard-core software.

But there are some developments of PPC-systems which use the "tacit knowledge" of the foremen and the workers by leaving to them decisions about the sequence of work within limited periods of time.

- These systems are intended to make information available in order to support decisions by the users (for instance by showing quickly and unambiguously on the terminal the consequences of postponing a task).
- The decision and planning responsibility remains with the users, e.g. foremen and/or workers: algorithms are no more included in the system which "automatically" provide a decision.

These new systems make high demands on the creation of software ergonomics, amongst other things because they should be only sporadically used in addition to their "actual" tasks by the users.

#### 22. "Lenient" controls as a compromise in data collection and processing in firm

The coupling of personal data and productivity data should be excluded. The individual registration of the beginning and end of each task should be replaced by the registration of finished packages of tasks. That means: Details are in general not automatically collected via terminals but are reported by the worker at the end of the shift. Such relatively loose controls are sufficient for the completion of orders on time and also for cost-accounting.

#### 23. Production islands as a concept for shop floor planning

The idea of (autonomous) production islands goes far beyond the suggestions presented up till now. It has been considered as a model for a far-reaching self-organisation of work in industrial production (and assembly).

In our opinion this concept is particularly applicable to small firms in the engineering branch, where it is not so much a matter (as it is in larger firms) of undertaking a reorganisation of production means from the aspect of technological groups. In small firms the whole mechanical production (and the assembly), with perhaps 10 to 20 workers, can basically be regarded as an "island" (Manske 1986 b). (1)

#### 24. The economic advantages of framework planning

In the points a. - b. indications were given both for the research as well as for organisation of PPC-use in a factory. The question remains of the economic efficiency of the concept framework planning for the use and the further development of PPC - and not least as an important example for the human centered use and development of computer-aided technologies.

- 
- 1) When dealing with research and development it should be taken far more into consideration than up till now that the greater number of firms in industry (at least in the FRG) are small firms with less hierarchical structures than large firms. It is however the major firms which to a great extent decisively influence the software development (for instance in the PPC field).



In chapter 3 arguments were presented for the economic superiority of framework planning over total planning. A recent case study in an engineering factory has again shown concretely the deficits of total planning in mechanical engineering. The author, the head of the planning department of that factory, arrives at the conclusion that framework planning is to be economically preferred to total planning. This is of course no final prove of the superiority of framework planning - but regarded in connection with the increase in support for framework planning it goes some way towards showing that the human centered path is the right one (cif. Pabst 1985).

H. Braczyk

### Recommendations

25. In order to realize the concept of human centred technology the need for user's consent must be considered. For that reason two types of technological development and design should enjoy privileged support in terms of financial aid by national and EEC authorities:

pre-decision-type, that means the development and design of technology (including steering systems, data and information management and software in particular) which provides the full range of options in the use of technology, leaving the final decision on utilization with respect to work organization, qualification structure and skill levels to the users;

post-decision-type, that means the development and design of technology in accordance with a specific user's conception of utilization based upon consent among different user groups.

Advantages and disadvantages of each type should be investigated in the course of appropriate experiments.

26. Recognizing the functional relationship between user's consent and human centred use of technology development and design of new technology should be organized as a social process. It is recommended that user groups first of all should determine the kind of work organization (including horizontal and vertical task definitions) qualification structure and skill levels prior to the design of technology. From these determinations the key criteria for the development and design of technology should be derived from.
27. User groups should consist of different status groups (shop floor workers, technical staff etc.), members of the industrial relations system. External expert should give support on both levels conceptual and design work.
28. Research and development should consider different types of user systems with respect to industrial branches, firm's structures and sizes. In particular, experiments should exemplify ways of realization of human centred technologies under conditions of small and medium sized enterprises.

B. Haywood, J. Bessant

RECOMMENDATIONS.

29. The above analysis opens up a range of research questions and issues. First is the need for much more documentation of the range of choice available under particular circumstances and the costs/benefits associated with each. This might highlight, for example, the kind of point made by Ingersoll Engineers (35), which suggests that low risk, low cost changes in production methods, such as group technology or JIT, can bring significant benefits more rapidly and reliably than high risk technological investments like FMS or CAD/CAM. For smaller firms this may represent a more viable option than full scale technology based factory renewal. Alternatively, some large manufacturers believe "the only way we will beat the Japanese is with technology", justifying extensive and sophisticated investments in technology. We would refer them to the statement of Konosuke Matsushita quoted earlier, and to problematic experiences with major technology investments such as General Motors Saturn project.
30. A second, related point, concerns the strategy for change. This may be on the basis of "islands of automation" or organisational change or quantum leaps in technology or a simultaneous organisation and technology change - or even a no technology approach. Options and consequences need to be examined more thoroughly. Here too some indication of practical experience in incremental strategies would be valuable information to collate

and organise. This could also be achieved through the type of simulation exercises conducted by the U.Ks National Economic Development Office (36) project which suggested how each level of investment could be used to fund the next.

31. Third is the need to identify and describe the different kinds of integration required. This should clarify the issues and to set them in the context of different firm size and sector. For example, we have listed above some of the areas such as functional integration, though we should discover which functions will be affected most. In the field of work organisation design, traditional Tayloristic approaches may be less than appropriate for integrated tasks and the skills required in the factory of the future. In particular, there is considerable discussion around the options for devolving power and autonomy back to the shop floor - by using skilled labour as a key integrative interface (37).
32. Fourth, analysis and research needs to be developed in several other areas; for example, a consequence of traditional patterns of organisation has been the need for long vertical hierarchies in the firm but this is likely to be challenged by integrated technologies. Similarly, traditional linkages between suppliers and users have focussed on price negotiation, yet evidence is growing of the need for radically changing this pattern. Lastly, in the field of functional integration, which areas/functions are particularly affected and how (eg, in links between design and manufacturing, or accounting and marketing).

Finally, although there is growing evidence in the literature about the problems posed by integrated technologies and the need for organisational adaptation, there is relatively little we know about how to make those changes. Input might include education and training, job design or full scale organisation development interventions. What may be needed is not so much the development of totally new methodologies, but adapting and transferring those already proven in other areas, such as, socio-technical systems design.

Burkart Sellin  
CEDEFOP

12 January 1987

New Manufacturing Systems:  
Implications for Initial and Continuing Training

Although it is not yet possible to forecast the contours of future manufacturing systems insofar as these will be influenced by various factors, our present-day knowledge already suffices to make a number of recommendations regarding the development of initial and continuing vocational training. Of course, it will be necessary to take account of the situation prevailing in each Member State concerned: some Member States are already in a very favourable position for adjusting to new developments on the strength of their existing training potential; others will have to address themselves to totally revising their vocational training policy if they intend to continue to play a major role in this field.

33. Provision for retraining or continuing training schemes for existing personnel and for the training or induction of new personnel should commence prior to the introduction of new manufacturing systems or at the latest with their installation.

This calls for a stock-taking of the existing or available training potential and the definition of the ideal situation for the new manufacturing system in the light of the type of work organization envisaged. Although manufacturers can assume responsibility for providing some of the induction or continuing training, the major part has to be covered by the company itself or by inter-company, group training centres. Without a comprehensive training effort, it is seldom

possible to exploit to the full the possibilities offered by modern manufacturing systems: sensitivity and downtimes are likely to increase, thereby cutting down productivity. A number of firms have already gone bankrupt as a result of the concomitant low return on their capital investment others have relied unduly on the manufacturers of such new systems.

34. The skilled manpower directly engaged in the manufacturing process - turners, millers, planers - are trained to work as experts in meta-cutting techniques who can master the full range of mechanical, electronic, hydraulic and sensorimotor techniques involved. In addition to carrying out straightforward servicing operations, they should be able to cope with maintenance work and also repair the system in the event of breakdown. These abilities are particularly necessary where the programming work is particularly customized. Under certain circumstances, however, such skilled work can acquire a new dimension of autonomy, quite different from the conventional concepts of piecework or hourly wage systems.
  
35. More intensive efforts should be made to train unskilled and semi-skilled workers to become skilled workers of the modern type, this presupposing new forms of combined in-company and external continuing training. New forms of alternance training linking in-company work experience with theory instruction outside the company and leading to recognized qualifications should also be developed for older workers. Temporary release for education and training purposes is of increasing advantage to both the company and the individual insofar as hitherto unused creativity and learning potentials can be harnessed for revitalizing production and work organization and the workforce can

be actively involved in shaping this process with a view to upgrading their own working conditions. Collective bargaining and corporate agreements should pay increasing attention to such training components in future.

36. A change is taking place in the corporate hierarchical structure of the core workforce in industry. There is a possibility here that the gap between the highest and lowest levels will be narrowed and that the number of intermediate levels will decline: the skilled worker will become his own shop-floor foreman, he will move away from manual, operative tasks and be more of a technician with monitoring and programming duties who organizes the manual operation of the plant and machinery. Initial vocational training has hardly taken account of this development; it still makes a rigid distinction between manual and operative training on the one hand and more advanced training requiring greater individual initiative on the other.
  
37. As initial vocational training systems oriented towards providing a training to last a lifetime are increasingly losing ground in the race with technological advance, the continuing training field is currently experiencing a renaissance which is finding expression in both the "training campaigns" and new training initiatives launched by governmental institutions and also in the increasing effort being invested in this field by private agencies and companies. Initial and continuing vocational training is once again edging closer to the corporate sphere, but this time without necessarily being company-specific in the conventional manner. On the contrary, it is becoming ever broader and ever more comprehensive, but at the same time remaining in line with company needs



in order to raise skilled workforce loyalty to corporate goals. To some extent, European firms are being influenced by the Japanese model, for in-company continuing training has long served in Japan as an important instrument in keeping the workforce with the firm and at the same time utilizing previously wasting potential.

The Taylorist/Ford process whereby skilled work has been broken down into a large number of strictly delineated sub-occupations could find itself not only stopped but even switched into reverse by the new manufacturing systems.<sup>1)</sup> However, it would be misguided to believe that this would render specialization superfluous, as only by means of specialization and consolidated know-how is it possible to create the necessary sensitivity for high-quality work and to apply the corresponding skills to other situations, fields of manufacturing and activities: a tool-maker is able to adjust more rapidly to timber or plastics processing than an industrial fitter who has no training in the basic techniques of cutting, forging and moulding. A graduated approach to training providing for basic occupational/technical training, skilled training and specialization will therefore remain an important consideration.

- 
1. This trend does not necessarily preclude the emergence of new, perhaps even more rigid forms of labour division with use being made of the greater control possibilities offered by modern manufacturing systems.

39. None of the highly developed industrial societies will be able to afford to allow up to 50% or even more of their young generation to enter working life without a skilled training. Training as a skilled worker or skilled employee to level 2 of the training structure proposed by the EC Commission as a reference framework (see Council Decision of July 1985), appears to be a minimum requirement for anyone striving for - or having to strive for - stable employment.
40. At the same time, corporate needs for continuing training and the continuing training demand forthcoming from both the employed and the unemployed will call for the establishment and consolidation of a fourth field of government-controlled and government-organized education provision alongside the existing primary, secondary and tertiary fields, i.e. continuing training provision, if the many demands placed on continuing training today are to be met satisfactorily.