

Using Comics to Destigmatize Burn-Out and Depression: An Experimental Investigation

Röhm, Alexander; Nellen, Cosima; Möhring, Michéle; Hastall, Matthias R.

Erstveröffentlichung / Primary Publication

Konferenzbeitrag / conference paper

Empfohlene Zitierung / Suggested Citation:

Röhm, A., Nellen, C., Möhring, M., & Hastall, M. R. (2022). Using Comics to Destigmatize Burn-Out and Depression: An Experimental Investigation. In J. Vogelgesang, N. Ströbele-Benschop, M. Schäfer, & D. Reifegerste (Eds.), *Gesundheitskommunikation in Zeiten der COVID-19-Pandemie* (pp. 1-17). Stuttgart: Deutsche Gesellschaft für Publizistik- und Kommunikationswissenschaft e.V. <https://doi.org/10.21241/ssoar.86031>

Nutzungsbedingungen:

Dieser Text wird unter einer CC BY Lizenz (Namensnennung) zur Verfügung gestellt. Nähere Auskünfte zu den CC-Lizenzen finden Sie hier:

<https://creativecommons.org/licenses/by/4.0/deed.de>

Terms of use:

This document is made available under a CC BY Licence (Attribution). For more information see:

<https://creativecommons.org/licenses/by/4.0>

Using Comics to Destigmatize Burn-Out and Depression: An Experimental Investigation

Alexander Röhm, Cosima Nellen, Michéle Möhring, Matthias R. Hastall

TU Dortmund University

Zusammenfassung

Comics bieten ein vielversprechendes, aber bislang kaum genutztes Potenzial für die Kommunikation von Gesundheitsinformationen. Über die Wirkung von Comics bei der Aufklärung über psychische Erkrankungen wie Depressionen oder Burnout ist wenig bekannt. Depressionen werden von Laien oft als Burnout bezeichnet, was zu einer geringeren Stigmatisierung der Betroffenen, aber auch zu einer Verharmlosung depressiver Symptome führen kann. In der vorliegenden Studie (N = 1.201) wurde untersucht, wie das Geschlecht des Fallbeispiels und zusätzliche Sachinformationen in Comics die Stigmatisierung der Rezipierenden gegenüber Betroffenen beeinflussen und welche Rolle kognitive Prozesse dabei spielen. Die Ergebnisse bestätigen die destigmatisierende Wirkung des Burnout-Labels im Vergleich zu einem Depressions-Label. Die beobachteten Effekte sind jedoch von geschlechtsspezifischen Wahrnehmungen und in gewissem Maße von kognitiven Prozessen bei der Bildung stigmatisierender Einstellungen abhängig. Implikationen für die strategische Anti-Stigma- und Gesundheitskommunikation werden diskutiert.

Keywords: Depression, Burnout, Gesundheitskommunikation, Comics, Stigma

Summary

Comics are considered a promising, but often neglected medium for health information. However, little is known about the effects of comics providing health information about mental illnesses like depression or burn-out. Depression is often labeled by laypersons as burn-out, which can lead to reduced stigmatization of affected individuals, but likewise to a trivialization of depressive symptoms. The present study (N = 1,201) examined how the depiction of mental illness labels, exemplar's sex, and additional factual information in comics influences recipients' stigma-related perceptions about affected individuals and which role cognitive processes play in this regard. Results confirm the stigma-reducing effect of the burn-out label compared to a depression label. The observed effects, however, rely on sex-specific perceptions and, to some extent, on cognitive processes for the formation of stigmatizing attitudes. Implications for strategic anti-stigma and health communication are discussed.

Keywords: Depression, Burn-out, Health Communication, Comics, Stigma

1 The Potential of Comics About Depression and Burn-out for the Destigmatization of Affected Individuals

Comics can be described as an important, but often neglected medium for education (e.g., in health-related contexts) and attitude formation (Branscum et al., 2013; Sharma & Branscum, 2009). Their advantages over solely textual information are attributed to factors such as humor and vividness as well as “the psychological and cognitive effects of embodiment and narrative, the translation of lived experiences into stories” (Dobbins, 2016, p. 35). Accordingly, comics seem to be promising for mediated contact-based anti-stigma approaches (cf. Park, 2012). Since popular comics about mental illnesses are often considered as stereotypical and stigmatizing (e.g., Goodwin & Tajjudin, 2016), there is a growing demand for graphic mental health information that are equally accurate, persuasive, educational, and stigma-sensitive (Farthing & Priego, 2016). Accuracy, in particular, is an important factor, as depression is often labeled as “burn-out” by laypersons, which is a less stigmatized condition, but can lead to inaccurate public perceptions about both mental health conditions and a trivialization of depression (Berger et al., 2012). Thus, it remains unclear (1) if both conditions (depression and burn-out) should be depicted synonymously or differently in mental health information and (2) how different characteristics of affected persons (e.g., sex) as well as factual information about both conditions that are embedded in a comic strip can contribute to education and reduced stigmatization concerning depression and burn-out.

In accordance with *exemplification theory* (Zillmann & Brosius, 2000), personifications in comics can be considered visual exemplars (c.f. King, 2016) that are perceived as representatives of their larger population. Such single-case depictions are known to affect recipients’ opinions and attitudes towards social issues like mental health problems (e.g., Röhm et al., 2022), whereas attitudes toward the single phenomenon (e.g., a person with depression) are generalized toward the whole group (e.g., persons with depression in general). In addition, factual information related to an illness (e.g., concerning symptoms, prevalence, causes) is considered to be likewise effective, and potentially destigmatizing (e.g., McGinty et al., 2015). Thus, the current study examines if visual exemplars (i.e., stick figures in a comic strip) featuring the mental illness labels “depression” or “burn-out” influence recipients’

stigma-related attitudes, illness perceptions, and behavioral intentions towards affected individuals differently. Additionally, we test whether (a) exemplar’s sex and (b) the provision of factual information moderates the proposed labeling effects on stigma-related outcomes, and (c) which roles cognitive processes (i.e., cognitive involvement and ease of cognitive access) play in this regard.

Influence and Interactions of Mental Illness Label and Exemplar’s Sex

According to the World Health Organization’s 11th revision of the *International Classification of Diseases* (ICD-11), the same set of symptoms qualifies for both depression and burn-out. However, research shows that the burn-out label in comparison to depression reduces social stigma, but also reduces intentions to seek professional help (Bahlmann et al., 2013). This can be attributed to a presumption of higher controllability for burn-out than for depression (cf. Dijkster & Koomen, 2003). Diagnoses of burn-out, which are predominately associated with work-related performance problems and stress (Bahlmann et al., 2013; Berger et al., 2012; Maslach & Leiter, 2008), lead to a non-recognition of an often underlying depression (Gilbody et al., 2012). Building on Weiner’s (1985) *theory of achievement motivation*, the stigma-reducing effect of the burn-out label, on the one hand, can be attributed to the perception of burn-out (i.e., job burn-out; Maslach & Leiter, 2008) as an indicator for *success*. A depression label, on the other hand, is predominately associated with *failure* by affected persons themselves (e.g., Yeo et al., 2017) but also in the public perception due to the higher prevalence of this severe mental illness of 13.6% among persons with a low socio-economic status compared to persons with a medium (7.6%) or high (4.6%) socio-economic status (Berger et al., 2012). Following assumptions derived from *social comparison theory* (Festinger, 1954), such perceptions should provide recipients of a comic depicting one of those mental illness labels with relevant cues for either favorable (*upward comparison*) or unfavorable (*downward comparison*) comparisons with the exemplar (cf. Locke, 2014). Thus, we assume that the success-related burn-out label decreases stigmatization as well as increases ascribed controllability and positive behavioral intentions, compared to the depression label:

Hypothesis 1: Labeling the depicted mental illness in a comic strip as burn-out in comparison to depression evokes less stigmatization, but a higher perception of

controllability and more positive behavioral intentions towards affected individuals.

Due to a higher prevalence for burn-out and depression in Germany affecting women (e.g., Hapke et al., 2013), we expect that the achievement-related effect of the mental illness label is additionally moderated by the depicted sex of the exemplar. Since men with burn-out or depression are less prevalent and therefore less visible to the public, they are likely to be more stigmatized than women with the same mental health conditions (e.g., Chatmon, 2020). Wirth and Bodenhausen (2009), for instance, assumed a different attribution of responsibility and controllability for effects they found in mental illness-sex constellations showing that males with depression decreased respondents' negative affect and increased sympathy, compared to females with depression. Other scholars (e.g., Boysen et al., 2014; Boysen, 2017), however, suggest an effect of perceived masculinity or femininity of the mental illness condition itself rather than the sex of the affected person. In the context of the present study, the success-related associations with the burn-out label are closely linked with masculine norms and role orientations (Milner et al., 2018) leading to the presumption that female exemplars with depression will elicit more stigmatization than male exemplars with depression (*femininity and failure association*). Male exemplars with burn-out, in contrast, are less stigmatized than female exemplars with burn-out (*masculinity and success association*). Thus, the following hypotheses are tested:

Hypothesis 2a: Female exemplars with depression evoke more stigmatization and ascribed controllability as well as fewer positive behavioral intentions than male exemplars with depression.

Hypothesis 2b: Male exemplars with burn-out evoke fewer stigmatization and ascribed controllability as well as more positive behavioral intentions than female exemplars with burn-out.

The Role of Factual Information and Cognitive Processes for Attitude Changes

Besides mediated or physical contact with people with mental illness, *education* using accurate factual information to counter stereotypes is also known to be highly effective for the reduction of stigmatization (e.g., Corrigan et al., 2012; Papish et al., 2013) and has also been applied to comics in the context of public health campaigns (Tekle-Haimanot et al., 2016).

Various studies have demonstrated the effectiveness of factual information in reducing stigmatization (e.g., McGinty et al., 2015), leading to the following hypothesis:

Hypothesis 3: Recipients report less stigmatization and higher ascribed controllability and positive behavioral intentions towards both depression and burn-out labels when presented with additional factual information together with the comic strip, compared to presenting no additional information.

Furthermore, we assume that the effects of a graphic medium as well as the interaction with additional factual information on stigmatization do not only materialize as direct, but also as indirect effects involving cognitive processing. Due to their imagery comics are considered to be very effective to facilitate cognitive processing of the information presented (Dobbins, 2016; Houts et al., 2006). The presentation of pictures, especially as simple representations, increases the likelihood of cognitive processing such as flow-like experiences and cognitive involvement. Based on Csikszentmihalyi's (1977) original conceptualization, *flow* can be described as the state of being fully cognitively engaged with an activity or medium due to its attention-grabbing nature and imagery. The concept shows substantial overlap with transportation and narrative engagement (cf. Appel & Richter, 2010; Green & Brock, 2000) and is synonymously defined as *ease of cognitive access* (Appel et al., 2002). Thus, we presume that the experience of flow (i.e., ease of cognitive access) influences the effect of graphic mental health information on stigma-related attitude changes.

Following the *elaboration likelihood model of persuasion* (ELM; Petty & Cacioppo, 1986) *cognitive involvement* is another key requisite for stable attitude changes on the *central route* of processing that requires a higher cognitive involvement than the *peripheral route* (Petty et al., 2002; Petty & Cacioppo, 1986). In summary, we expect that the effect of the depicted mental illness label in a comic on recipients' stigmatization towards affected individuals is influenced by recipients' cognitive involvement and ease of cognitive access, which are addressed in the following research questions:

Research Question 1: Does a comic strip about depression or burn-out affect recipients' cognitive involvement and ease of cognitive access differently?

Research Question 2: Does the presentation of factual information moderate the effect of the mental illness label on cognitive involvement and ease of cognitive access?

Research Question 3: Do cognitive involvement and ease of cognitive access mediate the effect of the mental illness label on stigmatization, controllability, and positive behavioral intentions?

Research Question 4: Does the presentation of factual information moderate the mediation of the mental illness label via cognitive involvement and ease of cognitive access on stigmatization, controllability, and positive behavioral intentions?

2 Method

Design and Procedure

In a $2 \times 2 \times 2 \times 2$ between-subjects online experiment, respondents were randomly assigned to one of 16 surveys, each of which included a comic strip about an exemplar with a mental illness. The comic strip was manipulated regarding the depicted *label of mental illness* (depression vs. burn-out), *exemplar's sex* (male vs. female), *recovery perspective* (positive vs. negative; not used in analyses due to low reliability), and *factual information* about the illness (info box vs. no info box). After the stimulus presentation, cognitive involvement and ease of cognitive access were measured as mediators, followed by stigmatizing attitudes towards affected individuals and illness perception of depression or burn-out, as well as positive behavioral intentions as dependent variables (see Table 1 for an overview). Finally, sociodemographic data was collected.

Stimulus Material

The short comic strips consisted of four frames showing an exemplar of a person with a mental illness as a stick figure (Figure 1). In the first frame, the person is introduced as either "Karl" or "Karla" (male vs. female) who has depression or burn-out. The second frame shows a sad and exhausted Karl or Karla in addition to a symptomatic description. The third and fourth frame contain information about an either positive or negative perspective regarding the exemplar's occupation and friendships which is accompanied by an either smiling (positive) or sad (negative) facial expression. Factual information about depression or burn-out including typical symptoms and

prevalence in Germany is either embedded into an info box below the comic strip or was omitted.

Manipulation Check

A previous manipulation check with $N = 40$ participants ($M = 39.00$ years; $SD = 17.75$; 50% female) confirmed the successful manipulation of the mental illness label (Krippendorff's $\alpha = .68$), the depicted sex (Krippendorff's $\alpha = .90$), and the factual information (Krippendorff's $\alpha = .60$). The interrater agreement for the recovery perspective manipulation (Krippendorff's $\alpha < .60$) must be considered insufficient and will therefore only be included into the analysis as covariate for control.

Sample

A total of $N = 1,201$ respondents ($M = 28.40$ years; $SD = 11.76$; 78.4% female) completed the survey. Respondents were recruited through German-speaking social media sites and messaging boards.

Instruments

Cognitive involvement and ease of cognitive access were assessed as mediators, personal stigmatization, controllability, and positive behavioral intentions as dependent variables (see Table 1 for detailed information).

Table 2 shows means, standard deviations, and intercorrelations of the two mediator variables and the three dependent variables. All data analyses were conducted using IBM SPSS version 26.

3 Results

In a first step, our hypotheses 1, 2a, 2b, and 3 were tested with a multivariate analyses of covariance (MANCOVA) including the three experimental manipulations as well as respondents' sex (for control) as factors and the recovery perspective manipulation as covariate (for control) on all three dependent variables. To protect subsequent univariate analyses of covariance (ANCOVAs) against type I error, only effects of the MANCOVA with $p < .05$ using Pillai's trace are reported (Field, 2018). Sidak-corrected simple effect post-hoc tests were used. Significant main effects and higher-order interactions are reported below.

Main Effects of Experimental Manipulations

A significant main effect of the mental illness label, $V = .034$, $F(3, 1182) = 13.844$, $p < .001$, emerged with respect to all three dependent variables. In line with hypothesis 1, the depression label yielded significantly more stigmatizing attitudes as well as a reduced perception of controllability and fewer positive behavioral intentions than the burn-out label (Table 3).

Main Effects of Respondents' Sex

A main effect of respondents' sex became significant with respect to all three dependent variables, $V = .017$, $F(3, 1182) = 6.849$, $p < .001$. Male respondents indicated a higher perceived controllability of mental illness and higher internalized stigmatization, but also less positive behavioral intentions towards affected individuals than female recipients (Table 4).

Higher-order Interactions of Experimental Manipulations

A mental illness label \times sex \times factual information three-way interaction, $V = .009$, $F(3, 1182) = 3.426$, $p = .017$, emerged for reported personal stigmatization towards affected individuals, $F(1, 1184) = 7.565$, $p = .006$, $\eta^2 = .006$. Figure 2 shows that a depiction of a male exemplar with depression evoked more personal stigmatization than a male exemplar with burn-out when factual information was presented. However, a depiction of a female exemplar with depression yielded more personal stigmatization than a female exemplar with burn-out when no factual information was presented. Moreover, the presentation of factual information increased reported personal stigmatization towards female exemplars with burn-out, compared to the same condition without factual information. However, these findings do not provide clear support for our hypotheses 2a, 2b, and 3, which are therefore rejected.

Conditional Indirect Effects of the Mental Illness Label on Personal Stigmatization

In a second step, the hypothesized mediated effects of the experimental manipulations via cognitive involvement and ease of cognitive access on recipients' stigma-related attitudes, as addressed in our research questions 1 to 4, were tested using Hayes' (2018) PROCESS macro (model 10). In order to further examine the observed three-way interaction effect, the following variables were included in the moderated

mediation model (Figure 3): the depicted mental illness label as predictor, recipients' reported personal stigmatization as outcome, exemplar's sex and factual information as moderators, as well as cognitive involvement and ease of cognitive access as mediators.

Unstandardized regression coefficients and levels of significance of the conditional effects of the predictor on the mediators (a paths), the effects of the mediators on the outcome (b paths), the conditional total effects of the predictor on the outcome (c paths), the conditional direct effects of the predictor on the outcome controlling for the mediators (c' paths), and the conditional indirect effects of the predictor on the outcome via one of the mediators ($a \times b$ paths) are shown in Table 5.

A small, but significant indirect effect of the mental illness label on reported personal stigmatization via ease of cognitive access emerged for the condition of a comic with a male exemplar and an info box, $b = -.02$, $SE = .01$, 95% BaCI [-0.045; -0.004]. Accordingly, a comic about burn-out, compared to depression, was perceived as easier cognitively accessible, which in turn evoked less personal stigmatization. However, there were no significant conditional indirect effects of the mental illness label on reported personal stigmatization via cognitive involvement as mediator. When controlling for both mediators, significant direct effects of the mental illness label on personal stigmatization occurred, indicating a stigma reduction by depictions of burn-out (vs. depression) for the following conditions: comics with male exemplars and no info box, comics with male exemplars and info box, as well as comics with female exemplars and no info box (Table 5).

4 Discussion

The aim of the present study was to shed light on the questions (1) if and how depression and burn-out should be depicted and treated synonymously or differently in the context of health communication and (2) how different exemplar characteristics as well as factual information that are embedded in a comic strip affect stigma-related attitude changes. Overall, the results reveal that recipients assessed depression and burn-out differently in terms of stigmatization and illness perception. Comic representations proved to be a promising medium for stigma-related attitude changes.

As presumed by our first hypothesis, comics containing

the burn-out label significantly reduced stigmatization and increased positive behavioral intentions towards affected individuals, in comparison to comics featuring the depression label. This finding is in line with previous research (Bahlmann et al., 2013). However, as derived from achievement motivation theory (Weiner, 1985), the burn-out label also increased the controllability ascribed to the mental illness, indicating a perceived higher individual responsibility for the illness, which is often associated with blame (Dijker & Koomen, 2003), less willingness to help and to seek help (Corrigan et al., 2012). This finding is consistent with observations by Bahlmann et al. (2013), which indicated that burn-out is perceived as less serious and probably treatable by the affected persons themselves. Thus, destigmatization is not necessarily an indicator for increased support, a finding that deserves further examination and underlines the need for more differentiated measures like ascribed responsibility and blame.

Concerning our hypotheses 2a and 2b regarding sex-specific interaction effects with the depicted mental illness label, no clear significant pattern emerged. Likewise, the presentation of factual information did not show destigmatizing effects in combination with the mental illness label, as presumed in hypothesis 3. Thus, both hypotheses must be rejected. The detected three-way interaction indicates a rather complex interplay of all three stimulus characteristics. The identified differences in recipients' stigmatization toward persons with depression or burn-out indicate that (a) a stigma-reducing effect of the burn-out label did only emerge in combination with factual information for male exemplars, while (b) depicted females only benefited from the burn-out label when no factual information was presented. These results are in contrast to the assumptions that were made based on previous research (cf. Boysen et al., 2014; Boysen, 2017; Wirth & Bodenhausen, 2009). Yet, the yielded effects still represent a sex-specific interaction pattern regarding the effectiveness of re-labeling approaches and educational information that should be considered in future research.

Recipients' sex, which had been included as control, also yielded significant differences in the reported stigmatization. Female recipients indicated less stigmatization and more positive behavioral intentions toward persons with depression or burn-out, compared to males, which is in line with findings from previous studies (e.g., Möhring et al., 2021). In contrast to the primarily female total sample, male recipients ascribed

more controllability to both mental illness labels, which indicates that stigmatization and controllability towards mental illness are unidimensional reactions for male recipients. The controllability ascribed to mental illness by male recipients resembles a stereotypical way of dealing with mental health problems that is characterized by a low level of seeking help (Chatmon, 2020). Thus, effects of recipients' sex, particularly male reactions to mental illness labels, need to be considered more closely in upcoming studies.

To address our four research questions, we investigated the observed three-way interaction more closely using a moderated mediation model. The mediation analysis revealed that only the combination of a comic depicting a male exemplar with burn-out and additional factual information was able to elicit a flow-like experience through ease of cognitive access and, in turn, reduce stigmatization. All other combinations failed to arouse cognitive involvement or ease of cognitive access. On the one hand, it can be presumed that, in contrast to theoretical assumptions in the present literature (e.g., Dobbins, 2016), cognitive processes played a subordinate role concerning stigma-relevant attitude changes in our study. On the other hand, it could also be possible that the stigma associated with mental health topics prevented a cognitive engagement with the comics. Regarding the importance of cognitive processing of the message content for more stable attitude changes following the ELM (Petty et al., 2002; Petty & Cacioppo, 1986), the observed effects supposedly did not endure. Hence, future research is needed to fully understand the effects and underlying mechanisms of comics that address mental illnesses as well as the role of masculine norm orientations.

Limitations

Despite the large sample, most results show rather small effect sizes that reduce generalizability (Ellis, 2010). This holds true for the mediation effect. Further investigations should consider a more powerful approach to examine the impact of each manipulation in more detail, and, in addition, should also account for possible long-term effects. The sample in this study is considerably biased with regard to the high number of almost 80% female respondents which is a general issue in online studies. Thus, the interpretability of sex-related effects and interactions is limited, highlighting the need to recruit samples with a more equal sex distribution. We did not have a dedicated control group without a stimulus, which should be included in

upcoming studies to gather further information about the effectiveness of the manipulations tested as well as the general effect of a comic strip on attitude changes. Several studies report stigma-reducing effects of treatment-related or recovery-related information in case vignettes (e.g., McGinty et al., 2015) or news articles (Röhm, 2017). Such information had originally been included in the stimulus material, but did not prove to be reliable and was therefore excluded as a factor in our analyses. Compared to the text-based stimulus material used in the other studies, the depicted comic strip was possibly too short to convey a believable outlook on the exemplar's chance for recovery. Thus, future research should employ a more persuasive and reliable way to include such information into message materials to further examine the attributed effects.

Conclusion

All in all, our findings help to shed light on the possibilities to use comics for health and anti-stigma communication. As a medium, comics can provide a simple way to depict complex health issues (Houts et al., 2006) that easily gain recipients' attention and can facilitate, to some extent, cognitive engagement with information about mental health issues. Future efforts, however, need to consider possible unintended effects of sex-typical or sex-untypical mental illness representations as well as sex-specific reactions to the depicted issues in order to facilitate an accurate knowledge acquisition and perception of mental illnesses.

5 Acknowledgement

The authors thank Laura Estner, Lena Heubach, Lydia Posmik, and Hanna Winkler for their commitment and support regarding stimulus design, pretesting, and sample recruitment.

References

Appel, M., Koch, E., Schreier, M., & Groeben, N. (2002). Aspekte des Leseerlebens: Skalenentwicklung [Assessing experiential states during reading: Scale development]. *Zeitschrift Für Medienpsychologie*, *14*(4), 149–154. <https://doi.org/10.1026//1617-6383.14.4.149>

Appel, M., & Richter, T. (2010). Transportation and need for affect in narrative persuasion: A mediated moderation model. *Media Psychology*, *13*(2), 101–135. <https://doi.org/10.1080/15213261003799847>

Bahlmann, J., Angermeyer, M. C., & Schomerus, G. (2013). „Burnout“ statt „Depression“ – eine Strategie zur Vermeidung von Stigma?. *Psychiatrische Praxis*, *40*(02), 78–82. <https://doi.org/10.1055/s-0032-1332891>

Berger, M., Schneller, C., & Maier, W. (2012). Arbeit, psychische Erkrankungen und Burn-out: Konzepte und Entwicklungen in Diagnostik, Prävention und Therapie [Work, mental disorders and burnout: concepts and developments in diagnostics, prevention and therapy]. *Der Nervenarzt*, *83*(11), 1364–1372. <https://doi.org/10.1007/s00115-012-3582-x>

Boysen, G. A. (2017). Explaining the relation between masculinity and stigma toward mental illness: The relative effects of sex, gender, and behavior. *Stigma and Health*, *2*(1), 66–79. <https://doi.org/10.1037/sah0000041>

Boysen, G. A., Ebersole, A., Casner, R., & Coston, N. (2014). Gendered mental disorders: Masculine and feminine stereotypes about mental disorders and their relation to stigma. *The Journal of Social Psychology*, *154*(6), 546–565. <https://doi.org/10.1080/00224545.2014.953028>

Branscum, P., Sharma, M., Wang, L. L., Wilson, B., & Rojas-Guyler, L. (2013). A process evaluation of a social cognitive theory-based childhood obesity prevention intervention: The comics for health program. *Health Promotion Practice*, *14*(2), 189–198. <https://doi.org/10.1177/1524839912437790>

Chatmon, B. N. (2020). Males and mental health stigma. *American Journal of Men's Health*, *14*(4), 1557988320949322. <https://doi.org/10.1177/1557988320949322>

Corrigan, P. W., Morris, S. B., Michaels, P. J., Rafacz, J. D., & Rüsch, N. (2012). Challenging the public stigma of mental illness: A meta-analysis of outcome studies. *Psychiatric Services*, *63*(10), 963. <https://doi.org/10.1176/appi.ps.201100529>

Csikszentmihalyi, M. (1977). *Beyond boredom and anxiety* (1st ed.). Jossey-Bass.

Dijker, A. J. M., & Koomen, W. (2003). Extending Weiner's attribution-emotion model of stigmatization of ill persons. *Basic and Applied Social Psychology*, *25*(1), 51–68. https://doi.org/10.1207/S15324834BASP2501_4

- Dobbins, S. (2016). Comics in public health: The sociocultural and cognitive influence of narrative on health behaviours. *Journal of Graphic Novels and Comics*, 7(1), 35–52.
<https://doi.org/10.1080/21504857.2015.1127844>
- Ellis, P. D. (2010). *The essential guide to effect sizes: Statistical power, meta-analysis, and the interpretation of research results*. Cambridge University Press.
- Evans-Lacko, S., Rose, D., Little, K., Flach, C., Rhydderch, D., Henderson, C. R., & Thornicroft, G. (2011). Development and psychometric properties of the reported and intended behaviour scale (RIBS): A stigma-related behaviour measure. *Epidemiology and Psychiatric Sciences*, 20(3), 263–271.
<https://doi.org/10.1017/S2045796011000308>
- Farthing, A., & Priego, E. (2016). ‘Graphic Medicine’ as a mental health information resource: Insights from comics producers. *The Comics Grid: Journal of Comics Scholarship*, 6(1). <https://doi.org/10.16995/cg.74>
- Festinger, L. (1954). A theory of social comparison processes. *Human Relations*, 7(2), 117–140.
<https://doi.org/10.1177/001872675400700202>
- Field, A. P. (2018). *Discovering statistics using IBM SPSS statistics* (5th ed.). Sage.
- Gilbody, S., Bower, P., & Rick, J. (2012). Better care for depression in the workplace: Integrating occupational and mental health services. *The British Journal of Psychiatry*, 200(6), 442–443.
<https://doi.org/10.1192/bjp.bp.111.103598>
- Goodwin, J., & Tajjudin, I. (2016). “What do you think I am? Crazy?”: The Joker and stigmatizing representations of mental ill-health. *The Journal of Popular Culture*, 49(2), 385–402.
<https://doi.org/10.1111/jpcu.12402>
- Green, M. C., & Brock, T. C. (2000). The role of transportation in the persuasiveness of public narratives. *Journal of Personality and Social Psychology*, 79(5), 701–721.
<https://doi.org/10.1037/0022-3514.79.5.701>
- Griffiths, K. M., Christensen, H., Jorm, A. F., Evans, K., & Groves, C. (2004). Effect of web-based depression literacy and cognitive-behavioural therapy interventions on stigmatising attitudes to depression: Randomised controlled trial. *The British Journal of Psychiatry*, 185, 342–349.
<https://doi.org/10.1192/bjp.185.4.342>
- Hapke, U., Maske, U. E., Scheidt-Nave, C., Bode, L., Schlack, R., & Busch, M. A. (2013). Chronischer Stress bei Erwachsenen in Deutschland: Ergebnisse der Studie zur Gesundheit Erwachsener in Deutschland (DEGS1) [Chronic stress among adults in Germany: Results of the German Health Interview and Examination Survey for Adults (DEGS1)]. *Bundesgesundheitsblatt*, 56(5-6), 749–754.
<https://doi.org/10.1007/s00103-013-1690-9>
- Hayes, A. F. (2018). *Introduction to mediation, moderation, and conditional process analysis: A regression-based approach* (2nd ed.). The Guilford Press.
- Houts, P. S., Doak, C. C., Doak, L. G., & Loscalzo, M. J. (2006). The role of pictures in improving health communication: A review of research on attention, comprehension, recall, and adherence. *Patient Education and Counseling*, 61(2), 173–190.
<https://doi.org/10.1016/j.pec.2005.05.004>
- King, A. J. (2016). Visual exemplification and skin cancer: The utility of exemplars in promoting skin self-exams and atypical nevi identification. *Journal of Health Communication*, 21(7), 826–836.
<https://doi.org/10.1080/10810730.2016.1177143>
- Locke, K. D. (2014). Agency and communion in social comparisons. In Z. Krizan & F. X. Gibbons (Eds.), *Communal functions of social comparison* (pp. 11–38). Cambridge University Press.
- Maslach, C., & Leiter, M. P. (2008). Early predictors of job burnout and engagement. *The Journal of Applied Psychology*, 93(3), 498–512.
<https://doi.org/10.1037/0021-9010.93.3.498>
- McGinty, E. E., Goldman, H. H., Pescosolido, B., & Barry, C. L. (2015). Portraying mental illness and drug addiction as treatable health conditions: Effects of a randomized experiment on stigma and discrimination. *Social Science & Medicine*, 126, 73–85.
<https://doi.org/10.1016/j.socscimed.2014.12.010>
- Milner, A., Kavanagh, A., King, T., & Currier, D. (2018). The influence of masculine norms and occupational factors on mental health: Evidence from the baseline of the Australian longitudinal study on male health. *American Journal of Men’s Health*, 12(4),

- 696–705. <https://doi.org/10.1177/1557988317752607>
- Möhring, M., Krick, N. K., & Ditze, A. (2021). The influence of social support and characteristics of the stigmatisers on stigmatising attitudes towards people with mental illness. *European Journal of Health Communication, 2*(2), 66–96. <https://doi.org/10.47368/ejhc.2021.204>
- Moss-Morris, R., Weinman, J., Petrie, K., Horne, R., Cameron, L., & Buick, D. (2002). The Revised Illness Perception Questionnaire (IPQ-R). *Psychology & Health, 17*(1), 1–16. <https://doi.org/10.1080/08870440290001494>
- Papish, A., Kassam, A., Modgill, G., Vaz, G., Zanussi, L., & Patten, S. B. (2013). Reducing the stigma of mental illness in undergraduate medical education: A randomized controlled trial. *BMC Medical Education, 13*(1), 141. <https://doi.org/10.1186/1472-6920-13-141>
- Park, S.-Y. (2012). Mediated intergroup contact: Concept explication, synthesis, and application. *Mass Communication and Society, 15*(1), 136–159. <https://doi.org/10.1080/15205436.2011.558804>
- Petty, R. E., & Cacioppo, J. T. (1986). *Communication and persuasion: Central and peripheral routes to attitude change*. Springer.
- Petty, R. E., Priester, J. R., & Brinol, P. (2002). Mass media attitude change: Implications of the elaboration likelihood model of persuasion. In J. Bryant & D. Zillmann (Eds.), *Media effects: Advances in theory and research* (2nd ed., pp. 155–198). Lawrence Erlbaum Associates.
- Röhm, A. (2017). *Stigmatisierung und Entstigmatisierung von Menschen mit Behinderungen: Einfluss unterschiedlicher medialer Darstellungen auf Einstellungen und Handlungsintentionen* [Stigmatization and destigmatization of people with disabilities: Influence of different media representations on attitudes and behavioral intentions] [Dissertation], TU Dortmund University. <https://doi.org/10.17877/DE290R-18180>
- Röhm, A., Möhring, M., Nellen, C., Finzi, J. A., & Hastall, M. R. (2022). The influence of moral values on news readers' attitudes toward persons with a substance addiction. *Stigma and Health, 7*(1), 45–53. <https://doi.org/10.1037/sah0000318>
- Sharma, M., & Branscum, P. (2009). Comic books an untapped medium for health promotion. *American Journal of Health Studies, 24*(4), 430–439.
- Tekle-Haimanot, R., Pierre-Marie, P., Daniel, G., Worku, D. K., Belay, H. D., & Gebrewold, M. A. (2016). Impact of an educational comic book on epilepsy-related knowledge, awareness, and attitudes among school children in Ethiopia. *Epilepsy & Behavior, 61*, 218–223. <https://doi.org/10.1016/j.yebeh.2016.05.002>
- Weiner, B. (1985). An attributional theory of achievement motivation and emotion. *Psychological Review, 92*(4), 548–573. <https://doi.org/10.1037/0033-295X.92.4.548>
- Wirth, J. H., & Bodenhausen, G. V. (2009). The role of gender in mental-illness stigma: A national experiment. *Psychological Science, 20*(2), 169–173. <https://doi.org/10.1111/j.1467-9280.2009.02282.x>
- Yeo, S.-N., Zainal, H., Tang, C. S., Tong, E. M., Ho, C. S., & Ho, R. C. (2017). Success/failure condition influences attribution of control, negative affect, and shame among patients with depression in Singapore. *BMC Psychiatry, 17*(1), 285. <https://doi.org/10.1186/s12888-017-1451-7>
- Zillmann, D., & Brosius, H.-B. (2000). *Exemplification in communication: The influence of case reports on the perception of issues*. Lawrence Erlbaum Associates.

Table 1
Overview of the Instruments Used in the Present Study (item example and scaling translated)

Variable	Source	Item Example	Number		Cronbach's
			of Items	Item Scaling	
<i>Mediator Variables</i>					
Cognitive Involvement	Appel et al. (2002)	The comic kept me very cognitively engaged.	5	7-point Likert scale (0 = "does not apply at all"; 6 = "does fully apply")	.71
Ease of Cognitive Access	Appel et al. (2002)	The comic read extremely smoothly.	5	7-point Likert scale (0 = "does not apply at all"; 6 = "does fully apply")	.74
<i>Dependent Variables</i>					
Personal Stigmatization	Griffiths et al. (2004)	Depression/Burn-out is a sign of personal weakness.	9	5-point Likert scale (0 = "do not agree at all"; 4 = "fully agree")	.70
Controllability	Moss-Morris et al. (2002)	The progression of depression/burn-out depends on oneself.	7	5-point Likert scale (0 = "completely wrong"; 4 = "completely right")	.81
Positive Behavioral Intentions	Röhm (2017), based on Evans-Lacko et al. (2011)	I would accept a person with schizophrenia in my neighborhood.	4	5-point Likert scale (0 = "do not agree at all"; 4 = "fully agree")	.80

Table 2

Means, Standard Deviations, and Intercorrelations of the two Mediator Variables and the three Dependent Variables

		<i>M</i>	<i>SD</i>	(2)	(3)	(4)	(5)
<i>Mediator Variables</i>							
(1)	Cognitive Involvement	2.61	1.04	.22**	-.15**	-.04	.25**
(2)	Ease of Cognitive Access	4.53	.84		-.19**	.02	.23**
<i>Dependent Variables</i>							
(3)	Personal Stigmatization	.83	.56			.12**	-.43**
(4)	Controllability	2.78	.67				-.04
(5)	Positive Behavioral Intentions	3.13	.77				

Note. ** $p < .01$

Table 3

Estimated Marginal Means, Standard Errors, *F*-Values, Degrees of Freedom, Level of Significance and Effect Sizes of the Main Effects of the Mental Illness Label on all Dependent Variables

Dependent Variable	Depression		Burn-out		<i>F</i>	<i>df</i>	<i>p</i>	η_p^2
	<i>M</i>	<i>SE</i>	<i>M</i>	<i>SE</i>				
Personal Stigmatization	.94	.03	.81	.03	12.267	1184	< .001	.010
Controllability	2.70	.03	2.92	.03	22.476	1184	< .001	.019
Positive Behavioral Intentions	3.03	.04	3.16	.04	5.839	1184	= .016	.005

Note. Sidak-corrected estimated marginal means of the ANCOVAs.

Table 4

Estimated Marginal Means, Standard Errors, F-Values, Degrees of Freedom, Level of Significance and Effect Sizes of the Main Effects of Respondents' Sex on all Dependent Variables

Dependent Variable	Female		Male		F	df	p	η_p^2
	Respondents		Respondents					
	M	SE	M	SE				
Personal Stigmatization	.79	.02	.96	.04	17.302	1184	< .001	.014
Controllability	2.76	.02	2.87	.04	5.234	1184	= .022	.004
Positive Behavioral Intentions	3.16	.03	3.03	.05	5.360	1184	= .021	.005

Note. Sidak-corrected estimated marginal means of the ANCOVAs.

Table 5

Cognitive Involvement and Ease of Cognitive Access as Conditional Mediators of the Effect of the Mental Illness Label on Personal Stigmatization Moderated by Exemplar's Sex and Factual Information

Predictor		Mental Illness Label (0 = Depression / 1 = Burn-out)							
Outcome		Personal Stigmatization							
Mediator		Cognitive Involvement				Ease of Cognitive Access			
Paths		<i>c</i>	<i>c'</i>	<i>a</i> ₁	<i>b</i> ₁	<i>a</i> ₁ × <i>b</i> ₁	<i>a</i> ₂	<i>b</i> ₂	<i>a</i> ₂ × <i>b</i> ₂
Conditions of the Moderators									
Male Exemplar	No Info Box	-.24***	-.23***	.13	-.06***	-.01	.03	-.11***	-.00
Male Exemplar	Info Box	-.14**	-.11*	.15	-.06***	-.01	.20*	-.11***	-.02*
Female Exemplar	No Info Box	-.16**	-.17**	-.01	-.06***	.00	-.10	-.11***	.01
Female Exemplar	Info Box	-.07	-.06	.01	-.06***	-.00	.08	-.11***	-.01

Note. Unstandardized regression coefficients for the effects of the moderated mediation of the mental illness label as dichotomous predictor (0 = Depression / 1 = Burn-out) on personal stigmatization as outcome. Paths: *a* = conditional effect of the predictor on mediator; *b* = effect of mediator on outcome; *c* = conditional total effect of predictor on outcome; *c'* = conditional direct effect of predictor on outcome; *a* × *b* = conditional indirect effect of predictor on outcome via mediator. Significance of the conditional indirect effect is indicated by a 10,000 bootstraps 95% confidence interval not containing zero. *** *p* < .001; ** *p* < .01; * *p* < .05.

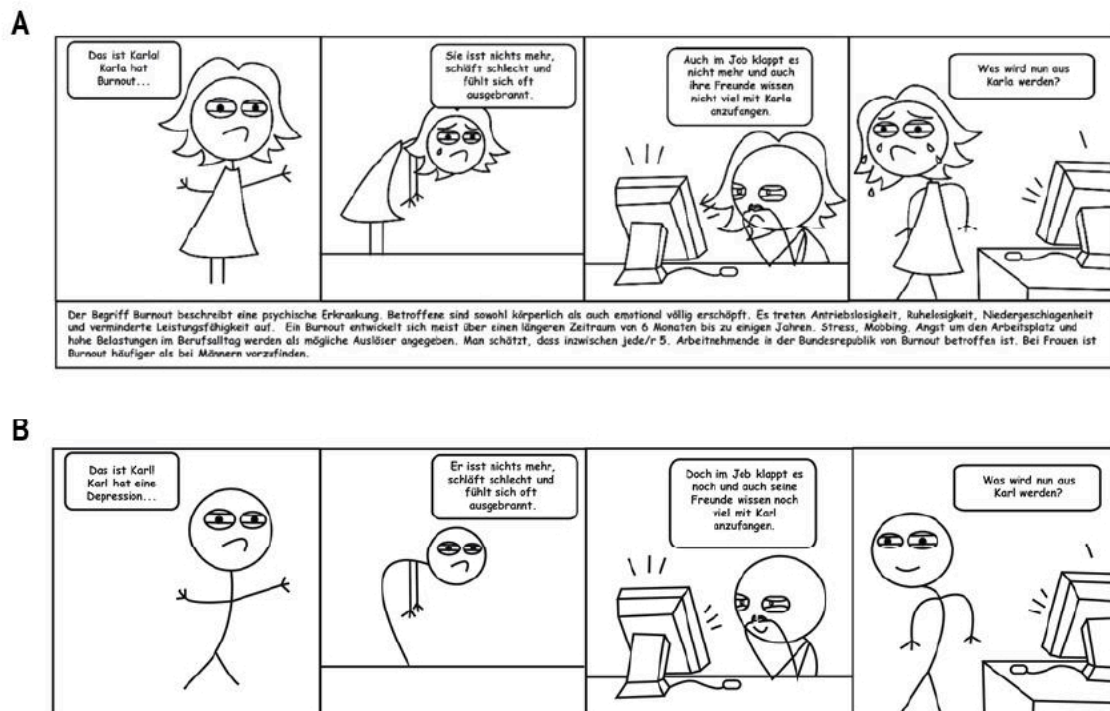

Figure 1. Example of Stimulus Material.

Note. Panel A: mental illness label: burn-out; exemplar's sex: female; recovery-perspective: negative; factual information: info box. Panel B: mental illness label: depression; exemplar's sex: male; recovery-perspective: positive; factual information: no info box.

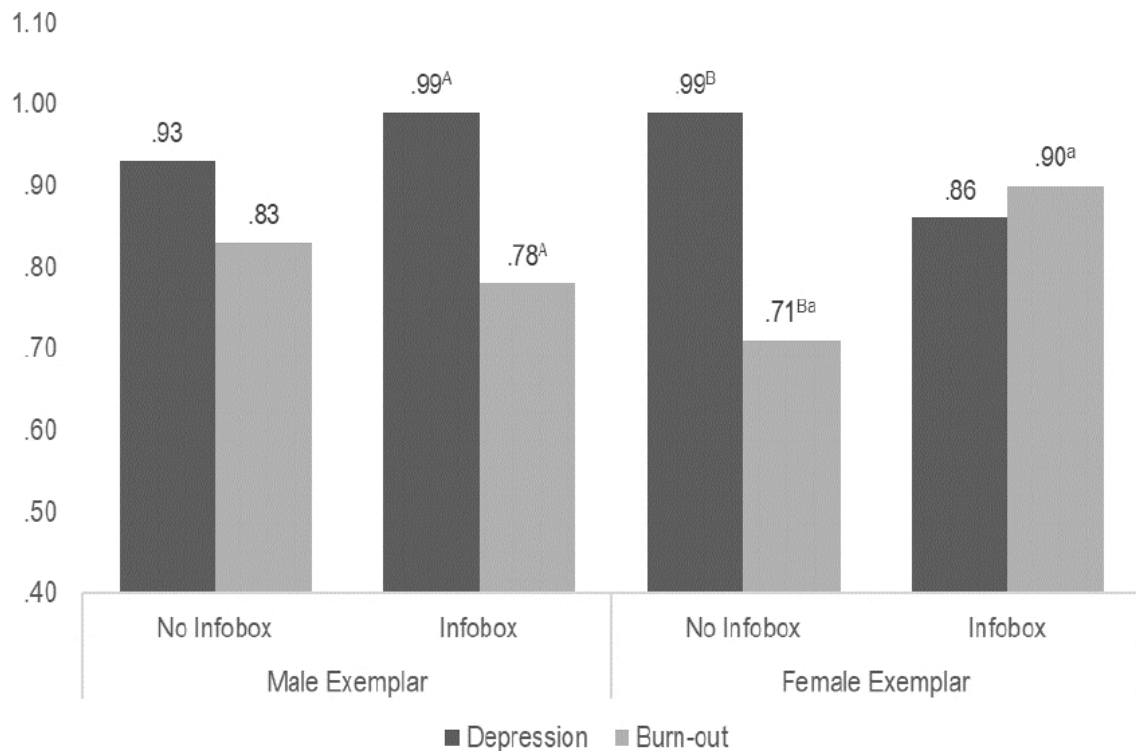

Figure 2. Estimated Marginal Means of the Mental Illness Label × Exemplar's Sex × Factual Information Three-way Interaction on Reported Personal Stigmatization.

Note. Means sharing the same upper case letter indicate significant mean differences between the mental illness label with $p < .01$, while means sharing the same lower case letter indicate significant mean differences between the presentation of factual information with $p < .05$ (Sidak-corrected simple effect post-hoc comparisons).

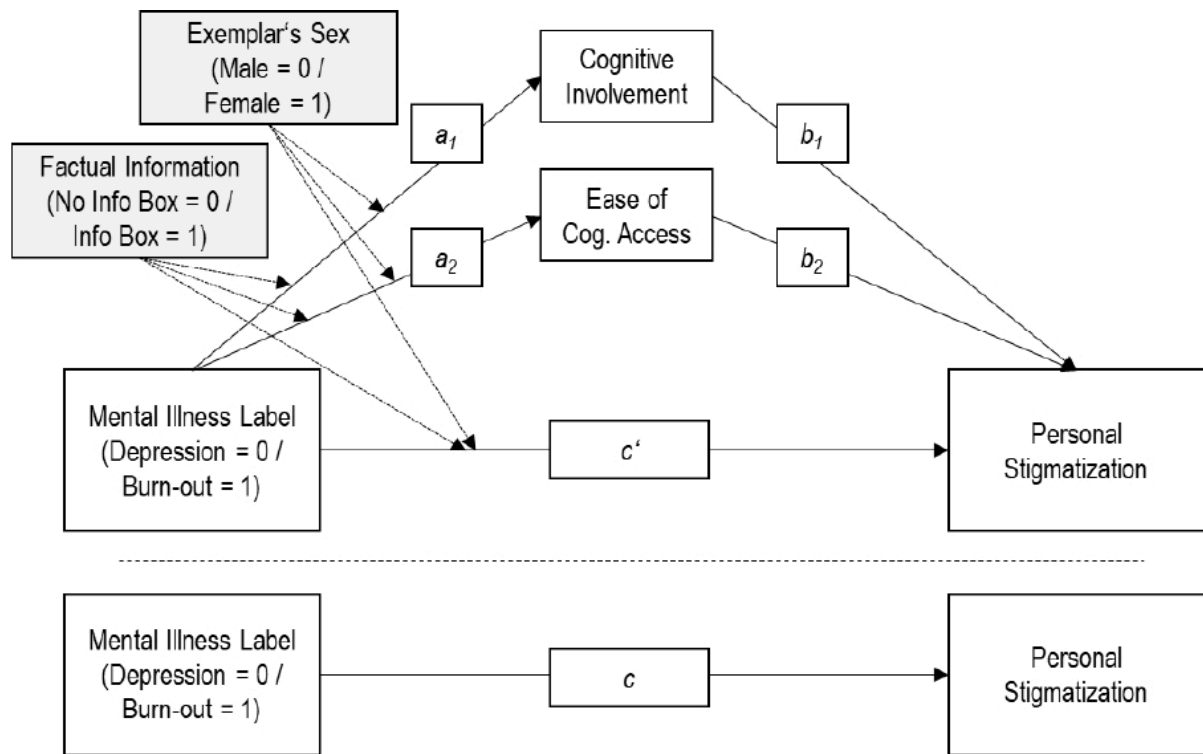

Figure 3. Conceptual Model (Model 10; Hayes, 2018) of the Moderated Mediation of the Mental Illness Label as Predictor on Personal Stigmatization as Outcome via Cognitive Involvement and Ease of Cognitive Access as Mediators.

Note. Paths: a = conditional effect of the predictor on mediator; b = effect of mediator on outcome; c = conditional total effect of predictor on outcome; c' = conditional direct effect of predictor on outcome; $a \times b$ = conditional indirect effect of predictor on outcome via mediator.