

Psychological trauma of rapid social transformations: Korea's economic crisis and Hong Kong after the reunification

Kim, Jungsik; Hung Ng, Sik; Kim, Jihyun

Veröffentlichungsversion / Published Version

Zeitschriftenartikel / journal article

Zur Verfügung gestellt in Kooperation mit / provided in cooperation with:

GESIS - Leibniz-Institut für Sozialwissenschaften

Empfohlene Zitierung / Suggested Citation:

Kim, J., Hung Ng, S., & Kim, J. (2010). Psychological trauma of rapid social transformations: Korea's economic crisis and Hong Kong after the reunification. *Historical Social Research*, 35(2), 120-150. <https://doi.org/10.12759/hsr.35.2010.2.120-150>

Nutzungsbedingungen:

Dieser Text wird unter einer CC BY Lizenz (Namensnennung) zur Verfügung gestellt. Nähere Auskünfte zu den CC-Lizenzen finden Sie hier:

<https://creativecommons.org/licenses/by/4.0/deed.de>

Terms of use:

This document is made available under a CC BY Licence (Attribution). For more information see:

<https://creativecommons.org/licenses/by/4.0>

Psychological Trauma of Rapid Social Transformations: Korea's Economic Crisis and Hong Kong after the Reunification

Jungsik Kim, Sik Hung Ng & Jihyun Kim *

Abstract: »*Psychologisches Trauma rascher sozialer Transformationen: Koreanische Wirtschaftskrise und Hong Kong nach der Wiedervereinigung*«. This article discusses the role of people's subjective evaluations in the psychological impact of significant social changes based on two studies: one in Korea after the economic crisis in 1997 and the other in Hong Kong after the reunification with China in 1997. In the series of studies, the relations among people's evaluation of social changes (pace and scope) in major social areas, the availability of coping resources, and psychological well-being were analyzed. Two studies commonly revealed that people's subjective evaluations mediated the relationship between social changes and psychological well-being. Based on the results, the authors claim the benefits of utilizing the subjective evaluation to study significant social changes.

Keywords: Social Change, Subjective Evaluation, Social Transformation, Psychological Well-Being.

As Hegel, the philosopher, once noted that everything changes and change itself is the only thing that does not change, change is vital to and characteristic of everything in the human world. As an organic entity, society is constantly changing due to many different forces (e.g., war, transportation, communication, economic exchange, etc.). In particular, today's pace of change is incomparable: Sztompka (2000) named it "The Century of Change." Due to rapid development in communication and media technology, the world is becoming a smaller and interconnected place. Hence, abrupt social changes such as the wars in the Middle East and the economic crisis in Asia were globally influential (Albrow, 1996; Hermans & Kempen, 1998; Marsella, 1998). Because social change is unavoidable in any society, many scholars in different areas,

* Address all communications to: Jungsik Kim, Associate Professor, College of Business Administration at Kwangwoon University, Seoul, Korea; e-mail: kim.jungsik@kw.ac.kr.

Sik Hung Ng, Professor, Department of Applied Social Studies at City University of Hong Kong, China; e-mail: sikhung.ng@cityu.edu.hk.

Jihyun Kim, Assistant Professor, College of Business Administration at Kwangwoon University; e-mail: jihyunk@kw.ac.kr.

Note: Parts of the results in the Korea Study reported in this article were published in *Journal of Applied Social Psychology*, 2008, 38, 11, 2821-2858.

including psychology and sociology, have studied the psychological consequences of rapid social transformation through various approaches.

One of the important approaches suggests viewing the consequences of social change as interactive outcomes that societal level changes are manifested at individual level. A number of psychologists and sociologists employ this alternative view to understand the individual level psychological processes that link the challenges on the societal level to individual reactions and long-term outcomes of psychosocial adaptation (Pinquart & Silbereisen, 2004; Pinquart, Silbereisen, & Körner, 2009; Tomasik & Silbereisen, 2009). In other words, they assert that social change manifests itself in individually perceived “situational imperatives”, “appraisals”, or “demands” that individuals need to become accustomed to (Elder, 1985; Pinquart & Silbereisen, 2004; Silbereisen et al., 2006).

Sztompka (2000) coined the term “Cultural Trauma” to describe the impact of sudden social event in comparison with “trauma”, the medical term that denotes mental and physical damage caused by a sudden, abrupt, and extreme stressful life event. Cultural trauma occurs when the normative and cognitive context of human life and social actions lose its homogeneity, coherence, and stability. This social phenomenon is called the state of cultural disorientation, and such context may include revolution, radical economic change, collapse of the financial market, political upheaval, etc. Central point of this idea is the view that the individuals are agents. Thus, the change per se is important but what is more important is the individuals’ evaluation of social change. This view proposes the idea that social change can be traumatic to people as it is subjectively experienced without necessarily affecting the individuals’ actual, concrete lives.

Based on such perspective, this article reports two studies conducted in two countries: Korea and Hong Kong which recently experienced major social transformations. The studies reported here are important in two aspects: it focuses on a micro level approach by concentrating on individuals’ subjective evaluation of social changes and it also adopts the Transactional Theory of Stress to provide a theoretical framework.

Previous studies

While social changes occur at a macro level, the influence of social changes is both social as well as personal. Many aspects of people’s lives are influenced by social changes (psychological well-being, child development, family life etc.). Among them, the question of how social change is related to psychological well-being has caught the attention of many social theorists regardless of their discipline (Conger & Elder, 1994; Durkheim, 1893, 1997; Elder, 1999; Lauer, 1991; Noack & Boehnke, 1997; Pinquart & Silbereisen, 2004; Pinquart, Silbereisen, & Juang, 2004). Especially around the 1990’s, abundant studies

focused on rapid social transformations in the former USSR and in the former Eastern Bloc countries. These studies, although conducted in various academic disciplines, concurred that social change was related to major indicators of psychological well-being, such as suicide, depression, or mental hospital admission rate (Adwin & Revenson, 1986; Banks & Ullah, 1988; Barteley, 1987; Forkel & Silbereisen, 2001; Schroeder, 1997; Schwefel, Svensson, & Zollner, 1987).

Theoretical model: Relationship between social change and psychological well-being

Regarding the relationship between social change and psychological well-being, previous studies are divided into two opposite positions. The first regards social change as a negative phenomenon viewing that social change generates negative outcomes. The most well-known theory was proposed by Durkheim (1997) who viewed that social changes result in 'anomie,' i.e. the state of an absence of norms and social-cultural integration, which negatively affects well-being. Hegelian and Marxian dialectic also concur with this view and proclaimed that social change brings about social costs. This position was widely supported in empirical studies that focused on economic changes, such as recession and unemployment, (Adwin & Revenson, 1986; Dooley & Catalano, 1980; Elder, 1999) and political and social transformations in Germany (Schroeder, 1997), Russia (Balakrishnan, 1993; Sloutsky & Searle-White, 1993), and Poland (Morris, 1998).

However, there is also a noticeable argument that asserts social change is positively related to well-being. In sociology the idea of progress was once dominantly associated with social change. Social change was viewed to be synonymous with betterment, improvement, and amelioration of human conditions. Social change was equated with such concepts as evolution, growth, and development (Sztompka, 2000). This view proposes that social change may provide the individuals with hope, excitement, and other positive opportunities to develop useful life skills and achieve self-actualization (Gersten, Langner, Eisenberg, & Orzeck, 1974; Wheaton, 1994; Veno & Thomas, 1980). For example, Elder's (1999) longitudinal studies illustrated that male adolescents who grew up during the Great Depression in the U.S. developed higher levels of adaptability and independence than cohorts who lived in more economically stable periods. By starting to work at an early age to support their families, they were provided with the opportunity to learn the adults' roles early. Similarly, in East Germany after the unification, some positive consequences were reported: the prevalence of mental disorders declined among the young due to many new opportunities that were provided to them by the unification (Ihle et al., 2001) and family cohesion was increased in the case of parental unemployment (Noack, Hofer, Kracke, & Klein-Allermann, 1995).

The review of previous studies points out the heterogeneity of psychological impact of social change (see Pinguart & Sibereisen, 2004 for review) and suggests that the relationship between social change and psychological well-being is still unclear and demands more empirical studies at both macro and micro levels.

To integrate contrasting views on social change, we adopted Lazarus and Folkman's (1984) Transactional Theory of Stress. The theory states that stress is an encounter with an environment that is appraised by the individual as taxing his or her resources and endangering his or her well-being. According to this theory, any life or social event can be potentially stressful, but whether or not it really affects psychological and physical health is a function of people's cognitive appraisal of the potentially stressful event and the availability of coping resources. If people judge that either the event is not threatening or they have the necessary resources to offset the threat, stress will not occur. Yet, if people judge that they lack adequate resources, the event will be appraised as threatening and result in deterioration of mental or physical health (Lazarus & Folkman, 1984).

Similarly, social change is an encounter with a large-scale social event that brings alterations in broad life domains and requires people's adaptations at various levels (Crockett & Silbereisen, 2000; Ihle, et al., 2001; Noack, Kracke, Wild, & Hofer, 2001). For example, during the economic crisis in Korea in 1997, the alteration in life was not limited to macro level changes such as the increase of unemployment rate, but also included psychological and cultural changes such as work values. While the main industry in Korea moved onto high-tech industry, a highly individualistic and competitive work ethic began to emerge and quickly replaced the traditional work ethics based on a collective hierarchy and group goal achievement (Yoo, 2000). During this transition, people with adequate resources adapted to the social change successfully. They acquired new knowledge and skills through job training to find better paying jobs. Thus, the changing work environment was an opportunity for them for a better life (Ihle et al., 2001). People with limited resources on the other hand, for example, workers with minimum wage jobs, were easily alienated from job training and faced the same challenge with much more difficulties.

In sum, the challenges from and coping with social change is similar to the typical stress coping process and the Transactional Theory of Stress provides a good theoretical tool to understand the relationship between social change and psychological well-being. Elder and Caspi (1990) also proposed a similar view in the Control Cycle Theory to explain the impact of abrupt social change on adolescents' development, and a similar study was reported by Pinguart et al. (2004). Thus, the present study may not be the first to adopt an integrated stress theory to understanding the psychological impact of social change but it is an empirical effort to examine its theoretical excellence.

Methodological issue: Subjective experience of social change

Previous studies on social change were limited to the analysis of macro level variables (Trommsdorff, 2000). For example, economic recession, political transformation, and unemployment were often used as variables to operationally measure abrupt social change (Noack, Kracke, Wild & Hofer, 2001). As a result, how people subjectively perceive social change and its relation to psychological well-being has been neglected in most researches (Noack, Kracke, Wild, & Hofer, 2001).

However, subjective experience of social change can be as important as the actual social change for the following reasons. People interpret a certain social change, using their own criteria and judgment, and decide whether or not the social change is actually influencing their life in a more objective form. In general, psychology has a long history of focusing on the importance of subjective experiences in human behaviors. Gestalt theory (Lewin, 1935) views that human beings live in their subjective psychological field and a crucial factor to understanding the individual's experience lies in one's own interpretation. Therefore, we must focus on the person's own subjective experiences of the social world, not on objective analysis. Thus, individuals may exhibit very different cognitive and emotional reactions to seemingly similar stressful events (Lazarus & Folkman, 1984).

Similarly, the individual experience of social change is also subjective in that people tend to respond purposefully to a changing environment by selectively perceiving events and attributing meaning to these events. Scholars point out that only the social changes meaningful to an individual's subjective psychological space may have an important influence on the individual's mental health (Doerfel-Baasen & Rauh, 2001; Kameoka & Marsella, 1999). This view is well formulated in Sztompka's (2000) "Cultural Trauma Theory". It is stated that people usually experience the state of trauma from the actual occurrence of a significant social event, but "trauma" may also arise when people subjectively interpret a disturbing social condition as potentially traumatizing. Cultural trauma often occurs when people experience rapid, substantial social transformation. Cultural trauma results in a state so-called 'cultural disorientation.' Cultural disorientation appears when sudden, unexpected, and wide-ranging novelty of unaccustomed way of life, emerging due to radically changed technological, economic, or political condition. Then, people find out that the induced new patterns of actions clash with the old traditional culture. Disorientation, it itself, does not necessarily turn into cultural traumas. A trauma occurs only when such maladjustment, tensions, and clashes are perceived and experienced as problems, thereby troubling the individuals. Thus, individuals' role in interpreting social change is important. If people define situations as real, they are real in their consequences (Merton, 1996). Thus,

there may be traumas that are not rooted in any real traumatizing events but only in the widespread evaluations and imaginations of such events. Sztompka (2000) mentions that “if enough people believe in an imminent invasion from Mars, widespread panic will result.” Therefore, in the time of social change, not all members of society experience the effects of social change at the same time, to the same degree, or in the same way. Even in times of rapid social change, only some people actually experience such macro level changes as an event that may affect their individual lives. Even when people are objectively affected by certain changes, they need not necessarily be aware of the changes, or of any changes in their own beliefs and behaviors (Trommsdorff, 2000).

Reviewed literature suggests that people may develop anxiety, depression, and worry because they view societal changes too rapidly. Specifically, if a person is keenly aware of a social event, the person may be more vulnerable to the possible negative consequences of certain significant changes compared to others who are less aware of such changes. The rapid development of communication and media technology today seems to enable people to gain prompt knowledge on changes occurring around the world, which may enormously increase their awareness of social changes indirectly but just as vividly as actual changes. Therefore, an increasing number of scholars have recently focused on the evaluation of social change as one way to study social change and its consequence on psychological well-being (Noack, Kracke, Wild, & Hofer, 2001; Pinquart & Silbereisen, 2004; Trommsdorff, 2000).

Two Studies

Considering the importance of social change as subjective experience, studies have been conducted in two countries, Korea and Hong Kong, that experienced significant, large scaled, and abrupt social changes while focusing on individuals’ subjective experiences. Both studies used the Transactional Theory of Stress as the theoretical model to explain the influences of perceived social changes on psychological well-being.

The theoretical model of the two studies is presented in Figure 1. In the model, it is conceptualized that the evaluation of social change may have two aspects: pace and scope. Pace of change was viewed as a critical factor that could bring negative consequences to mental and physical health (Sztompka, 2000, Toffler, 1980), both at theoretical level and at empirical level (Lauer & Lauer, 1976), in many studies such as recession and unemployment in Europe and the U.S. (Adwin & Revenson, 1986; Banks & Ullah, 1988; Bartley, 1987; Dooley & Catalano, 1980; Elder, 1999; Schwefel, Svensson, & Zollner, 1987), and political and social transformations in Germany (Schroeder, 1997). The scope of social change was defined by how broadly social change influences people’s life (Sztompka, 2000). It proposes that both the pace and the scope of social change would potentially increase the negative evaluation of social

change. Thus, it was predicted that the pace of social change will be related to the negative evaluation of social change (Path A). Since the concept of perceived scope of social change is newly proposed in this study, there is currently no empirical research available on how differently the extent of social change may affect the psychological well-being. Yet, it was predicted that the social changes occurring in broad social areas would also burden people more than the social changes occurring in limited areas of society (Path B).

In the proposed model, the key factor is the evaluation of social change. Applying the Transactional Theory of Stress, social change is potentially a stressor but the actual influence of social change on psychological well-being will be determined by people's appraisal of social change and the availability of perceived coping resources. Thus, the evaluation of social change is proposed as the key mediating variable connecting three types of latent variables, which are evaluations of social change (pace and scope), coping resources (personal and social) and psychological well-being (well-being and ill-being). In other words, evaluations of social change lead people to judge social change as potentially negative, as predicted by Path A and B, but the final impact on psychological well-being will be determined by the reflection of the availability of coping resources, especially personal resources (Path C).

In the model, the mediation effect of coping resources proposes that social resources be expressed through personal resources. According to Symbolic Interaction Theory (Cooley, 1902; Mead, 1934), an individual defines one's sense of self using feedbacks from significant others in his or her social environment. By internalizing the positive evaluative judgments of others in various settings, individuals can define by themselves, positively or negatively. As a result, individuals' self-worth increases by rendering the support, understanding, and positive regard of others (Cutrona & Troutman, 1986; Harter, 1986; Harter, 1998; Major et. al., 1990; Newcomb & Keefe, 1997; Rosenberg, 1985; Sarason, Saraon, & Pierce, 1994; Salzman & Holahan, 2002). Individuals who have more emotional and psychological support can attempt to accomplish goals with less fear of failure, and therefore have more opportunities to develop mastery experience compared to those with less social support (Bandura, 1997). Consequently, the mediation model of coping resources predicts that social resources bolster personal resources (Path D).

Psychological well-being is conceptualized through two latent variables: well-being and ill-being to the recommendation of the dual factor model of psychological well-being (Lawton, Moss, Kleban, & Glicksman, 1991; Meehan, 1999). Hence, the hypothesized model postulates that the evaluation of social change is separately related to well-being (Path E) and ill-being (Path F).

Figure 1: Theoretical Model

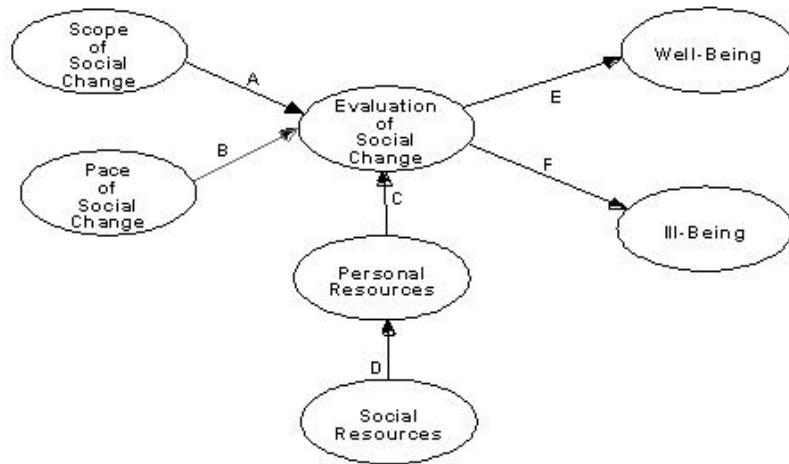

Korea Study

The first study (Kim, 2008) focuses on social change in Korea. Korea was hit with economic crisis in 1997. While many Asian countries suffered from the same crisis, the economic crisis was particularly critical to the Korea society. The GNI (Gross National Income) in 1998, dropped from \$ 11,380 to \$6,823, which was equivalent to that of 1991, representing a 40 % loss in one year. The unemployment rate, which had been as low as 2 % for the previous 10 years, skyrocketed to 8.1 % (Chang, 1999). The poverty population doubled in 1998, but did not decrease until 2000 (Kim & Park, 2000). Economic recession during this period was especially traumatic since the Korean people had been experiencing continued economic growth for four decades since 1950 and never suffered from any sort of recession during this time.

The most traumatic result of economic hardship was family disorganization. Due to economic hardship and difficulty in getting a job, young couples avoided pregnancy resulting in birth rate drop from 1.8 to 1.71, drastically increased number of parents sent their children away to foster families, temporary care centers or orphanages and failed to bringing them back home, and divorce rate increased due to conflicts caused by economic hardship (Hwang, 2000). According to a survey conducted in 1999, 11 per-cent of the respondents experienced some form of domestic violence after a major layoff in 1997. Homeless issue became a social problem for the first time since the Korean War (Kim, 1999).

Unemployment and education interacted with each other. After the crisis, many companies in Korea switched from hiring regular workers to hiring non-standard workers, reaching 20 per-cent of the total worker population in 1999, who were not provided with compensation, benefits, or job security (Shim, 1999). Economic crisis especially increased young populations' unemployment rate. The collapse of the middle class resulted in many college students dropping out to support their family. They could not compete in tougher job competition owing to lack of education, and eventually became either unemployed or nonstandard workers, resulting in a vicious circle.

Work-related culture was drastically affected as well. The lifetime employment tradition that had ensured job security since the beginning of Korea's industrialization was abandoned by most companies in order to survive in the extremely competitive period. The cessation of lifetime employment suddenly goaded the Korean people into meeting very high level of competition in the job market, which subsequently changed people's attitude toward work values dramatically. These social changes have left many middle aged Korean workers with worry, anxiety, and extremely high rates of competition and unemployment (Yoo, 2000).

The political environment between 1997 and 2000 was also characterized with crisis, turmoil, and instability. A series of political corruptions (mostly originated from the previous regime) instigated conflicts between the conservatives and the liberalists, resulting in a continuously unstable political situation (Kim, 2004). Revolutionary progress in technology was another important aspect of social change in Korea during this period. Around year 2000, due to high-rocketed development in the computer and high-tech industry, a lay person's life in Korea also changed drastically; becoming very closely connected with the use of the technology. It is reported that faced with such rapid changes in technology, middle-aged workers of Korea developed an alarmingly increased rate of phobia and anxiety since they were less capable of catching up with the latest technology (Yoo, 2000).

Therefore, social changes in Korea reviewed here indicates that Korea experienced significant changes throughout most social areas during this period of time (Jang, 2003; Kim, 2004) and, therefore, leads to a prediction that the Korean people were notably traumatized by such changes in society.

Preliminary study

Before evaluations of social change at pace and scope were measured, a preliminary study was conducted to identify the types of social changes that were perceived as significant by the lay people. In previous studies on social change, researchers chose what types of social changes they would focus on, through a priori judgment. The choice of social change types was rarely driven from lay people's perspectives. Although the researchers' insight is important, this arti-

cle is more interested in lay people's subjective experiences. As reviewed (Dorfel-Baasen & Rauh, 2001; Kameoka & Marsella, 1999; Sztompka, 2000), certain social changes seem more important to some people than others at any given time. Therefore, the preliminary study aimed to identify the types of social changes perceived as most significant from lay people's perspectives.

Ninety-six people participated in the preliminary study. The participants were randomly chosen and contacted from a local telephone directory. On participants' agreement, an open-ended survey was mailed to each participant. In the open-ended survey, participants were asked to think of specific social changes which had occurred most recently or were still occurring in Korea, and list as many as they could.

Analysis was conducted in two steps. First, participants' responses to the open-ended questionnaire were sorted into several social categories. For example, "*income drops*" and "*unemployment increases*" were placed in the category of economy. Two graduate students from the psychology department participated in the coding process. The items for social changes were first coded by each graduate student and then were later compared against each another. As a result, five social areas emerged: politics, economy, health and welfare, technology, and crime.

In the second step, for each of the social changes in the five categories, the number of participants that listed them was counted. This technique deduced the relative importance of each type of social change compared to changes occurring in other social areas. Table 1 presents the list of social changes. Social changes listed by 50 or more participants (out of 96 participants) were included in Table 1. It was assumed that the more frequently an item was listed, the more important the item was in regard to the type of change. The largest number of participants reported changes in economy, suggesting that the most significant types of changes occurred in this area. On average, social changes in economy were listed by 76 participants. Among the listed items, the most frequently listed change was "*economic crisis*" (listed by 90 participants), which confirmed that social changes in economy was the most significant type of changes. The specific types of social change listed in Table 1 were used in the main study to assess three aspects of social change: scope, pace, and evaluation.

Table 1: List of significant types of social changes in Korea (N = 96)

Social area	Type of Social Change	Number of respondents
Politics	1. Democratization through change of political regime	(81)
	2. Political corruption	(76)
	3. Increase of disinterest in politics	(73)
	4. Increase of regional conflicts	(70)
	5. Decrease of political protests	(65)
	6. Increase in activities of non-governmental organizations	(55)
	7. Decrease of political ideology conflicts	(53)
		M = 68
Economy	1. Economic crisis	(90)
	2. Increase of unemployment rate	(84)
	3. Income drops	(81)
	4. Collapse of middle class	(80)
	5. Increase of the homeless	(73)
	6. Inflation	(71)
	7. Increase of people in poverty	(66)
	8. Collapse of life long employment system	(53)
	9. Collapses of plutocratic corporations (economic moguls)	(50)
	M = 72	
Health and Welfare	1. Development in use of biomedical technology	(79)
	2. More access to health services	(74)
	3. Increase of number of mental patients	(65)
	4. Increasing supplies of medicare services	(61)
	5. Increase of health care expense	(52)
	M = 66	
Technology	1. Development of computer/internet technology	(91)
	2. Development of technology (other areas but computer technology)	(88)
	3. Popular use of technology (e.g., cellular phone)	(83)
	4. Virtual/online culture	(71)
	5. Booming of online and dot.com business	(64)
	6. Increase of internet café	(59)
	M = 76	
Crime	1. Increase of violent crimes (e.g., murder increases)	(76)
	2. Increase of computer crimes (e.g., virus, internet fraud, hacking)	(72)
	3. Increase of sex crimes crime	(62)
	4. Increase of gangviolence	(57)
	5. Increase of hate crime	(53)
	6. Increases of adolescent criminals	(51)
	M = 62	

Note: Numbers indicate the frequency by which each social change was listed by participants. Only examples of social changes listed by more than half participants are included.

Main study

The preliminary study revealed the types of social changes that were perceived as significant to the Korean people. Based on these findings, the main study assessed the Korean people's perception of social changes at three levels (pace, scope, and evaluation) and examined how they were related to coping resources and psychological well-being. In the main study, 250 people (141 males, 56.4%, mean age = 31.4, $SD = 6.3$; 109 females, 43.6%, mean age = 28.7, $SD = 5.2$) working at various companies located in Seoul, the capital city, participated in the survey.

Measurements

Perceived Social Change. To measure the perceived scope of social change, different types of changes, which were revealed as important in the Preliminary study, were listed throughout the five social areas (politics, economy, health and social welfare, technology, and crime). Survey participants reported their subjective evaluations about the scope and magnitude of each social change (e.g., "To what extent is [increase of poverty population] happening in our society?"). Pace of social change was measured in a similar fashion except that it focused on the pace of change. Participants reported their subjective evaluations about the pace of each social change in the five social categories (e.g., "How fast or slow is [increase of poverty population] happening in our society?"). Participants also reported how they evaluated each social change in the five social areas (e.g., "how desirable or undesirable is [increase of poverty population]?"). The scales used for all measures of perceived social change ranged from 1 to 6.

Psychological Well-Being. *Satisfaction with life* was measured by using the Satisfaction with Life Scale (Diener, Emmons, Larsen, & Griffin, 1985), *Satisfactions with different life domains* (health, marriage, family, finances, job, friends, housing, and leisure) were also measured. *Positive emotions* were measured by using four words indicating the emotional states (happiness, confidence, peace, and optimism), and *Negative emotions* were measured by using five words indicating the negative emotional states (anger, fear, sadness, shame, and anxiety). In addition, *Psychosomatic symptoms* were also measured because it is known that people in Korea often display their mental states through psychosomatic symptoms. Eight symptoms (headache, acid stomach, insomnia, increased heartbeat, heartburn, loss of appetite, heartburns, and feeling heavy) were measured. These symptoms, which were often reported by the Koreans (Shin, 1998), were selected from the Brief Symptom List (Derogatis & Spencer, 1992). Measures for psychological well-being were assessed using 6-point scale.

Coping Resources. *Self-efficacy* was measured by using the Self-Efficacy Scale which was developed by Sherer et al. (1982). *Self-esteem* was measured

by using the Self-Esteem Scale (Rosenberg, 1965), which was designed to measure the global feeling of self-worth or self-acceptance. *Social support* was measured by using the Provision of Social Relations (Turner, 1992). Measures for coping resources were assessed using 6-point scale.

Results

First, descriptive analysis of the perceived social change was conducted (Table 2). Because it was predicted that social change would be perceived at three different dimensions and the changes in different social areas would be viewed by participants to a different extent, the evaluations of social changes were compared across different social categories.

Table 2: Evaluations of Social Change in Korea by Different Social Areas

	Scope of Change		Pace of Change		Evaluation of Change	
	<i>M</i>	<i>SD</i>	<i>M</i>	<i>SD</i>	<i>M</i>	<i>SD</i>
Politics	2.64	1.44	2.12	1.28	3.09	1.31
Economy	4.94	1.22	4.20	1.33	3.11	1.29
Health and Welfare	3.39	1.28	3.12	1.25	3.28	1.31
Technology	4.80	1.24	4.70	1.66	2.66	1.31
Crime	4.20	1.84	4.35	2.11	3.10	1.27

Note. 1. *N* = 250.

2. Scope of social change (1= not at all, 6 = very much); pace of social change (1= very slow, 6 = very fast), evaluation of change (1 = very positive, 6 = very negative).

As predicted, it was found that overall evaluations of social change in three aspects differed across social categories. In the ‘pace of change’ dimension, technology was perceived as the most rapidly changing social area ($M = 4.70$, $SD = 1.66$) followed by economy ($M = 4.20$, $SD = 1.33$) and crime ($M = 4.35$, $SD = 2.11$). In the ‘scope of change’ dimension, economy was perceived as the greatest scope change ($M = 4.94$, $SD = 1.12$). The scope of change in politics was viewed as the least changing ($M = 2.64$, $SD = 1.44$). ‘Evaluation’ of social change showed different patterns. The changes in health and social welfare were viewed most negatively ($M = 3.28$, $SD = 1.31$).

A repeated measure analysis of variance (ANOVA) showed that pace, scope, and evaluation of social change differed significantly across five social areas. The evaluations of social change also differed across five social areas.

Thus, the results of the descriptive analysis indicate that participants perceived the same type of social change to a different extent in the three dimensions of social change (i.e., pace, scope, and evaluation). This indicates that the survey participants perceived three aspects of social change as qualitatively different dimensions. For example, one may perceive the pace of change in the

economy as the fastest, but he or she may evaluate social change in other social areas more negatively.

Structural equation model analysis was employed to examine the multiple relationships among the perceived social change, evaluation of social change, psychological well-being, and coping resources. This statistical technique provides knowledge on how well the proposed model would fit with the collected data. The analysis consists of two parts: constructing a measurement model and performing latent model tests. The measurement model examines how well theoretically constructed variables are well measured by the observed variables that were actually used. The structural model examines the interrelationships among latent variables that are built with the observed variables.

As a result, the fit indices of the measurement model indicated that the initial model was acceptable, $\chi^2(231, N = 250) = 695.81, p < .001, \chi^2/df = 2.96, NFI = .95, TLI = .97, CFI = .98, RMSEA = .06$ (90% CI: lower bound = .08, upper bound = .04). Factor loadings of indicators ranged from .52 to .97, presenting a satisfactory model fit.

Following the measurement model analysis, a latent model test was conducted to examine the mediation process of the evaluation of negative social change. The Korea study examined several competing models that had different patterns of path connections among the variables to find a best fitting model. The initially proposed model predicted that the evaluation of social change would act as a mediating variable between the perceived pace and scope of social change and psychological well-being, as well as between coping resources (social and personal) and psychological well-being (well-being and ill-being). It was also predicted that social resources would be mediated through personal resources.

The initial model reported a satisfactory model fit but was revised in minor by examining the model fit of competing models. As a result, it was revised into a hybrid model that includes direct paths and mediation paths from coping resources. Because the path from personal resources to psychological well-being was highly significant in the model modification process, the final model added direct paths from personal resources to well-being and ill-being. The model predicted both mediation and direct influence from personal sources to well-being and only mediated influence from social resources. The final model is presented in Figure 2.

Final model had a satisfactory model fit; $\chi^2 = (263, N = 250) = 678.46, p < .001, \chi^2/df = 2.83, NFI = .96, TLI = .97, CFI = .98, RMSEA = 0.04$ (90% CI: lower bound = .01, upper bound = .05). In the model, 26.31 percent of the variance in well-being and 51.20 percent of the variance in ill-being were explained by the combination of the perceived scope, pace, and evaluation of social change.

Figure 2: Final structural model of social change and psychological well-being in Korea

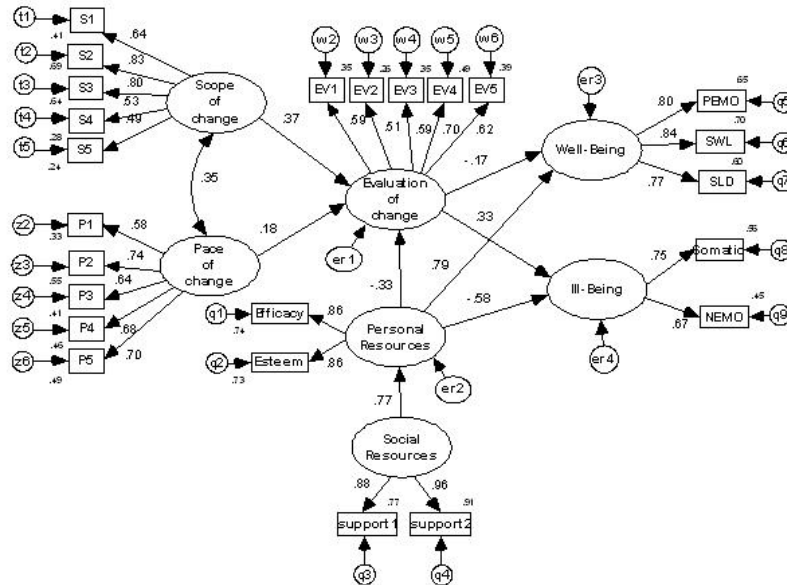

Note:
 1. N = 250
 2. PEMO = Positive Emotion, SWL = Satisfaction with Life, SLD = Satisfaction with Life Domains, Somatic = Somatic Symptoms, NEMO = Negative Emotions.
 3. All path coefficients are significant at $p < .01$
 4. Model fit indices: $\chi^2 = 678.46^{***}$, $df = 240$, $\chi^2/df = 2.83$, NFI = .96, TLI = .97, CFI = .98, RMSEA = .05, CI for RMSEA = .03 (lower), .05(upper)

Several noteworthy findings emerged from the final model. First, both scope and pace of social change were inversely related to the evaluation of social change, which indicated that the more rapidly and to a greater scope people perceived the occurring social change, the more negatively they viewed the social change. Second, two major mediation processes by the evaluation of change were revealed. The evaluation of social change mediated the relationship between the perceived scope and pace of social change and psychological well-being (well-being and ill-being). Direct paths were not found between the perceived pace and scope of social change and psychological well-being. The evaluation of social change also mediated personal resources and psychological well-being. The connection between personal resources and well-being and ill-being mediated through the evaluation of social change ($\beta = -.17$, $p < .001$) for

well-being and ($\beta=.33, p < .001$) for ill-being, although they had direct paths to well-being ($\beta=.79, p < .001$) and ill-being ($\beta = -.58, p < .001$). As predicted, social resources were highly associated with personal resources ($\beta=.77, p < .001$), indicating that people with more perceived social resources would have a higher sense of personal resources. These results supported the predication that the evaluation of the stressors is a key to health outcome results, which are based on the availability of coping resources.

The second analysis in Korea Study was performed to examine the moderation effects by the coping resources. Both personal and social resources have been demonstrated as moderators to buffer the impact of stress on psychological well-being (Cohen & Wills, 1985; Jex & Bliese, 1999; Pinquart, et al., 2004). Mediation and moderation models have both advantages and disadvantages. In general, the mediation model is informative on the questions such as ‘how are variables related with each other?’ by explaining multiple structural relationships among different variables in the model (Baron & Kenny, 1986). For example, it is informative to know that personal resources influence well-being indirectly through the mediation of the evaluation of negative social change. However, interpretations from a mediation model are often limited to depicting correlation based relationships. A mediation model can be vulnerable to conceptual confusion due to possible correlations between variables in a model. Some theorists view coping resources, such as self-esteem, as indicators of psychological well-being (Baron & Kenny, 1986). Therefore, any correlation between well-being and coping resource measures may confuse an explanation about the power of coping resources in stress reduction. As a result, this study also tested for moderation effects of personal and social resources following the mediation model test. Testing both mediation and moderation effects in one study is not unusual and is found recently in some studies (Wei, Mallinckrodt, Russell, & Abraham, 2004) and such method would provide more in-depth knowledge of coping resources’ effects.

To test the moderation effects by coping resources, multi-group analyses were performed for each of the three coping resources, respectively. In order to conduct multi-group analyses, the sample was divided into two groups based on whether the participants scored above or below the median score on each of the coping resource measures. The baseline unconstrained model, in which all structural paths were freely estimated, was then compared with the constrained model, in which all structural paths (those between the latent constructs) were constrained to be equal. In this procedure, if the unconstrained model and the constrained model showed significant difference in the Chi-square test, it can be interpreted that the difference is due to the constrained factor. The results of difference tests between the unconstrained models and the model with all path constrained are presented in Table 3(a). For self-efficacy as the moderator, the Chi-square difference between the two models was $\Delta\chi^2(49) = 344.92, p < .001$. This indicated that the structural paths were not invariant across two groups.

The differences were also significant across high and low groups of self-esteem ($\Delta\chi^2(49) = 388.72, p < .001$) and social support, $\Delta\chi^2(49) = 309.78, p < .001$, indicating that all coping resources had moderating effects on structural paths. In multi-group analysis of SEM, an extra step is taken to compare constrained and unconstrained models. If the constrained model is judged to be different from the unconstrained model, the unconstrained model is again compared to a series of other constrained models where each of the structural paths is constrained at equal statuses to discern which structural path is not invariant. The difference is interpreted as being caused by the specific path.

Table 3(b) illustrates the changes in path coefficients that indicate whether the paths between the evaluation of social change and psychological well-being were changed by different levels of coping resources. Inspection of changes in path coefficients showed that coping resources buffered the impact of evaluation of negative social change on well-being and ill-being.

The only non-significant difference was the path between evaluation of change and well-being, which indicated a slight improvement on well-being, but was not at a significant level. The path coefficient between the evaluation of social change and well-being became significantly smaller in the high coping resource group. The test of invariance of structural path on the evaluation of negative social change to ill-being showed similar results.

Discussion

Two important results were obtained from the Korea Study. First, the subjective evaluation of social change was significantly related with psychological well-being. Second, it also revealed that the employing the theoretical model, Transactional Model of Stress, was valid to explain the relationship. Evaluation process of social change mediated the perceived pace and scope of social change on psychological well-being. And this evaluation was influenced by the perceived extent of coping resources. The moderation effects of coping resources were also found. All together, the Korea study showed initial confirmation that the focus on individuals' subjective experience is a valid approach.

Results of multi-group analysis and moderation effect by coping resources

Table 3 (a): Model fit indices

Moderating Variable	Model compared	χ^2	df	χ^2/df	$\Delta\chi^2$	$\Delta\chi^2/\Delta df$	NFI	TLI	CFI	RMSEA
Self-efficacy	Unconstrained model	1250.15	482	2.59			.94	.95	.97	.08
	Path coefficients constrained to be equal	1595.07	531	3.00	344.92	7.03***	.92	.93	.91	.08
Self-esteem	Unconstrained model	1254.49	482	2.06			.95	.96	.94	.09
	Path coefficients constrained to be equal	1643.21	531	3.09	388.72	7.93***	.90	.93	.92	.09
Social support	Unconstrained model	1129.28	482	2.34			.94	.92	.96	.08
	Path coefficients constrained to be equal	1439.06	531	2.71	309.78	6.32***	.92	.95	.93	.09

Table 3 (b): Changes in standardized value for moderation effect

Path in structural model	Changes in standardized path coefficients				
	Self-efficacy		Self-esteem		Social support
	Low	High	Low	High	Low to high
Scope → evaluation	.46	→ .41 (ns)	.41	→ .19 (***)	.24 → .32 (*)
Pace → evaluation	.15	→ .12 (ns)	.19	→ .08 (***)	.33 → .09 (***)
Evaluation → well-being	-.19	→ -.22 (ns)	-.43	→ -.07 (***)	-.21 → -.08 (***)
Evaluation → ill-being	.67	→ .19 (***)	.71	→ .07 (***)	.49 → .07 (***)
Personal → well-being	.78	→ .68 (***)	.60	→ .53 (ns)	.78 → .63 (**)
Personal → ill-being	-.34	→ -.64 (***)	-.27	→ -.59 (***)	-.48 → -.67 (***)
Social → personal	.84	→ .51 (***)	.81	→ .43 (**)	.86 → .64 (***)

Note.

1. $\Delta\chi^2$ represents the difference in chi-square between unconstrained model and the specific model in question;
2. NFI = Bentler-Bonnet Fit Index, TLI = Tucker-Lewis Index, CFI = comparative fit index; RMSEA = roots mean square error of approximation
3. Pace = pace of social change, scope = scope of social change, evaluation = evaluation of social change, person = personal resources, social = social resources
4. All individual paths were significant for both subgroups.
5. * $p < .05$, ** $p < .01$, *** $p < .001$

Hong Kong study: Replication and validation of Korea study

The next study focused on the Hong Kong society. The Hong Kong study was conducted to examine the validity of the structural model that was supported in Korea. To become a general model, the model proposed in Korea Study should be valid in other countries that also experienced significant social changes regardless of the type of social changes.

Hong Kong was chosen as the venue for this purpose because the country experienced a historical social change: the reunification with the People's Republic of China in 1997. As scholars studying the German case pointed out, unification is a prototype of abrupt social change. Hong Kong had been a colony of the British for almost 200 years. From the Tiananmen Incident in 1989 to Hong Kong's own political reform in 1992 and its later reunification with the PRC in 1997, in the short span of ten years, Hong Kong has experienced many critical social changes. However, the reunification was, in many ways, the climax of these changes. The reunification was not only a symbol of the end of British colonial rule, but was simultaneously an important political experiment: two ideologies, capitalism and communism, would henceforth coexist in one country for the next 50 years. Many cross-cultural studies pointed out that Hong Kong society has been westernized during the colonial period, resulting in the development of an independent national identity and social culture very different from those of PRC's (Chiu & Liew, 2000).

Hong Kong's reunification was followed by various social changes such as economic recession, an increase in unemployment rate, changes in Hong Kong citizens' social identity, as well as the change of its political situation (Abram, Hinkle, & Tomlins, 1999; Chiu & Liew, 2000; Lui, 1999). These changes influenced individuals' lives and plans for the future. For example, since 1989, anticipating the reunification, about 60,000 Hong Kong Chinese emigrated steadily to Canada, the United States, and Australia because of the uncertain future of Hong Kong (Wong, 1994; Salaff & Wong, 2000). It seems that people in Hong Kong developed a sense of the future of Hong Kong and then made personal decisions about their own futures based on their evaluations of the past social changes occurring since the reunification.

Furthermore, social changes in Hong Kong are a continuous process. Indeed, many social indicators show that social changes in Hong Kong are still in progress. For example, the 2002 report of the Hong Kong Transition Project, which has surveyed people's opinions on a variety of social events in Hong Kong, shows that social turmoil still exists. This report shows that Hong Kong people's concerns about the economic situation, which again turned sharply negative around July 2001, although there was no significant triggering event in China in 2001. The number of pessimists increased from 6 percent in 1997

to 41 percent in 2001, while the number of optimists dropped from 62 percent to 24 percent. Unemployment rate rose to 7.7 percent during the period of April to June in 2002. Dissatisfaction with government increased to 68 percent from 35 percent, its lowest point in January 1998, since the reunification. These social indicators indicate that the anxiety and worry levels currently affect the Hong Kong people's sense of well-being.

Method

Research method in the Hong Kong study was overall the same as that in the Korea study to examine the validity of the Korea study's theoretical model. The social changes were measured through individuals' subjective evaluations. Compared with the Korea Study, there were few differences. The first difference was that in choosing major types of social changes, five social areas were chosen but social welfare was chosen instead of the changes in technology because literatures indicated that social welfare system and benefits changed to a great extent after the reunification (Lui, 1999). A preliminary method similar with the Korea study was used to find the significant type of social changes. The second difference was that the Hong Kong study used shorter form of measurements. The data in the Hong Kong study was collected through a telephone survey. Due to the nature of telephone survey, the questionnaire used in the Korea study was modified to be of a shorter form. The third difference was that the scope of social change was not measured in the Hong Kong study. This was due to the delicacy of translation. The scope or extent of social change did not have exact matching words in Chinese. To measure psychological well-being, items from the *Satisfaction with Life Scale* (Diener, Emmons, Larsen, & Griffin, 1985) and the *Chinese Affect Scale* (Hamid & Cheng, 1996) were used. Perceived self-efficacy was used to measure psychological resource, and perceived social support was used to measure social resource. To measure personal resources, the Chinese version of *General Self-Efficacy Scale* (Cheung & Sun, 1999) was used. For social resources, the *Provision of Social Relations* (Turner, Frankel, & Levin, 1983) was used. Because there was no Chinese version of this measure, the *Provision of Social Relations* was translated into Chinese and checked by back translation.

In the Hong Kong Study, 200 people responded to the survey. The number of female participants ($N = 106$, 53 %, average age = 38.23) was slightly larger than male participants ($N = 94$, 47.0 %, average age = 36.82). Since approaching the reunification, Hong Kong people's social identity showed changes and the self-reported identity was 'Hongkonger' (19.0 %), 'Hongkonger, only secondary Chinese' (28%), 'Chinese' (17.5%), and 'Chinese, only secondary Hongkonger' (35.5%) in this study, indicating that single social identity increased. Employment status was that 89.5 percent were employed and 10.5 percent were unemployed.

Results

A descriptive analysis reported in Table 4 show the participants' general evaluations of social changes. The participants felt that the overall social changes in Hong Kong ($M = 3.16$, $SD = 1.10$) had occurred rapidly since the reunification. The participants' evaluation of the overall changes in Hong Kong was not positive in general. Participants reported that Hong Kong had become a worse place after reunification ($M = 3.86$, $SD = 1.02$) and was also changing for the worse ($M = 3.89$, $SD = 1.11$).

Table 4: Evaluations of Social Change in Korea by Different Social Areas

Evaluation	Overall		Economy		Politics		Social Welfare		Education		Housing	
	<i>M</i>	<i>SD</i>	<i>M</i>	<i>SD</i>	<i>M</i>	<i>SD</i>	<i>M</i>	<i>SD</i>	<i>M</i>	<i>SD</i>	<i>M</i>	<i>SD</i>
Pace	3.16	1.10	3.66	1.22	3.61	1.09	3.42	1.15	3.28	1.40	3.22	1.32
Evaluation	3.89	1.11	4.81	.74	3.81	1.09	3.39	1.02	3.69	.97	3.52	1.17

Note. Pace of social change (1 = very slow, 5 = very fast); Evaluation: Evaluation of social change (1 = much better, 5 = much worse)

The participants' perceived pace of change and their subsequent evaluations of changes varied according to different social areas. The participants reported that the changes in economy were the fastest ($M = 3.66$, $SD = 1.22$) and for the worse ($M = 4.81$, $SD = 0.74$) compared to the other social areas. A repeated measure one-way ANOVA showed significant differences in the perceived paces, $F(3.99, 7.39) = 6.11$, $p < .001$ and in the evaluation, $F(3.82, 15.11) = 29.05$, $p < .001$ of different social areas. A post-hoc analysis showed that excluding the comparison between education and housing, all the social areas were perceived to be significantly different from each other, both in the pace of changes and in the evaluations of these changes.

As examined in the Korea Study, the complex relationships among the perceived social changes, the evaluations of social changes, well-being, and ill-being were examined by two-step structural equation modeling analyses: measurement model and latent model tests.

Measurement model was acceptable with a good fit: $\chi^2(280, N = 200) = 299.26$, $\chi^2/df = 1.01$, GFI = .95, TLI = 0.96, CFI = 0.96, RMSEA = .03 (90% CI: lower bound = .01, upper bound = .04) and measurement variables proposed in initial model remained with no item dropped. As in the Korea study, the Hong Kong study also revealed as the final model, a hybrid model that predicted both direct paths from personal resources and mediations through the evaluation of social change to well-being and ill-being. Final model revealed a good model fit. ($\chi^2 = 312.15$, $df = 285$, $\chi^2/df = 1.09$, GFI = .94, TLI = .97, CFI = .97, and RMSEA = .02, CI: lower bound = .00, upper bound = .03). All paths in

this model were significant ($p < .01$). Thus, the final model was accepted as the best fitting model and further model modification was not made.

The final model for Hong Kong social change and all path coefficients are presented in Figure 3. Several important findings in the Hong Kong study are as follows. First, the evaluation of social change plays an important mediation role. The pace of social change directly influences the evaluation of social change ($\beta = -.56, p < .01$), which indicates that the faster people perceived social changes in Hong Kong, the more negatively they evaluated the changes. In support of the proposed model, the evaluation of social changes in turn increases well-being ($\beta = .20, p < .01$) and decreases ill-being ($\beta = -.20, p < .01$). In the model, the direct effects of the pace of social change almost disappeared when they were mediated by the evaluation of social change (indirect effect = $-.30$ on well-being and $.15$ on ill-being; direct effect = $.00$ on well-being and $-.10$ on ill-being). The evaluation of social changes also mediates the effects of personal resources on psychological well-being. However, the direct effects of personal resources (direct effect = $.63$ on well-being, $-.30$ on ill-being) are larger than indirect effects (indirect effect = $.10$ on well-being and $-.12$ on ill-being), supporting the idea that the hybrid model is the best model for the data. The direct effects of social resources on psychological well-being are not significant ($\beta = .06, ns$) and therefore it would appear that most effects by social resources are mediated through personal resources.

Figure 3: Final structural model of social change and psychological well-being in Hong Kong

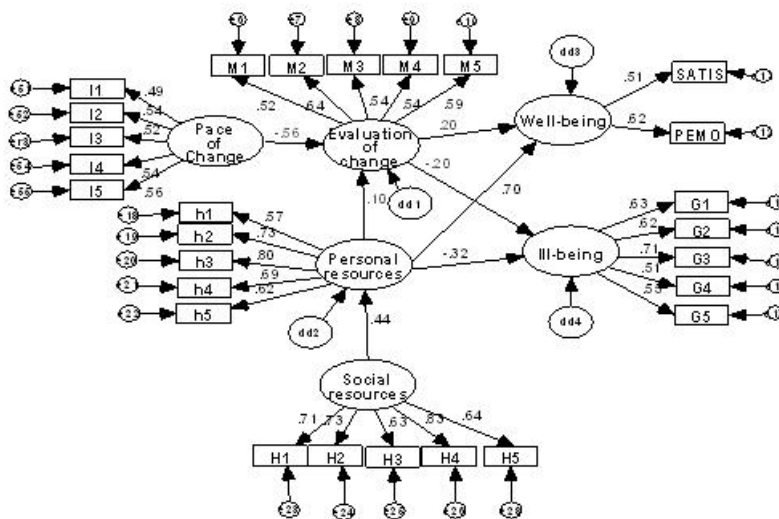

Note. 1. Model fit indices: $\chi^2 = 312.15, df = 285, \chi^2/df = 1.09, GFI = .94, TLI = .97, CFI = .97,$ and $RMSEA = .02, CI: lower bound = .00, upper bound = .03.$

Discussion

Findings in the Hong Kong Study supported the Korea Study. Perceived social changes had a significant relationship with psychological well-being. The relationship between the perceived social change and psychological well-being was mediated by the evaluation of social changes, in which the coping resources played a key role. Adaptation of the Transactional Model of Stress was validated in the Hong Kong Study, too. Although the scope of social change was not assessed in the Hong Kong Study, the theoretical model proposed in the Korea Study was supported by the Hong Kong data. Because the data in the Hong Kong study was collected through telephone survey, the generalization of findings was strong. Although the types of social changes were somewhat different, the evaluation of alterations, occurring in major social areas, had a similar relationship with psychological well-being, suggesting that the proposed theoretical model is reliable.

Overall Discussion

Social change may be an integral part in people's psychological well-being not only as an objective social event, but also as a subjective event. The evaluation of social changes may influence individuals even before the actual social change touches their lives and alters their lively conditions. Although the evaluation of significant social changes and its relationship to people's psychological well-being is an important question, there is a lacuna in this area of research. In this context, studies conducted in Korea and Hong Kong revealed insightful knowledge on the given question.

The studies reported in this article have several points that are worthy of discussion. First, both studies showed that the faster and the more negatively changes are perceived, the less well-being and more ill-being is experienced. It is important to note that the evaluations of social change, not the experiences of actual social changes, were solely related with psychological outcomes. It was concluded that the individuals' subjective experience functions as a medium to interconnect the influence of changes at the societal level with individual's psychological outcome. Findings from two studies are consistent with Sztompka's (2000) view that the subjective experience of social change brings psychological trauma even if it does not concretely affects the individuals' life conditions. The findings indicate that, although not clinically traumatized, the psychological well-beings of the people in Korea and Hong Kong are significantly affected by their evaluation of various changes in their society. This argument is not a new idea. Similar sociological theories were proposed by Durkheim (1951) and Lauer and Lauer (1976) as well as by the well known futurist, Toffler (1980) along with Hegelian and Marxian's view on dialectical social development. However, all these theories were proposed mostly at a

theoretical level, awaiting empirical tests. This article provides systematic empirical examinations and support for these previously proposed theories. The importance of the findings is that it recognizes the evaluation of social change as a significant social stressor, which was rarely highlighted in previous studies. There are numerous studies on stress in psychology and related areas (26,725 articles with the word 'stress' in the title were scanned in the PsyINFO Database). The majority of researchers focused on the individuals' major life events (for review see Werner & Frost, 2000) but few acknowledged social changes as an important stress factor. We are witnessing the rapid increase of the connections between individuals and society today. Due to the development of communication media, people's awareness of social changes is keen today and the susceptibility to potential threat from these changes has been increased drastically. This article verified such an idea, by showing through a stress theory, how changes at a societal level can be connected to individuals' mental health.

The second major question in two studies, which encompass multiple structural path relations, was is there a relationship between the evaluation of social change and psychological well-being? This question was approached by testing two types of mediating effects of the evaluation of social change: the first between the pace of social change and well-being, and the other between coping resources and psychological well-being. This question also tests whether the Transactional Theory of Stress is a valid theoretical tool in understanding social change and psychological well-being. The results of the two studies consistently supported the Transactional Theory of Stress (Lazarus & Folkman, 1984) in that it proposes the mediating effects of the appraisal of resources. The evaluation of social change significantly mediated the influences of coping resources on psychological well-being. Thus, the proposed prediction concerning mediation effects was supported. Therefore, it may be concluded that the Transactional Theory of Stress is a conceptually valid tool to explain the relationship between social change and psychological well-being.

In summary, the two studies reported in this article showed that the use of subjective evaluation to assess social change at individual level is a reliable measurement technique. Throughout the studies, subjective evaluation consistently showed significant explanation in variance in psychological well-being, thus supporting the importance of subjective experience, both theoretically and methodologically. As found in studies conducted in European countries reviewed in introduction, social change studies are rare in psychology or limited to macro approach in sociology. The two studies conducted in the Asian countries that experienced significant social changes provided confirmation that measuring subjective experience is a good tool to study the impact of significant social changes.

Limitation and conclusion

The first limitation is that because the structural equation modeling does not test causal relationships, the findings in this study still leaves the possibility that the level of psychological well-being may reversely affect people's evaluations of social change. For example, Noack et al. (2001) found that level of satisfaction with political situation influenced the perceptions of uncertainty and pace of social change among German adolescents. Testing this view was not conducted in this study because it was beyond the scope of the main thesis of this study and due to the constrained space. Yet, it should be noted that examining any causal relationship between the evaluation of social change and psychological well-being will be necessary in future studies. This type of limitation is related with the analysis in the Korea Study that examined mediation effects by coping resources based on one sample. Mediation model in such is basically a correlation model, so this method cannot fully exclude the possibility that other factors can affect dependent variables, which may result in pseudo-mediation effect. This limitation can be resolved in an experimental design that we recommend a future study will need to handle.

Second limitation is that people's actual experience of social change was not measured. The results in the two studies do not ignore or underestimate the impact of actual experience of social change. It is desirable that both actual and perceived change be studied together in a series of studies to understand the full relationship between social change and psychological well-being. Because the main purpose of the studies was to theorize the importance of the subjective evaluation of social change, primary focus was given to the subjective evaluation of social change that had been neglected in previous researches. Future research must integrate both actual and subjective experiences of social changes.

In conclusion, this article claims, first, that the evaluation of social change are a significant social stressor to understand the influence of rapid social change on psychological well-being. Secondly, this article confirmed that the Transactional Model of Stress is an integral conceptual tool to understand the complex dynamic of social change's impact on psychological well-being by adopting a new approach.

References

In English

- Abram, D., Hinkle, S., and M. Tomlins. 1999. Leaving Hong Kong?: The roles of attitude, subjective norm, perceived control, social identity and relative deprivation. *International Journal of Intercultural Relations* 23 (2): 319-338.
- Adwin, C. M., and T. A. Revenson. 1986. Vulnerability to economic stress. *American Journal of Community Psychology* 14: 161-175.

- Albrow, M.. 1996. *The global age*. Cambridge: Polity Press.
- Balakrishna, S.. 1993. The new Russia: The challenge of psychological changes. *Humanistic Psychologist* 21: 180-186.
- Bandura, A..1997. *Self-efficacy: The excise of control*. New York: Freeman.
- Banks, M. H., and P. Ullah.1988. *Youth unemployment in the 1980s: Its psychological effects*. London: Croom Helm.
- Baron, R. M., and D. A. Kenny. 1986. The moderator mediator variable distinction in social psychological research: Conceptual, strategic, and statistical considerations. *Journal of Personality and Social Psychology* 51 (6): 1173-1182.
- Bartley, M.. 1987. Research on unemployment and health in Great Britain. In *Unemployment, social vulnerability, and health in Europe*, ed. D. Schwefel, P-D. Svensson and H. Zollner, 90-91. New York: Springer-Verlag.
- Brewer, M. B.. 1999. Multiple identities and identity transition: Implication for Hong Kong. *International Journal of Intercultural Relations* 23 (2): 187-197.
- Cheung, S-K., and S. Y. K. Sun. 1999. Assessment of optimistic self-beliefs: Further validation of the Chinese version of the General Self-Efficacy Scale. *Psychological Reports* 85: 1221-1224.
- Chiu, C. L. and L. H. Liew. 2000. *Uncertain future*. England: Ashgate Publishing Company.
- Cohen, S., and T. A. Wills. 1985. Stress, social support, and the buffering hypothesis. *Psychological Bulletin* 98: 310-357.
- Conger, R. D., and G. H. Elder, Jr.. 1994. *Families in troubled times: Adapting to change in rural America*. Hawthorne, NY: Aldine DeGruyter.
- Coolley, C. H.. 1902. *Human Nature and the Social Order*. New York: Scribner.
- Crockett, L. J. and R. K. Silbereisen. 2000. Social change and adolescent development: Issues and challenges. In *Negotiating adolescence in times of social change*, ed. L. J. Crockett and R. K. Silbereisen, 1-13. Cambridge, England: Cambridge University Press.
- Cutrona, C. E., and B. R. Troutman. 1986. Social support, infant temperament, and parenting self-efficacy: A mediation model of postpartum depression. *Child Development* 57: 1507-1518.
- Derogatis, L. R., and P. M.. Spencer. 1982. *The Brief Symptom Inventory (BSI)*. Baltimore, MA: Clinical Psychometric Research.
- Diener, E, R. A Emmons, R. J Larsen, S. Griffin. 1985. The Satisfaction With Life Scale. *Journal of Personality Assessment* 49 (1): 71-75.
- Doerfel-Baasen, D., and H. Rauh. 2001. Parents and teachers of young children under conditions of sociopolitical changes. *American Behavioral Scientist* 44 (11): 1818-1842.
- Dooley, D., and N. C. Catalano. 1980. Economic change as a cause of behavior disorder. *Psychological Bulletin* 87: 450-468.
- Durkheim, E.. 1997. *The division of labor in society*. New York: Free Press (Original work published 1893).
- Elder, G. H., and A. Caspi. 1990. Studying lives in a changing society: Sociological and personological explorations. In *Personality structure in the life course*, ed. R. A. Zucker, A. I. Rabin, J. Aronoff and S. J. Frank, 276-322. New York: Springer.
- Elder, G. H., Jr.. 1999. *Children of the Great Depression: Social changes in life experience*. Boulder, CO: Westview.

- Forkel, I., and R. K. Silbereisen. 2001. Family economy hardship and depressed mood among young adolescents from former East and West Germany. *American Behavioral Scientist* 44: 1955-1971.
- Gersten, J. C., T. S. Langner, J. G. Eisenberg, and L. Orzeck. 1974. Child behavior and life events: Undesirable change or changer per se? In *Stressful life events: Their nature and effects*, ed. B. S. Dohrenwend and B. P. Dohrenwend. 159-170. New York: Wiley.
- Hamid, P. N., and S. T. Cheng. 1996. The development and validation of an index of emotional disposition and mood state: The Chinese Affect Scale. *Educational and Psychological Measurement* 56 (6): 256-278.
- Harter, S.. 1986. Processes underlying the construction, maintenance, and enhancement of the self-concept in Children. In *Psychological perspectives on the self*, vol. 3, ed. J. Suls and A. Greenwald, 137-181. Hillsdale, MI: Erlbaum.
- Harter, S.. 1998. The development of self-representations. In *Handbook of child psychology: Social, emotional, and personality development*, ed. W. Damon and N. Eisenberg, 553-617. New York: John Wiley.
- Hatchett, L., R. Friend, P. Symister, and N. Wadhwa. 1997. Interpersonal expectations, social support, and adjustment to chronic illness. *Journal of Personality and Social Psychology* 73 (3): 560-573.
- Herman, J. L.. 1992. *Trauma and recovery*. New York: Basic Books.
- Hermans, H. J., and J. G. Kempen. 1998. The perilous problems of cultural dichotomies in a globalizing society. *American Psychologist* 53: 1111-1120.
- Hong, Y-I., C-Y. Chiu, G. Yeung, and Y-Y. Tong. 1999. Social comparison during political transition: Interaction of entity versus incremental beliefs and social identities. *International Journal of Intercultural Relations* 23 (2): 257-279.
- House, J. S., K. R. Landis, D. Umberson. 1988. Social relations and health. *Science* 241: 540-545.
- Ihle, W., G. Esser, M. H. Schmidt, B. Blanz, O. Reiz, and B. Meyer-Probst. 2001. Prevalence, course, and risk factors for mental disorders in young adults and their parents in East and West Germany. *American Behavioral Scientist* 44 (11): 1918-1936.
- Jang, J.. 2003. Economic crisis and its consequences. *Social Indicators Research* 62 (1): 51-70.
- Jex, S. M., and P. D. Bliese. 1999. Efficacy beliefs as a moderator of the impact of work-related stressors: A multilevel study. *Journal of Applied Psychology* 84: 349-361.
- Kameoka, V. A., and A. J. Marsella. 1999. Perception and consequences of social change among elderly Japanese American workers in Hawaii plantation community: a case example of individual withdrawal. *South Pacific Journal of Psychology* 10: 1-17.
- Kim, A. E.. 2004. The social perils of the Korean financial crisis. *Journal of Contemporary Asia* 34 (2): 221-238.
- Kim, J.. 2008. Perception of social change and psychological well-being: A study focusing on social change in Korea between 1997 and 2000. *Journal of Applied Social Psychology* 38: 2821-2858.
- Kim, J., and C-Y. Park. 2000. A study on the change of poverty as a result of economic crisis. *Public Economics* 5 (2): 223-249.
- Lauer, R. H.. 1991. *Perspectives on Social Change*. Boston: Allyn and Bacon.

- Lauer, R. H., and J. C. Lauer. 1976. The experience of change: Tempo and stress. In *Social change*, ed. G. K. Zollschan and H. Walter, 520-545. New York: Schenckman Publishing Company.
- Lawton, M. P., M. S. Moss, and M. H. Kleban. 1991. A two-factor model of caregiving appraisal and psychological well-being. *Journals of Gerontology* 46 (4): 181-189.
- Lazarus R. S., and S. Folkman. 1987. Transactional theory and Research on emotions and coping. *European Journal of Personality* 1: 141-70.
- Lazarus, R. S.. 1991. Progress on a cognitive motivational relational theory of emotion. *American psychologists* 46: 819-834.
- Lazarus, R. S., and S. Folkman. 1984. *Stress, appraisal, and coping*. New York: Springer.
- Lewin, K.. 1935. *A dynamic theory of personality*. New York: McGraw-Hill.
- Lui, T-L.. 1999. Hong Kong society: anxiety in the post-1997 days. *Journal of Contemporary China* 8 (20): 89-101.
- Major, B., C. Cozzarelli, A. M. Sciacchitano, M. L. Cooper, M. Testa, and P. M. Mueller. 1990. Perceived social support, self-efficacy, and adjustment to abortion. *Journal of Personality and Social Psychology* 59: 452-463.
- Marsella, A. J.. 1998. Toward a "global-community psychology": Meeting the needs of a changing world. *American Psychologist* 53 (12): 1282-1291.
- Mead, G. H.. 1934. *Mind, Self, and Society*. Chicago: University of Chicago Press.
- Meehan, M. P.. 1999. The structure of subjective well-being and its relationship to social support, perceived control, and life events in adolescence: A prospective analysis. *Dissertation Abstracts International* 60 (2). (UMI No. 95016).
- Merton, R., K.. 1996. Social structure and anomie. In *Robert K. Merton on social structure and science*, ed. P. Sztompka, 132-152. Chicago, IL: The University of Chicago Press.
- Morris, E. W.. 1998. Household responses to major economic change in Poland: A theoretical framework. *Journal of Family and Economic Issues* 19: 199-220.
- Newcomb, M. D., and K. Keefe. 1997. Social support, self-esteem, social conformity, and gregariousness: Developmental patterns across 12 years. In *Sourcebook of social support and personality*, ed. G. R. Pierce and B. Lakey, 303-333. New York: Plenum.
- Noack, P. and K. Boehnke. 1997. *Assessments of family experiences of social change in East and West Germany*. Unpublished Manuscript.
- Noack, P., B. Kracke, E. Wild, and M. Hofer. 2001. Subjective experiences of social change in East and West Germany: Analyses of the perceptions of adolescents and their parents. *American Behavioral Scientist* 44 (11): 1798-1817.
- Palaszewska-Reindl, T.. 1998. Polish households during the economic transformation. *Journal of Family and Economic Issues*: 19. 221-235.
- Pinquart, M., and S. Sorenson. 2000. Influences of socioeconomic status, social network, and competence on subjective well-being in later life: A meta analysis. *Psychology and Aging* 15: 187-224.
- Pinquart, M., and R. K. Silbereisen. 2004. Human development in times of social change: Theoretical considerations and research needs. *International Journal of Behavioral Development* 28 (4): 289-298.
- Pinquart, M., R. K. Silbereisen, and L. P. Juang. 2004. Changes in psychological distress among East German Adolescents facing German unification: The role of

- commitment to the old system and of self-efficacy beliefs. *Youth and Society* 36 (1): 77-101.
- Pyszczynski, T., and J. Greenberg. 1987. A biased hypothesis testing model of motivated attributional distortion. In *Advances in experimental social psychology*, vol. 20, ed. L. Berkowitz, 297-340. San Diego, CA: Academic Press.
- Rosenberg, M.. 1965. Society and the adolescent self-image. Princeton, New Jersey: Princeton University Press.
- Rosenberg, M.. 1985. Self-concept and psychological wellbeing in adolescence. In *The development of the self*, ed. R. L. Leahy, 205-246. Orlando, FL: Academic Press.
- Salaff, J., and S. Wong. 2000. Migration and identities in Hong Kong's transition. In *Hong Kong in Transition: The Handover Years*, ed. F. Ash, B. Hook and R. Porter. 247-268. London: Macmillan.
- Salzman, K. M., and C. J. Holahan. 2002. Social support, self-efficacy, and depressive symptoms: An integrative model. *Journal of Social and Clinical Psychology* 21 (3): 309-322.
- Sarason, I. G., H. M. Levine, R. B. Basham, and B. R. Sarason. 1983. Assessing social support: The Social Support Questionnaire. *Journal of Personality and Social Psychology* 44: 127-139.
- Sarason, I. G., B. R. Sarason, and G. R. Pierce. 1994. Social support: Global and relationship based levels of analysis. *Journal of Social and Personal Relationship* 11: 295-312.
- Schroeder, H.. 1997. Psychosocial stress and the process of coping among East German. In *Ethnicity, immigration, and psychopathology*, ed. I. Al-Issa and M. Tousignant, 121-133. New York: Springer.
- Sherer, M., J. E. Maddux, B. Mercadante, S. Prentice-Dunn, B. Jacobs, and R. W. Rogers. 1982. The self-efficacy scale: Construction and Validation. *Psychological Reports* 51: 663-671.
- Pinquart, M., R. K. Silbereisen, and A. Körner. 2009. Perceived work-related demands associated with social change, control strategies, and psychological wellbeing: Do associations vary by regional economic conditions? Evidence from Germany. *European Psychologist* 14 (3): 207-219.
- Sloutsky, V. M., and J. Searle-White. 1993. Psychological responses of Russians to rapid social change in the former U.S.S.R. *Political Psychology* 14: 511-526.
- Sztompka, P.. 2000. Cultural trauma: The other face of social changes. *European Journal of Social Theory* 3 (4): 449-466.
- Toffler, E.. 1980. *Third wave*. New York: Bantam Books.
- Tomasik, M. J., and R. K. Silbereisen. 2009. Demands of social change as a function of the political context, institutional filters, and psychological resources. *Social Indicators Research* 94: 13-28.
- Trommsdorff, G.. 2000. Subjective experience of social change in individual development. In *Adversity and challenge in life in the new Germany and in England*, ed. J. Bynner and R. K. Silbereisen, 87-122. Basingstoke, England: Macmillan.
- Turner, R. J.. 1992. Measuring social support: Issues of concept and method. In *The meaning and measurement of social support*, ed. Veiel and U. Baumann, 217-233. New York: Hemisphere Publishing Corporation.

- Turner, R. J., B. G. Frankel, and D. M. Levin. 1983. Social support: Conceptualization, measurement, and implications for mental health. *Research in Community and Mental Health* 3: 67-111.
- Wei, M., B. Mallinckrodt, D. W. Russell, and W. T. Abraham. 2004. Maladaptive perfectionism as a mediator and moderator between adult attachment and depressive mood. *Journal of Counseling Psychology* 51 (2): 201-212.
- Weiss, R.. 1974. The provisions of social relationships. In *Doing unto others*, ed. Z. Rubin, 17-26. Englewood Cliffs, NJ: Prentice Hall.
- Werner, J. S. and M. H. Frost. 2000. *Stress and Coping State of the Science and Implications for Nursing Theory, Research, and Practice*. Glenview, Ill: Midwest Nursing Research Society.
- Wheaton, B.. 1994. Sampling the stress universe. In *Stress and mental health: Contemporary issues and prospects for the future*, ed. W. R. Avison and I. H. Gotlib, 77-114. New York: Plenum Press.
- Wong, S.. 1994. Roaming Yuppies: Hong Kong Migration to Australia. *Asian and Pacific Migration Journal* 3: 373-92.

In Korean

- Hwang, K-S.. 2000. Korean society's changes after IMF crisis. *Theory and Research in Citizenship Education* 30: 355-378.
- Kim, I. 1999. Conditions and alternatives to the disorganization of families in poverty after IMF economic crisis in Korea. *Social Welfare Review* 4: 35-63.
- Korea National Statistical Office. 2006. *Statistical database: Social index in Korea*. Retrieved March 15, 2007 from <<http://www.nso.go.kr>>.
- Shim, S.. 1999. Expansion of nonstandard worker employment and labor welfare. *Industrial and Labor Studies* 5 (2): 149-184.
- Shin, H-K. 1998. Cross-cultural differences in somatization. *Korean Psychological Science* 7 (1): 127-146.
- Yoo, H. J. 2000. Economic crisis and change in social relations. *Korean Journal of Comparative Sociology* 3: 164-205.